

セッティング記録 / SETUP RECORD

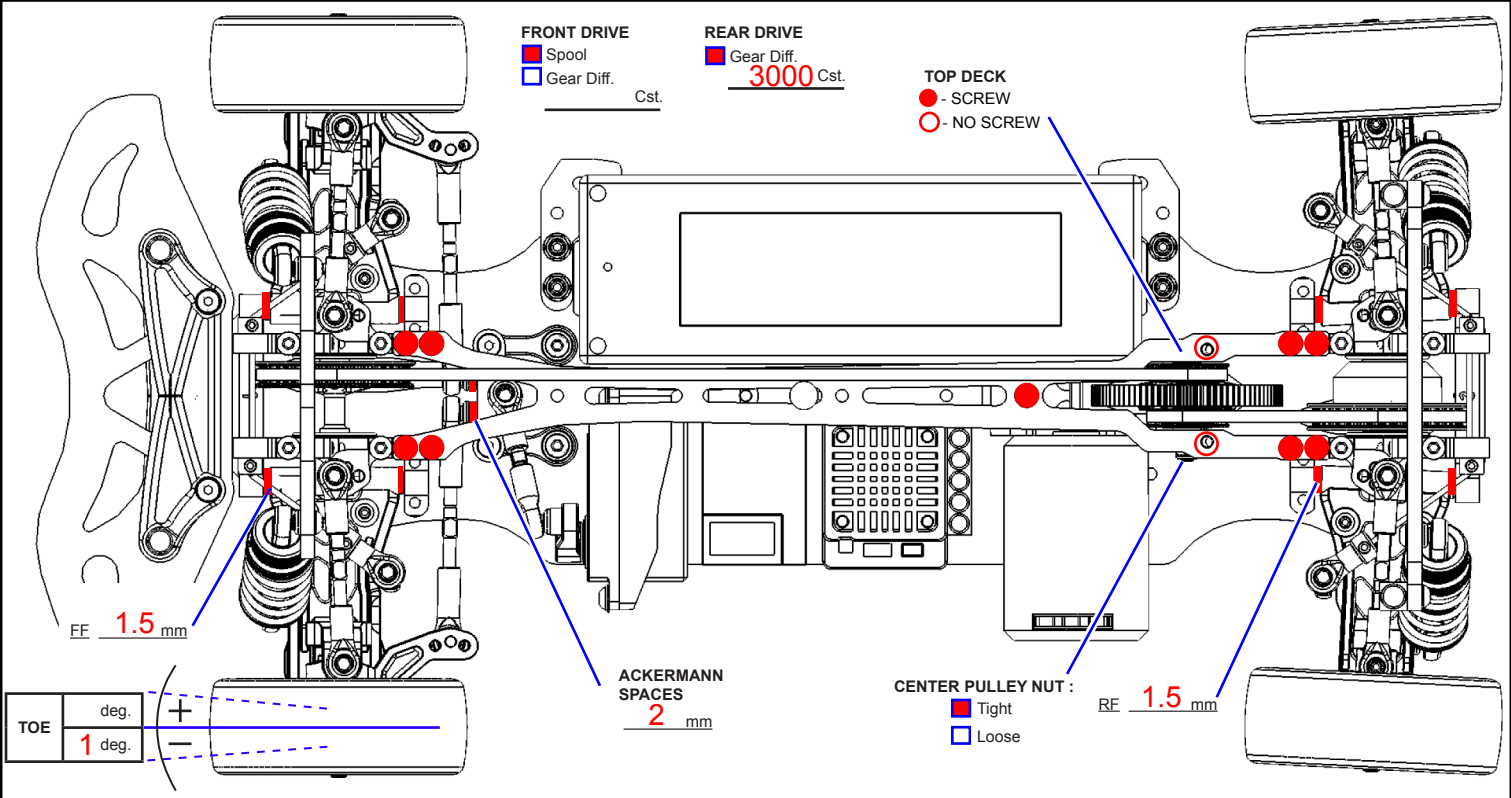

名前: _____ 日付: _____ 트랙: _____
 Name: _____ Date: _____ Track: _____
 国籍: _____ 条件: _____ 温度: _____
 Country: _____ Condition: _____ Temperature: _____



FRONT MEASUREMENTS		FRONT SHOCKS	
RIDE HEIGHT	5 mm	OIL WEIGHT	40 wt /cst
CAMBER ANGLE	1.5 deg	PISTON	<input type="checkbox"/> Opt. <input type="checkbox"/> 1.0mm <input type="checkbox"/> 2hole
ROLL BAR	1.4 mm		<input checked="" type="checkbox"/> Std. <input checked="" type="checkbox"/> 1.2mm <input checked="" type="checkbox"/> 3hole
DOG BONE	std.	BLADDER	std.
NOTES:		SPRING	344
		REBOUND	50 %

REAR MEASUREMENTS		REAR SHOCKS	
RIDE HEIGHT	5.5 mm	OIL WEIGHT	35 wt /cst
CAMBER ANGLE	2 deg	PISTON	<input type="checkbox"/> Opt. <input type="checkbox"/> 1.0mm <input type="checkbox"/> 2hole
ROLL BAR	1.2 mm		<input checked="" type="checkbox"/> Std. <input checked="" type="checkbox"/> 1.2mm <input checked="" type="checkbox"/> 3hole
DOG BONE	std.	BLADDER	std.
NOTES:		SPRING	306
		REBOUND	50 %

MOTOR	
PINION GEAR	
SPUR GEAR	
BATTERY	
BODY SHELLS	
WING	
ESC SETTING	

	FRONT	REAR
BRAND		
COMPOUND		
INSERT		
WHEEL		
TIRE TREATMENT		

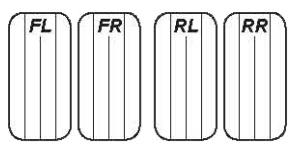

NOTES:

