

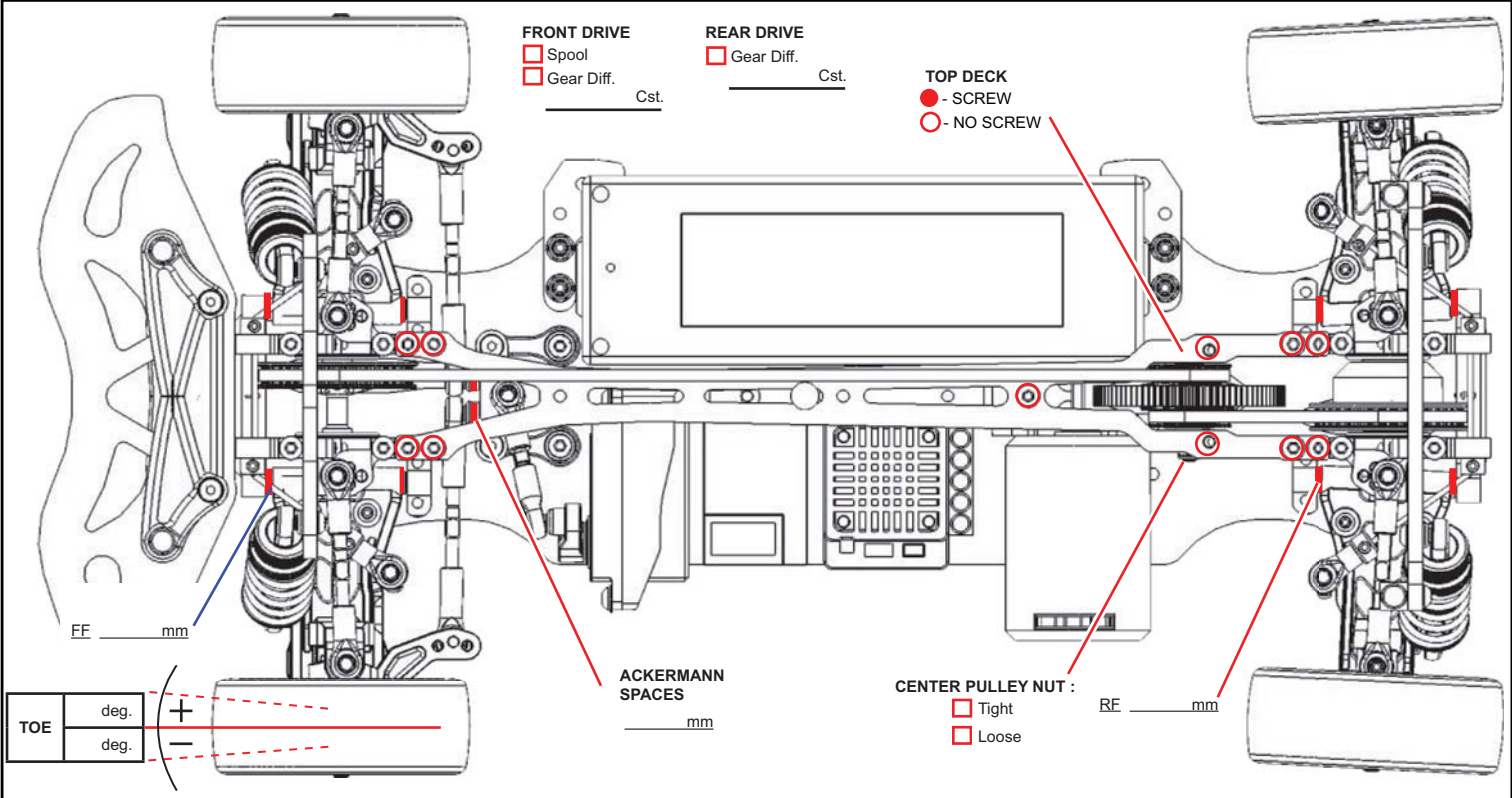

Arn0

Name: _____ Date: _____ Air Temp: _____
 Track: _____ Country: _____ Track Temp: _____
 Track Condition: _____
 Qualify: _____ Main: _____ Finish: _____ Fastest lap: _____



FRONT MEASUREMENTS		FRONT SHOCKS	
RIDE HEIGHT	mm	OIL WEIGHT	wt / cst
CAMBER ANGLE	deg	PISTON	<input type="checkbox"/> Opt. <input type="checkbox"/> 1.0mm <input type="checkbox"/> 2hole
ROLL BAR	mm		<input type="checkbox"/> Std. <input type="checkbox"/> 1.2mm <input type="checkbox"/> 3hole
DOG BONE		BLADDER	
NOTES:		SPRING	
		REBOUND	%

REAR MEASUREMENTS		REAR SHOCKS	
RIDE HEIGHT	mm	OIL WEIGHT	wt / cst
CAMBER ANGLE	deg	PISTON	<input type="checkbox"/> Opt. <input type="checkbox"/> 1.0mm <input type="checkbox"/> 2hole
ROLL BAR	mm		<input type="checkbox"/> Std. <input type="checkbox"/> 1.2mm <input type="checkbox"/> 3hole
DOG BONE		BLADDER	
NOTES:		SPRING	
		REBOUND	%

MOTOR	
PINION GEAR	
SPUR GEAR	
BATTERY	
BODY SHELLS	
WING	
ESC SETTING	

	FRONT	REAR
BRAND		
COMPOUND		
INSERT		
WHEEL		
TIRE TREATMENT		

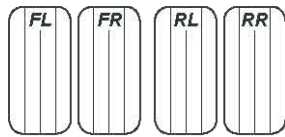

NOTES:

