

セッティング記録 / SETUP RECORD

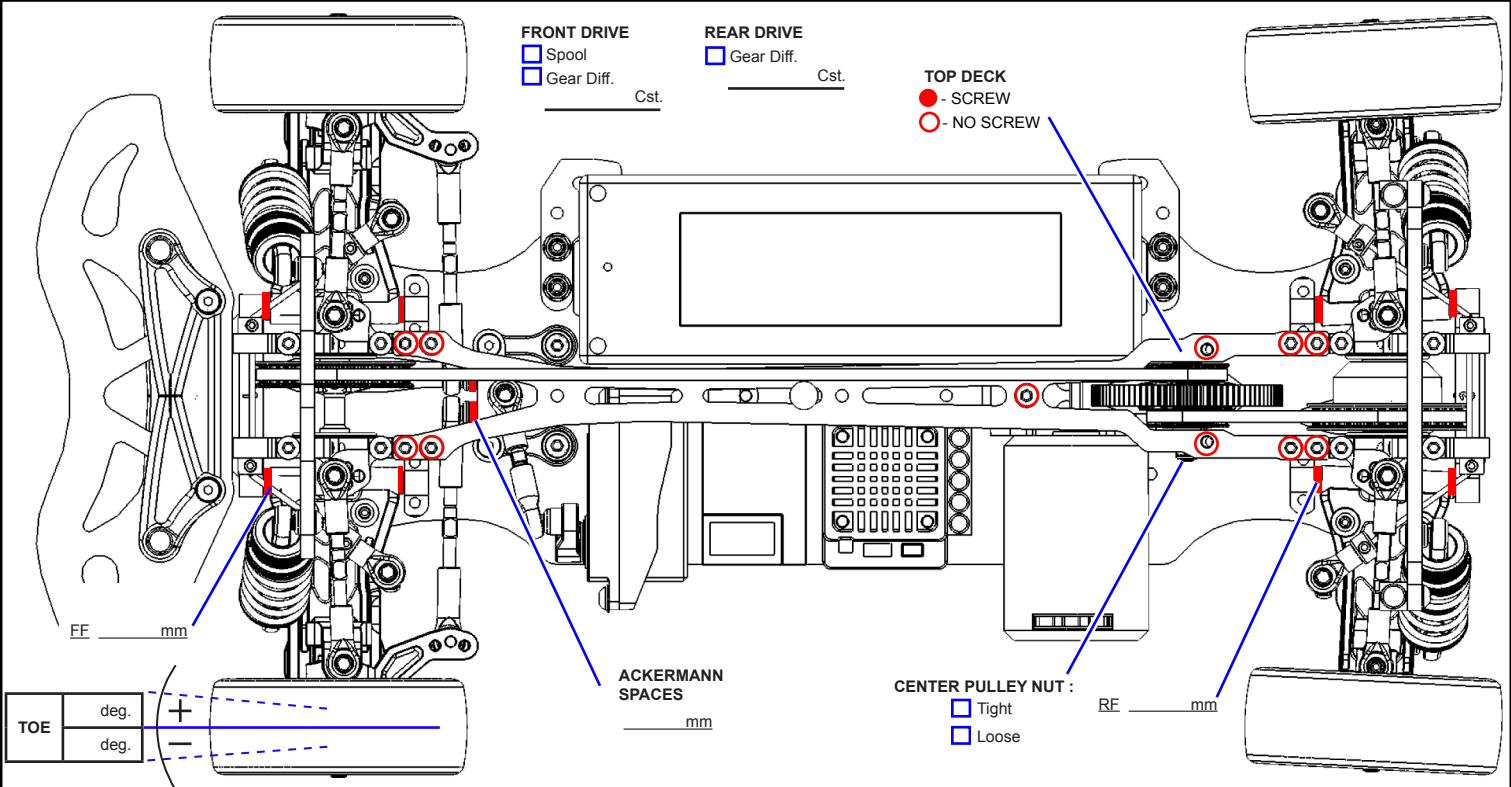

名前: \_\_\_\_\_ 日付: \_\_\_\_\_ トラック: \_\_\_\_\_  
 Name: \_\_\_\_\_ Date: \_\_\_\_\_ Track: \_\_\_\_\_  
 国籍: \_\_\_\_\_ 条件: \_\_\_\_\_ 温度: \_\_\_\_\_  
 Country: \_\_\_\_\_ Condition: \_\_\_\_\_ Temperature: \_\_\_\_\_



FRONT MEASUREMENTS		FRONT SHOCKS	
RIDE HEIGHT	mm	OIL WEIGHT	wt / cst
CAMBER ANGLE	deg	PISTON	<input type="checkbox"/> Opt. <input type="checkbox"/> 1.0mm <input type="checkbox"/> 2hole
ROLL BAR	mm		<input type="checkbox"/> Std. <input type="checkbox"/> 1.2mm <input type="checkbox"/> 3hole
DOG BONE		BLADDER	
NOTES:		SPRING	
		REBOUND	%

REAR MEASUREMENTS		REAR SHOCKS	
RIDE HEIGHT	mm	OIL WEIGHT	wt / cst
CAMBER ANGLE	deg	PISTON	<input type="checkbox"/> Opt. <input type="checkbox"/> 1.0mm <input type="checkbox"/> 2hole
ROLL BAR	mm		<input type="checkbox"/> Std. <input type="checkbox"/> 1.2mm <input type="checkbox"/> 3hole
DOG BONE		BLADDER	
NOTES:		SPRING	
		REBOUND	%

MOTOR	
PINION GEAR	
SPUR GEAR	
BATTERY	
BODY SHELLS	
WING	
ESC SETTING	

	FRONT	REAR
BRAND		
COMPOUND		
INSERT		
WHEEL		
TIRE TREATMENT		

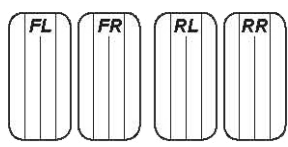

NOTES:

