

セッティング記録 / SETUP RECORD

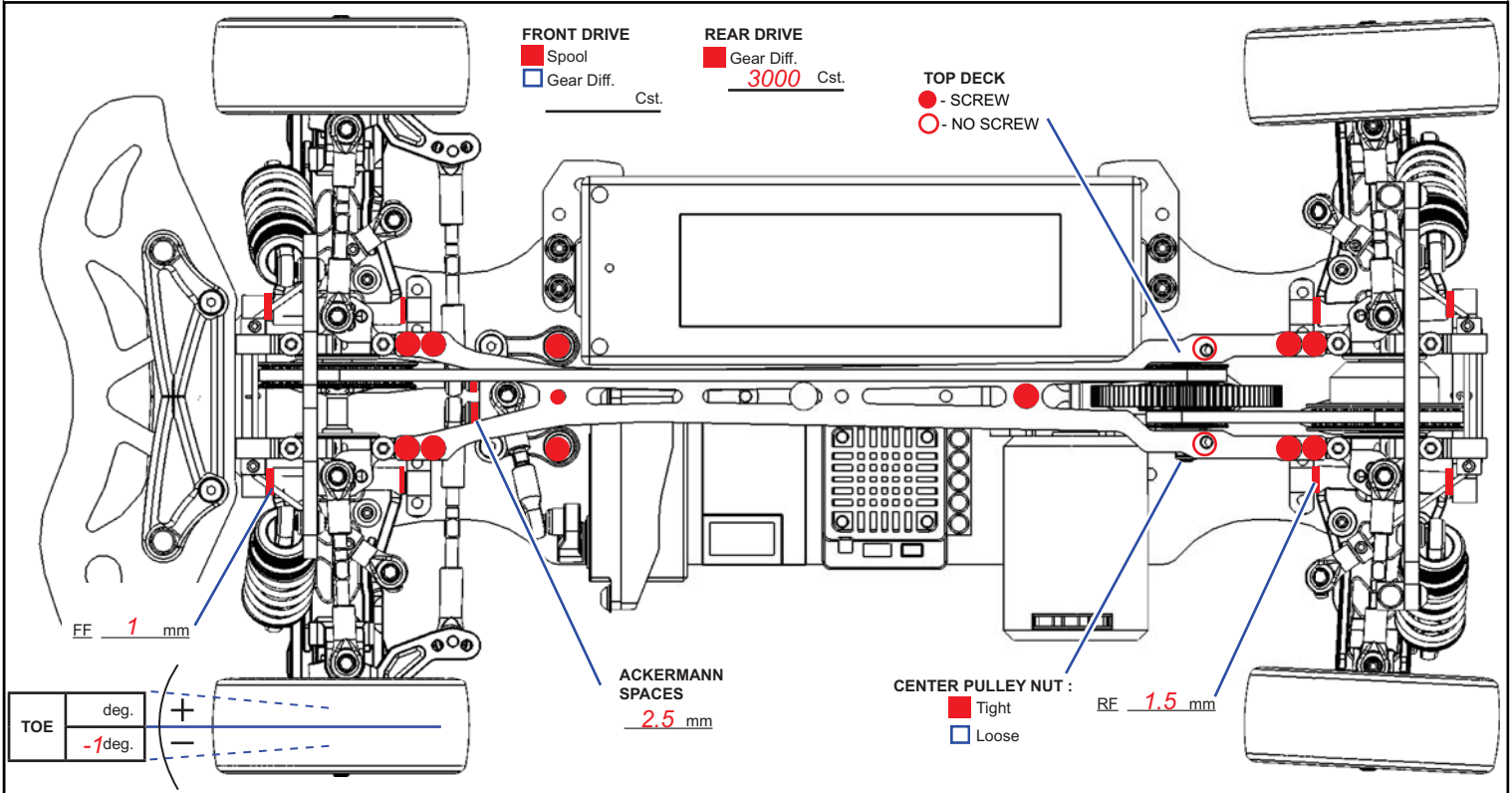

名前: **E.J. Evans** 日付: **Oct 13-18** トラック: **IIC Carpet**
 国籍: **USA** 条件: **High bite** 温度: _____
 Country: **USA** Condition: **High bite** Temperature: _____



FRONT MEASUREMENTS		FRONT SHOCKS	
RIDE HEIGHT	5 mm	OIL WEIGHT	40 wt/ cst
CAMBER ANGLE	0.5 deg	PISTON	■ Opt. □ 1.0mm □ 2hole
ROLL BAR	1.4 mm		□ Std. ■ 1.2mm ■ 3hole
DOG BONE	DCJ	BLADDER	Std.
NOTES:	Using Hudy Setup Station		
		SPRING	YOKOMO PINK
		REBOUND	0 %

REAR MEASUREMENTS		REAR SHOCKS	
RIDE HEIGHT	5.5 mm	OIL WEIGHT	45 wt/ cst
CAMBER ANGLE	2 deg	PISTON	■ Opt. □ 1.0mm □ 2hole
ROLL BAR	1.3 mm		□ Std. ■ 1.2mm ■ 3hole
DOG BONE	44.5	BLADDER	Std.
NOTES:			
		SPRING	YOKOMO BLUE
		REBOUND	0 %

MOTOR	13.5t
PINION GEAR	
SPUR GEAR	
BATTERY	
BODY SHELLS	
WING	
ESC SETTING	

	FRONT	REAR
BRAND		
COMPOUND		
INSERT		
WHEEL		
TIRE TREATMENT		

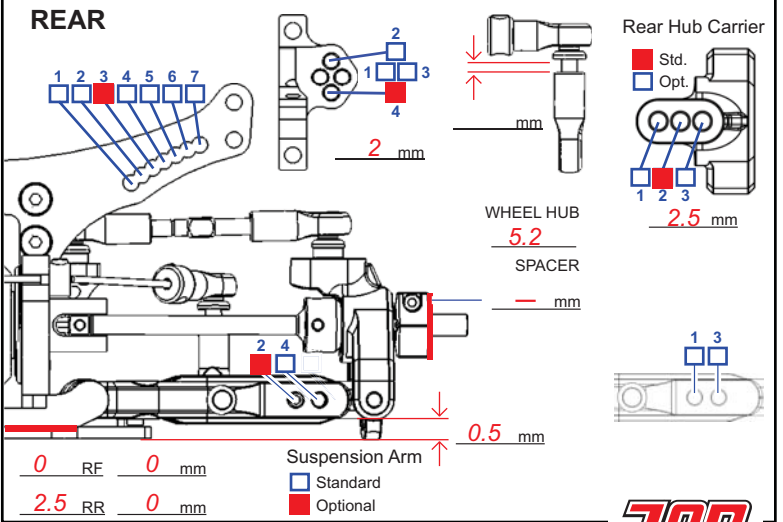
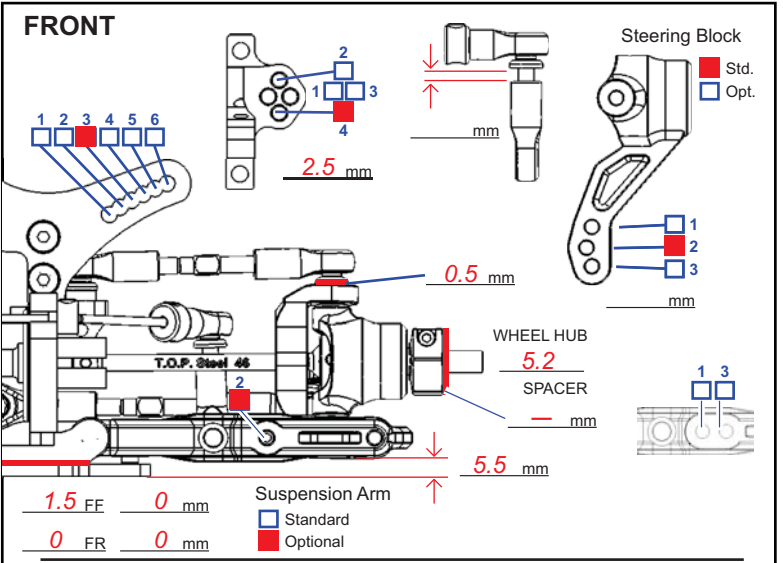
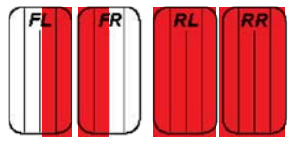

NOTES:
 Steering Post Mount **PO-SCH052RD**

