

# "Scythe"

FXghc F [ XXg`a 4 \_=TcTa

Name **Satoshi Yamazaki** Date **2005.11.06** Humidity **50 %** Air Temp. **10 °C**  
 Track **Kawaba RC Plaza** Track Condition **bad 1 2 3 (4) 5 good** Track Temp. **15 °C**

## Front Suspension

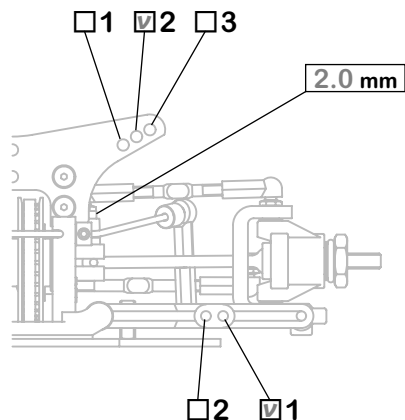

Camber Angle **-1.0 °**  
 Castor **4 °**  
 Ride Height **4.5 mm**  
 Droop **5.0 mm**  
 FR. Drive **1way**  
 Stabilizer Bar  $\phi$  **1.6**  
 Stick out **3.0 mm**  
 Toe Angle **-1 °**  
 Notes

Sus. Mount **F 2.5 R 0** Sus. Mount Spacer **F 0.5 mm R 1.0 mm**

## Rear Suspension

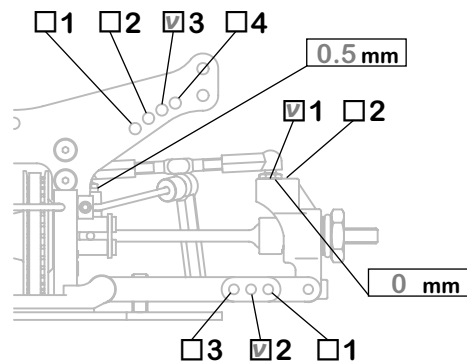

Camber Angle **-1.5 °**  
 Ride Height **4.8 mm**  
 Droop **5.0 mm**  
 Stabilizer Bar  $\phi$  **1.8**  
 Stick out **0 mm**  
 Upright Spacer **F 3 mm R 0 mm**  
 Notes

Sus. Mount **F 0 R 3.0** Sus. Mount Spacer **F 0.5 mm R 1.0 mm**

## Ackermann

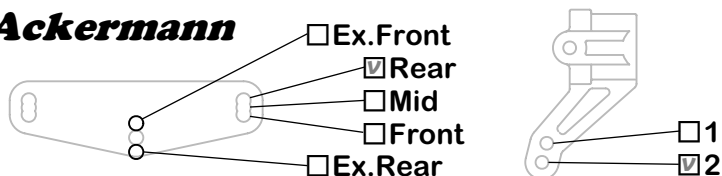

## Radio

Transmitter **KO EX-10 Helios**  
 Receiver **KO KR-302FS**  
 Servo **Hitec HS-5975HB**  
 ESC **KO VFS-1 pro Competition**

## Shock Absorber

	Front	rear
Piston & Holes	Yokomo #3 $\phi$ 0.9 x 3	Yokomo #3 $\phi$ 0.9 x 3
Oil	associ. #30	associ. #25
Spring	OVA $\phi$ 1.4-4.75	OVA $\phi$ 1.4-5.50
Diaphragm	Simizu PS-0903	Simizu PS-0903
Form	—	—
Other		

## Tire

	Front	rear								
Brand	Sorex 32R	Sorex 32R								
Insert	<b>Stealthy Firm</b>	<b>Stealthy Firm</b>								
Wheel	<b>Parabolic Dish</b>	<b>Parabolic Dish</b>								
Additive	Paragon FX- II	Paragon FX- II								
Spreaded Area	<table border="1"> <tr> <td>FL.</td> <td>FR.</td> <td>RL.</td> <td>RR.</td> </tr> <tr> <td></td> <td></td> <td></td> <td></td> </tr> </table>	FL.	FR.	RL.	RR.					
FL.	FR.	RL.	RR.							

## Power Source

Motor	TECTRO EX	Battery	IB3800
Rotor	1145 Mix 9T	<b>Gear Ratio</b>	
Brush	Edge Sprint	Spur	102
Spring	$\phi$ 0.29 9T	Pinion	÷ 30
Timing	9 deg.	2nd Reduction	× 2.200
		Over All Ratio	7.48

## Body

RIDE Accord Ttpe B

## Wing

Yokomo Gokuraku 3.1 R