

標準セッティング記録 / STANDARD SETUP RECORD

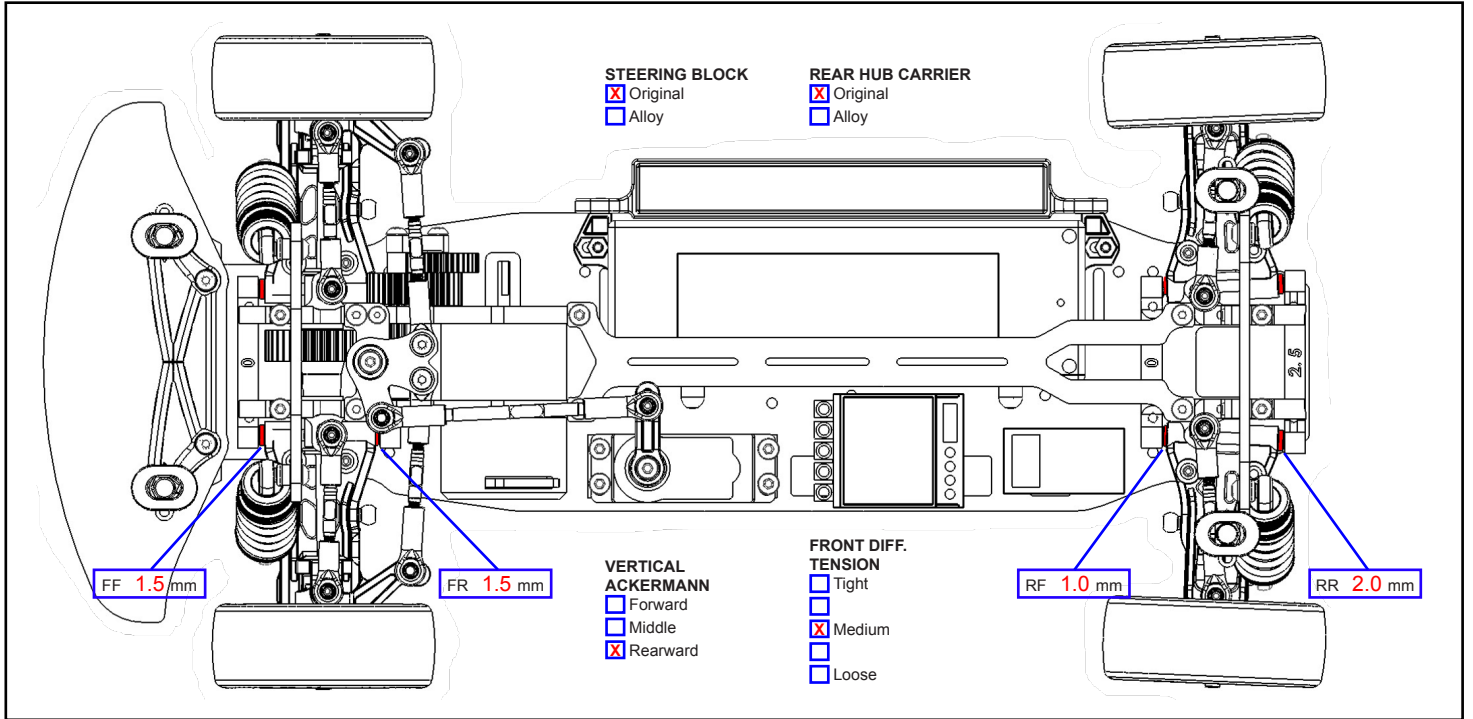

名前: _____ 日付: _____ 트랙: _____
 Name: _____ Date: _____ Track: _____
 国籍: _____ 条件: _____ 温度: _____
 Country: _____ Condition: _____ Temperature: _____



FRONT MEASUREMENTS		FRONT SHOCKS	
RIDE HEIGHT	4.5 mm	OIL WEIGHT	40 wt
CAMBER ANGLE	2.5 deg	PISTON	Standard/ Optional
DOWNSTOP	3.0 mm	BLADDER	STD.
WHEEL HUBS	STD 5.2 mm	SPRING	344g
WHEEL SPACER	0.0 mm	PISTON HOLE	1.0mm/ 1.2mm ; 2/3 hole

REAR MEASUREMENTS		REAR SHOCKS	
RIDE HEIGHT	5.0 mm	OIL WEIGHT	40 wt
CAMBER ANGLE	2.5 deg	PISTON	Standard/ Optional
DOWNSTOP	4.5 mm	BLADDER	STD.
WHEEL HUBS	STD 5.2 mm	SPRING	306g
WHEEL SPACER	0.0 mm	PISTON HOLE	1.0mm/ 1.2mm ; 2/3 hole

MOTOR	10.5 BL
PINION GEAR	04-18T
BATTERY	7.4V LiPo
BODY SHELLS	SP FD2
WING	Optional.
ESC SETTING	LRP Stock Spec.: Mode 2 - 4 Mode 3 - 8
NOTES:	

	FRONT	REAR
BRAND	Solaris	Solaris
COMPOUND	M	M
INSERT	GR-M	GR-M
WHEEL	Solaris	Solaris
TIRE TREATMENT	FX-II	FX-II

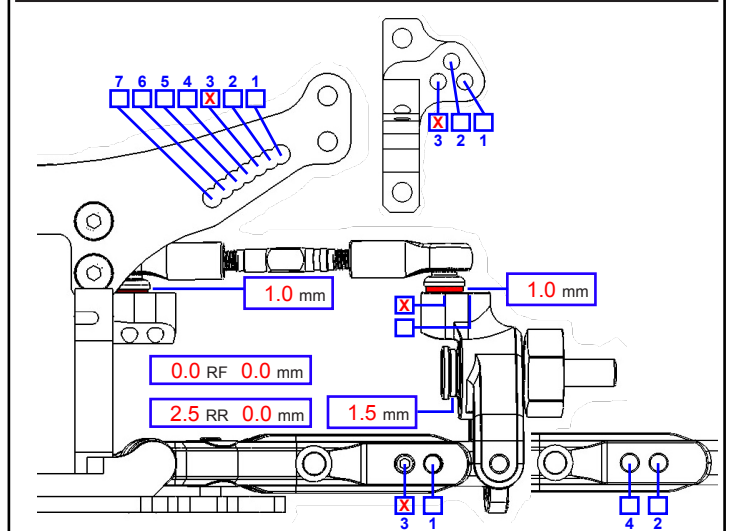
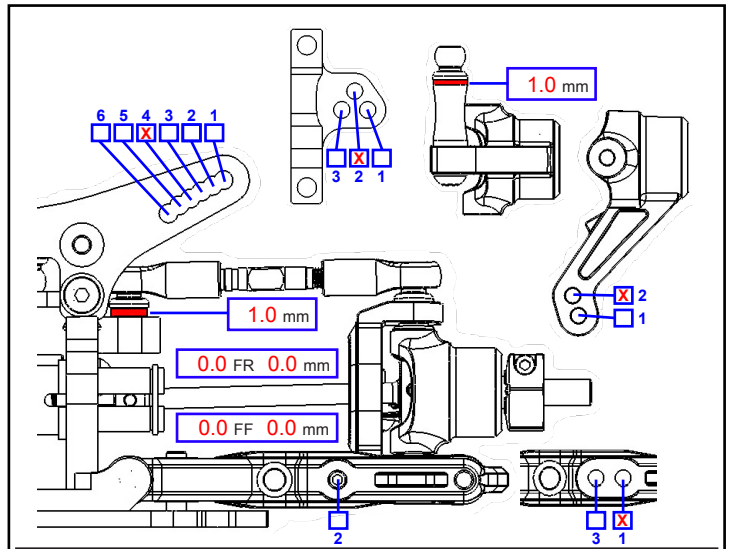

NOTES: