

セッティング記録 / SETUP RECORD



名前: _____
 Name: _____
 国籍: _____
 Country: _____

日付: _____
 Date: _____
 条件: _____
 Condition: _____

トラック: _____
 Track: _____
 温度: _____
 Temperature: _____

FRONT DRIVE Spool Gear Diff. Ball Diff. One-Way Note: _____

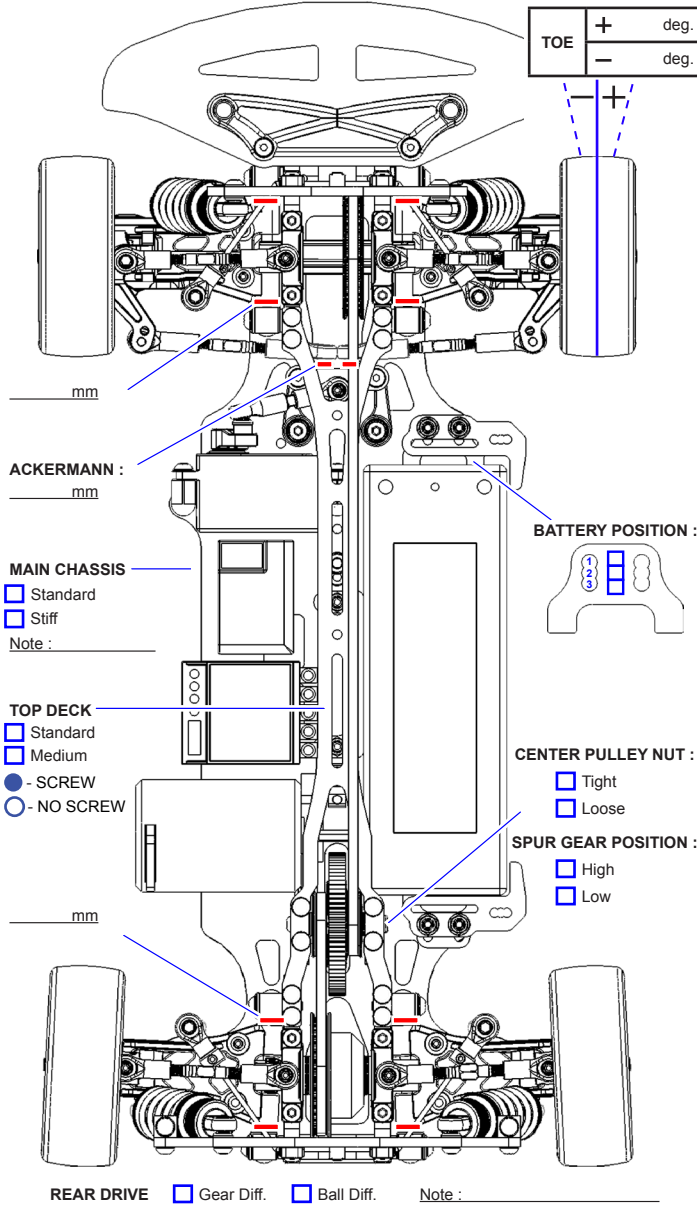

FRONT MEASUREMENTS

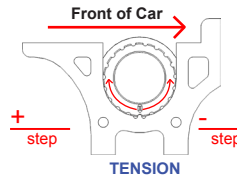

FRONT SHOCKS

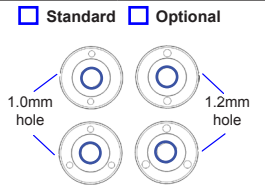

RIDE HEIGHT	mm	OIL WEIGHT	wt
CAMBER ANGLE	deg	BLADDER	
DOG BONE	mm	SPRING	
WHEEL HUBS	mm	NOTE	
WHEEL SPACER	mm		

REAR MEASUREMENTS

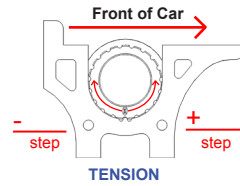

REAR SHOCKS

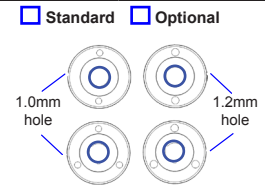

RIDE HEIGHT	mm	OIL WEIGHT	wt
CAMBER ANGLE	deg	BLADDER	
DOG BONE	mm	SPRING	
WHEEL HUBS	mm	NOTE	
WHEEL SPACER	mm		

MOTOR		FRONT	REAR
SPUR GEAR	BRAND		
PINION GEAR	COMPOUND		
BATTERY	INSERT		
BODY SHELLS	WHEEL		
WING	TIRE TREATMENT		
ESC SETTING		FL	FR
		RL	RR

FRONT

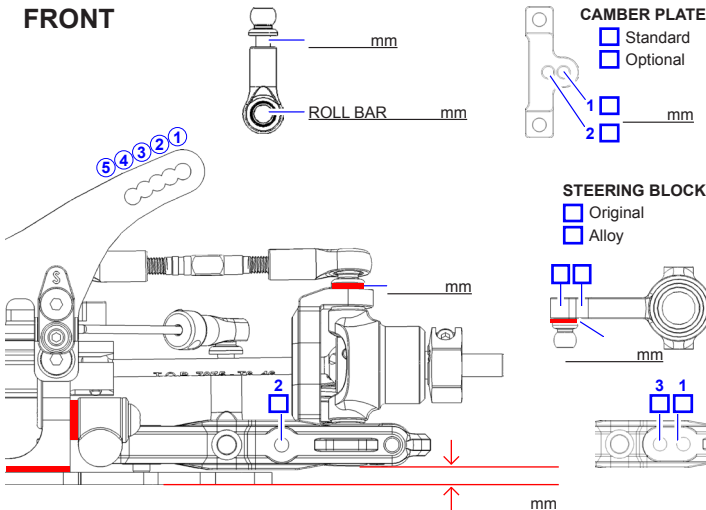

Roll Ctr. Shim : FF _____ mm / FR _____ mm
 Toe-Out : (FF _____ mm - FR _____ mm) / 0.8 = _____ deg

REAR

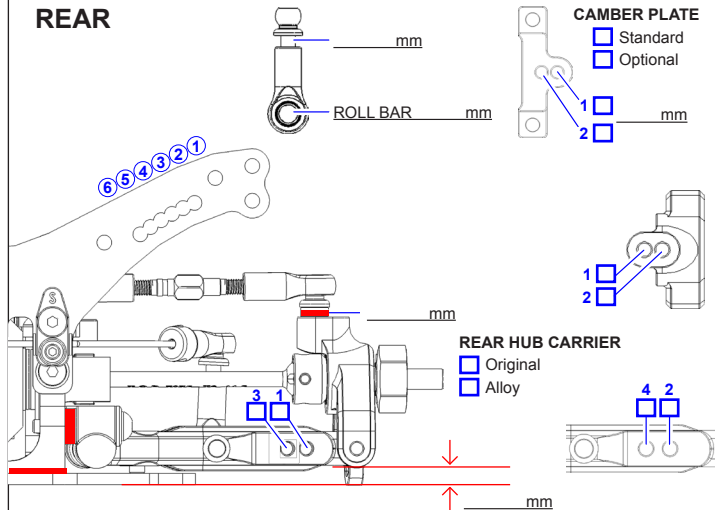

Roll Ctr. Shim : RR _____ mm / RF _____ mm
 Toe-In : (RR _____ mm - RF _____ mm) / 0.8 = _____ deg