

# セッティング記録 / SETUP RECORD

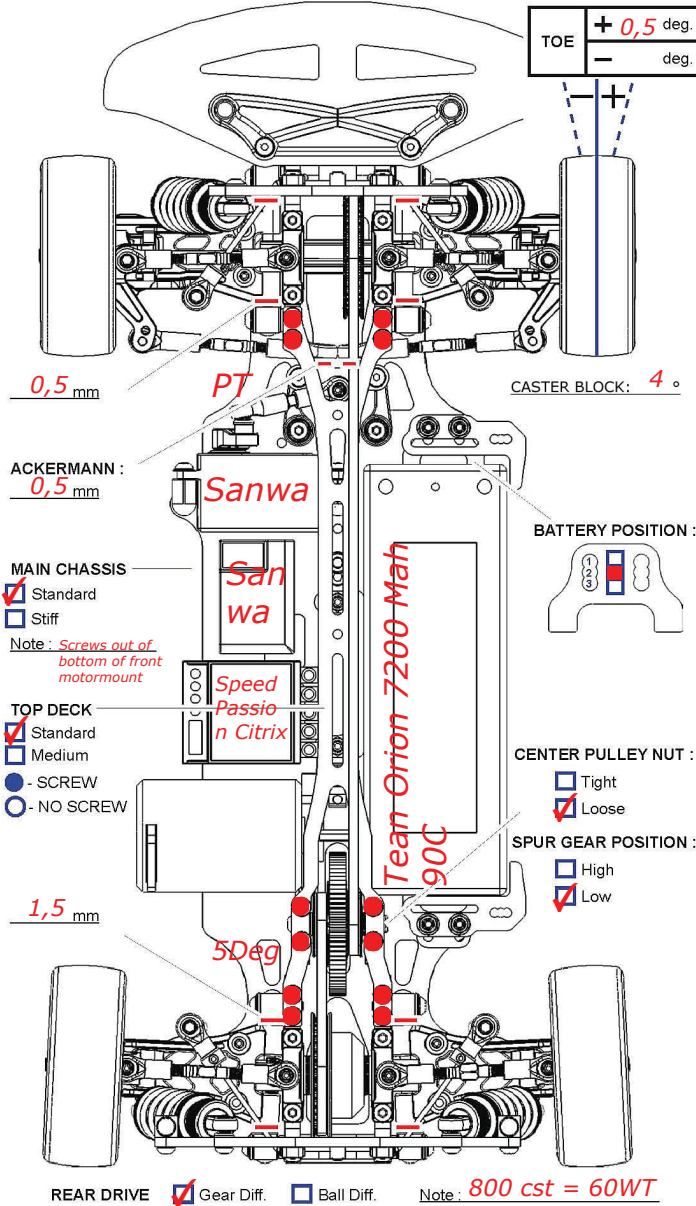

Name: Robert Krens Date: 19-05-2013 Air Temp: 18degC  
 Track: AMCA Apeldoorn Country: Netherlands Track Temp: 12degC  
 Track Condition: Cold track, no dust, no stones, really good grip when temp comes up.  
 Qualify: 18th Main: B Finish: 17th Fastest lap: 17,635. 17R 5:06

FRONT DRIVE  Spool  Gear Diff.  Ball Diff.  One-Way Note: plastic cups



## FRONT MEASUREMENTS

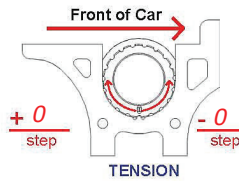

## FRONT SHOCKS

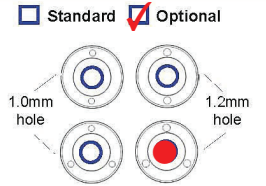

RIDE HEIGHT	<u>5.0 mm</u>	OIL WEIGHT	<u>425CST = 35 wt</u>
CAMBER ANGLE	<u>2 deg</u>	BLADDER	<u>Black std</u>
DOG BONE	<u>46 mm</u>	SPRING	<u>Zilver 16,9LBS</u>
WHEEL HUBS	<u>5 mm</u>	NOTE	<u>Hole in shock cap. 0% Rebound</u>
WHEEL SPACER	<u>0 mm</u>		

## REAR MEASUREMENTS

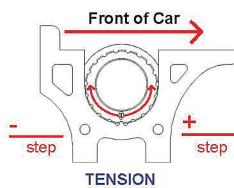

## REAR SHOCKS

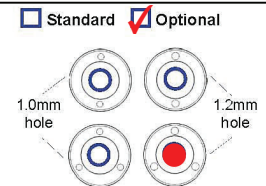

RIDE HEIGHT	<u>5.3 mm</u>	OIL WEIGHT	<u>425CST = 35 wt</u>
CAMBER ANGLE	<u>1,5 deg</u>	BLADDER	<u>Black std</u>
DOG BONE	<u>44,5 mm</u>	SPRING	<u>Zilver 16,9LBS</u>
WHEEL HUBS	<u>5 mm</u>	NOTE	<u>Hole in shock cap. 0% Rebound</u>
WHEEL SPACER	<u>0 mm</u>		

MOTOR	<u>Speed Passion 13,5T V3 (Hand out)</u>	FRONT	REAR
SPUR GEAR	<u>98</u>	BRAND	<u>Ride Rex 34 (Hand out)</u>
PINION GEAR	<u>49</u>	COMPOUND	<u>Tire warmers 60/70 degC</u>
BATTERY	<u>Team Orion 7200 Mah</u>	INSERT	<u>Keep warmers on till grid</u>
BODY SHELLS	<u>Speed 6</u>	WHEEL	<u>Keep tires wet when warm</u>
WING	<u>JG-Racing Wide wing. 10mm over</u>	TIRE TREATMENT	<u>MR33 + special 1/4</u>
ESC SETTING			

## FRONT

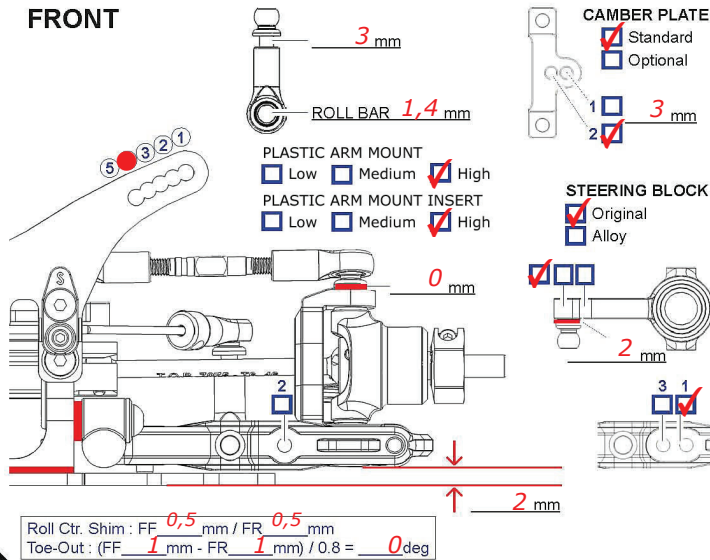

## REAR

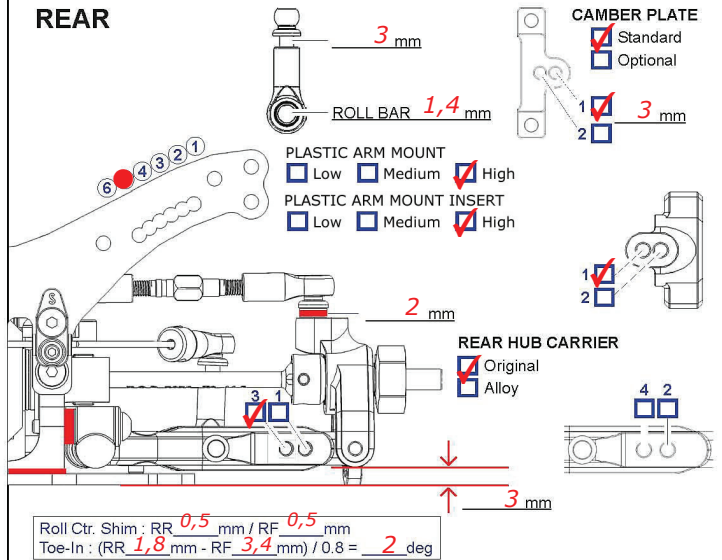

Droop above ride height. Aluminium driveshaft's all around. Weight: 1400gr. Switched from 1,75 deg rear toe, to 2 deg rear toe to get a bit more forward grip out of the corner, due to the low temperature. Tire treatment: as long as possible, at least 30 min. Keep tires wet when warming them. Two step warming is the best for tires. first 40deg, then 60 deg, over one hour. Car feels really good, but did push a bit on the other set of tires. On new tires it's a bit tail happy coming out of the corner, but that's just for a few laps. Dual fan on motor.

Editable by Arn0 at PetitRC.com

