

セッティング記録 / SETUP RECORD



名前: **EJ Evans**

日付: **May 2013**

トラック: **Reedy**

国籍: **USA**

条件: **Asphalt**

温度: _____

FRONT DRIVE Spool Gear Diff. Ball Diff. One-Way Note: _____

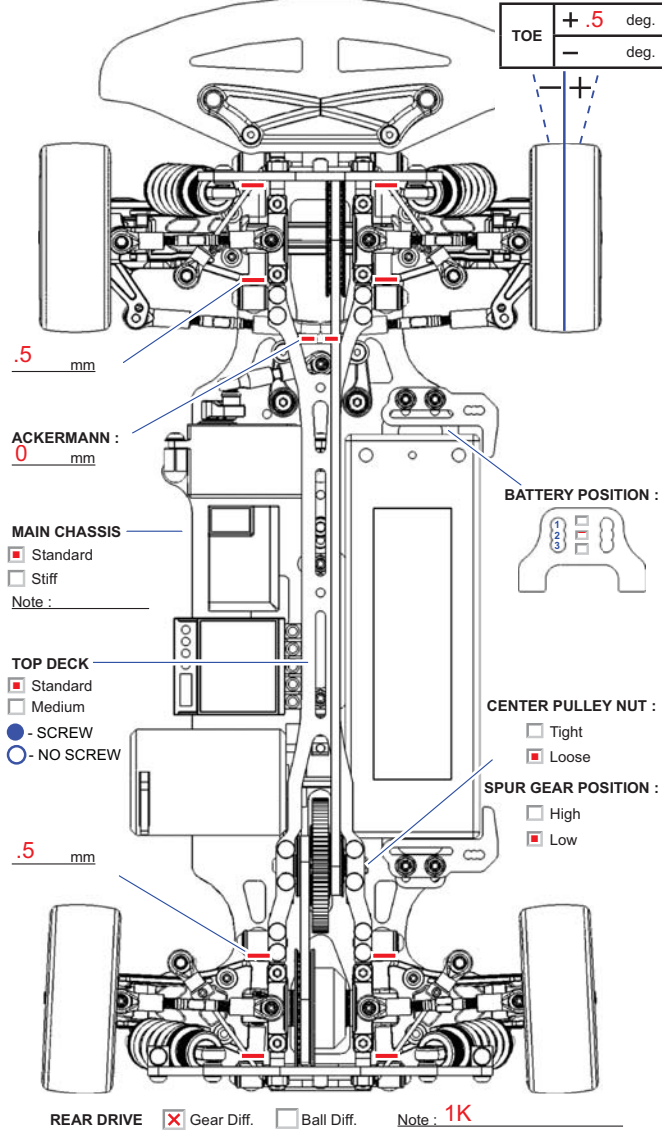

FRONT MEASUREMENTS

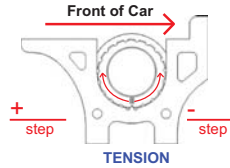

FRONT SHOCKS

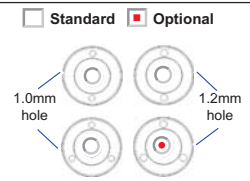

RIDE HEIGHT	5	mm	OIL WEIGHT	50 Assc	wt / cst
CAMBER ANGLE	-1.5	deg	BLADDER	STD	
DOG BONE	DCJ	mm	SPRING	367gf	
WHEEL HUBS	STD	mm	NOTE	Hole in shock car	
WHEEL SPACER	0	mm			

REAR MEASUREMENTS

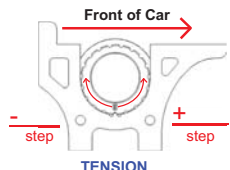

REAR SHOCKS

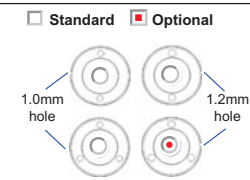

RIDE HEIGHT	5.2	mm	OIL WEIGHT	40 Assc	wt / cst
CAMBER ANGLE	-1.5	deg	BLADDER	STD	
DOG BONE	44.5 Steel	mm	SPRING	306gf	
WHEEL HUBS	STD	mm	NOTE	Hole in shock car	
WHEEL SPACER	.5	mm			

MOTOR		FRONT	REAR
SPUR GEAR	BRAND		
PINION GEAR	COMPOUND		
BATTERY	INSERT		
BODY SHELLS	WHEEL		
WING	TIRE TREATMENT		
ESC SETTING			

FRONT

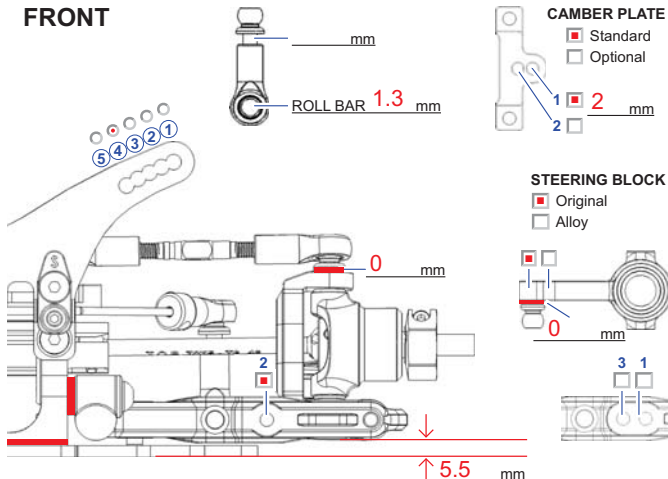

REAR

