

セッティング記録 / SETUP RECORD

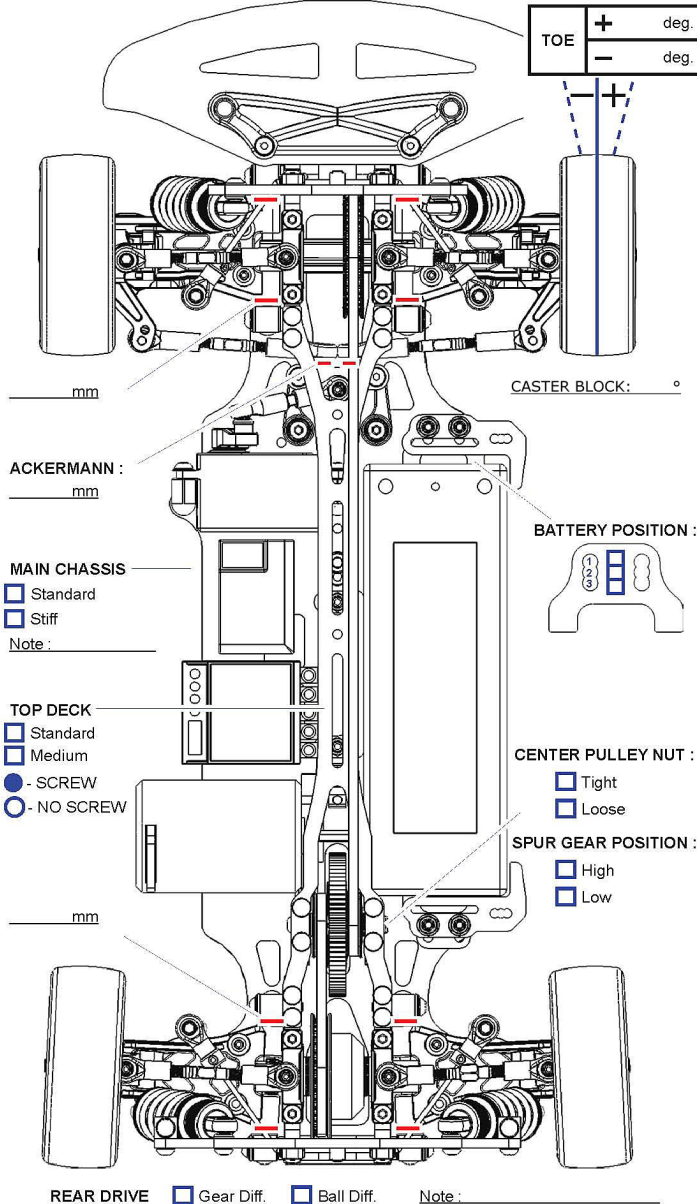

Name: _____ Date: _____ Air Temp: _____
 Track: _____ Country: _____ Track Temp: _____
 Track Condition: _____
 Qualify: _____ Main: _____ Finish: _____ Fastest lap: _____

FRONT DRIVE Spool Gear Diff. Ball Diff. One-Way Note: _____



FRONT MEASUREMENTS

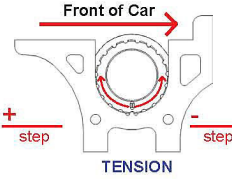

FRONT SHOCKS

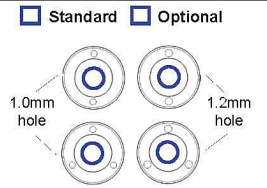

RIDE HEIGHT	mm	OIL WEIGHT	wt
CAMBER ANGLE	deg	BLADDER	
DOG BONE	mm	SPRING	
WHEEL HUBS	mm	NOTE	
WHEEL SPACER	mm		

REAR MEASUREMENTS

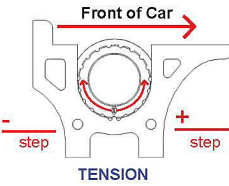

REAR SHOCKS

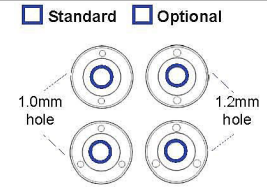

RIDE HEIGHT	mm	OIL WEIGHT	wt
CAMBER ANGLE	deg	BLADDER	
DOG BONE	mm	SPRING	
WHEEL HUBS	mm	NOTE	
WHEEL SPACER	mm		

MOTOR			FRONT	REAR
SPUR GEAR		BRAND		
PINION GEAR		COMPOUND		
BATTERY		INSERT		
BODY SHELLS		WHEEL		
WING		TIRE TREATMENT		
ESC SETTING				

FL

FR

RL

RR

FRONT

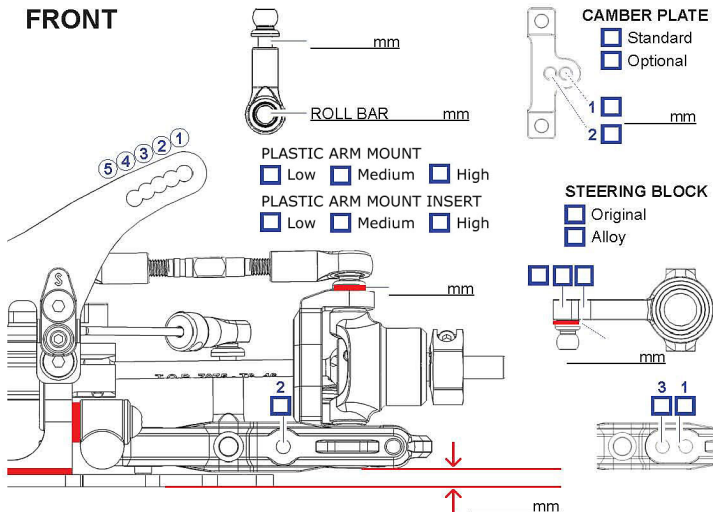

Roll Ctr. Shim: FF _____ mm / FR _____ mm
 Toe-Out: (FF _____ mm - FR _____ mm) / 0.8 = _____ deg

REAR

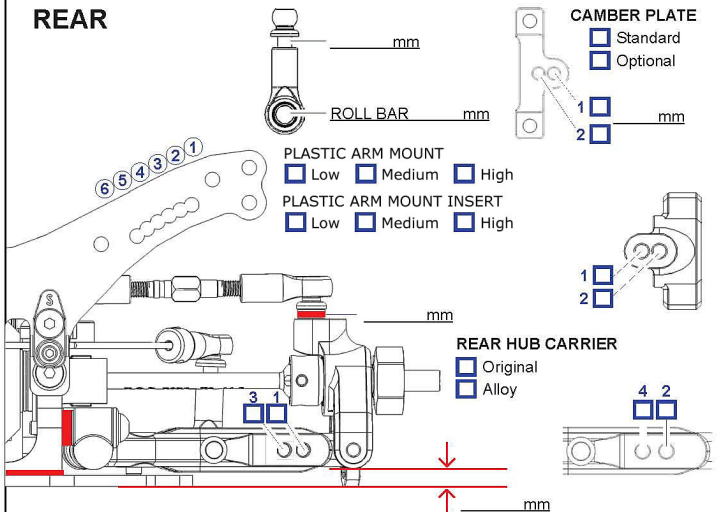

Roll Ctr. Shim: RR _____ mm / RF _____ mm
 Toe-In: (RR _____ mm - RF _____ mm) / 0.8 = _____ deg