

SETUP SHEET



TRACK CONDITIONS

Type :	<input type="checkbox"/> Carpet	<input type="checkbox"/> Asphalt	Size:	<input type="checkbox"/> Open	<input type="checkbox"/> Med.	<input type="checkbox"/> Tight
Place :	<input type="checkbox"/> Indoor	<input type="checkbox"/> Outdoor	Traction:	<input type="checkbox"/> High	<input type="checkbox"/> Med.	<input type="checkbox"/> Low
Surface:	<input type="checkbox"/> Smooth	<input type="checkbox"/> Med.	<input type="checkbox"/> Bumpy	Track Temp/Air Temp: _____ / _____		Note: _____

FRONT SUSPENSION

Track Width: _____ mm Gear Diff _____ wt

Toe Angle: _____ ° Ball Diff

Caster: _____ ° One Way

Camber: _____ ° Solid Axle

Ride Height: _____ mm Anti-Roll Bar: ∅ _____ mm

Down Stop: _____ mm

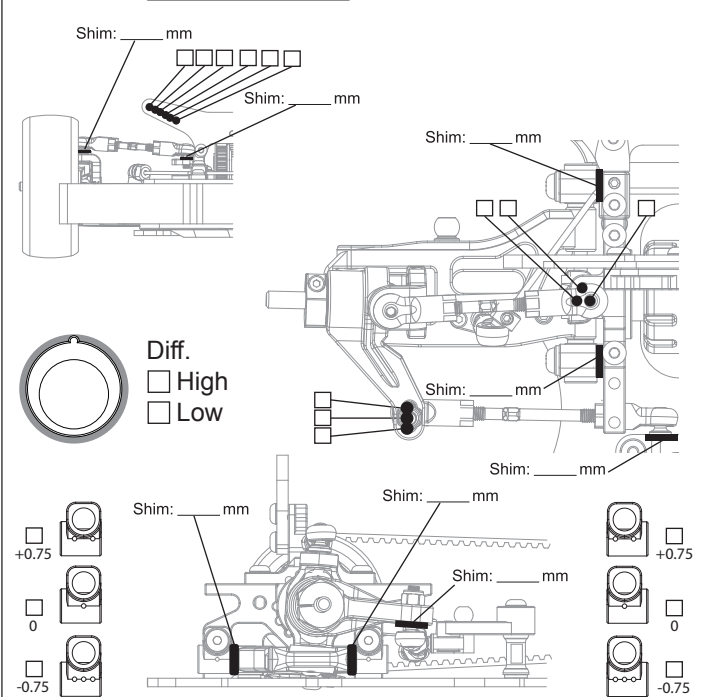

REAR SUSPENSION

Track Width: _____ mm Gear Diff _____ wt

Toe Angle: _____ ° Ball Diff

Camber: _____ ° Solid Axle

Ride Height: _____ mm

Down Stop: _____ mm Anti-Roll Bar: ∅ _____ mm

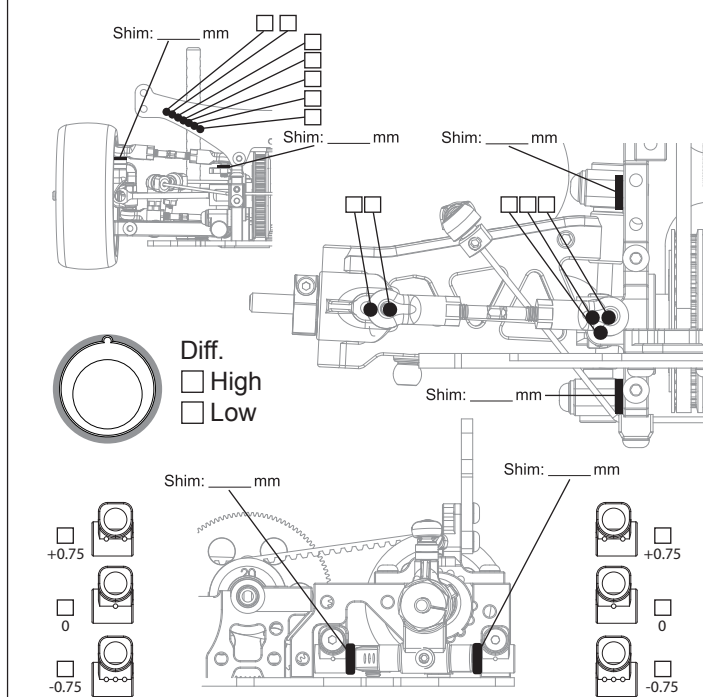

STIFF SETTING



ELECTRONICS

Servo: _____

ESC: _____

Battery: _____

DRIVE RATIO

Spur $\frac{T}{T} \times 1.9 =$ _____

Pinion _____

MOTOR

Brand: _____

Turns: _____

Timing: _____

TIRES

Insert: _____

Wheel: _____

Shore/deg: _____

Compound: _____

Tire Temp: _____

Tire additive: _____

Treated Area

ESC

Punch: _____

Initial Brake: _____

Drag Brake: _____

ESC Timing Turbo Timing

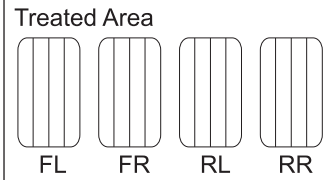

SHOCKS

Hole Size: F _____ R _____

Holes In Piston: F _____ R _____

Oil wt: F _____ R _____

Springs: F _____ R _____

Rebound: F _____ R _____

Bladder Note: _____

Thread Length: F _____ R _____

BODY

Body: _____

Wing Height: _____

Wing Position: _____