

TRACK CONDITIONS

Type : Carpet Asphalt Size: Open Med. Tight
 Place : Indoor Outdoor Traction: High Med. Low
 Surface: Smooth Med. Bumpy Track Temp/Air Temp: _____ / _____
 Note: Front tires side glued

FRONT SUSPENSION

Track Width: +0.8 mm Gear Diff _____ wt
 Toe Angle: +0.5 ° Solid Axle (Spool)
 Caster: 4 ° One Way
 Camber: -1.25 °
 Ride Height: 5.2 mm Anti-Roll Bar: \varnothing 1.3 mm
 Down Stop: 35 mm

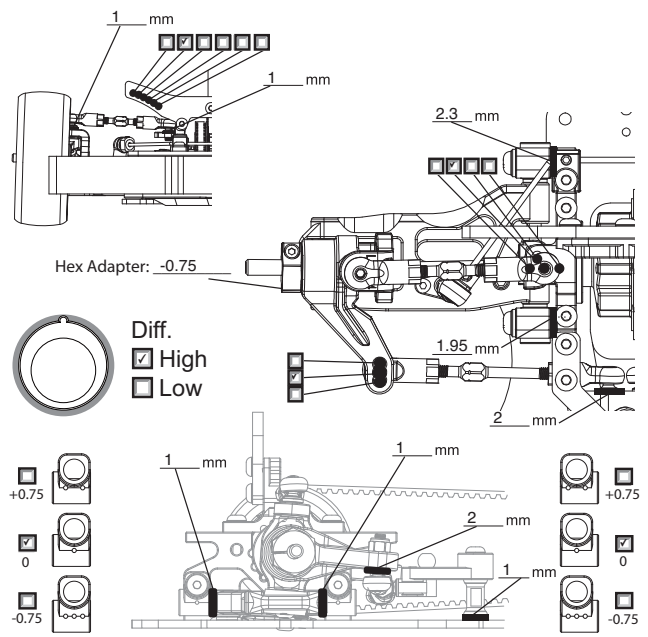

REAR SUSPENSION

Track Width: +0.8 (-0.75 hub) mm Gear Diff Yokomo Dot 4 wt
 Toe Angle: +2.5 °
 Camber: -2.25 °
 Ride Height: 5.2 mm
 Down Stop: 36 mm Anti-Roll Bar: \varnothing 1.2 mm

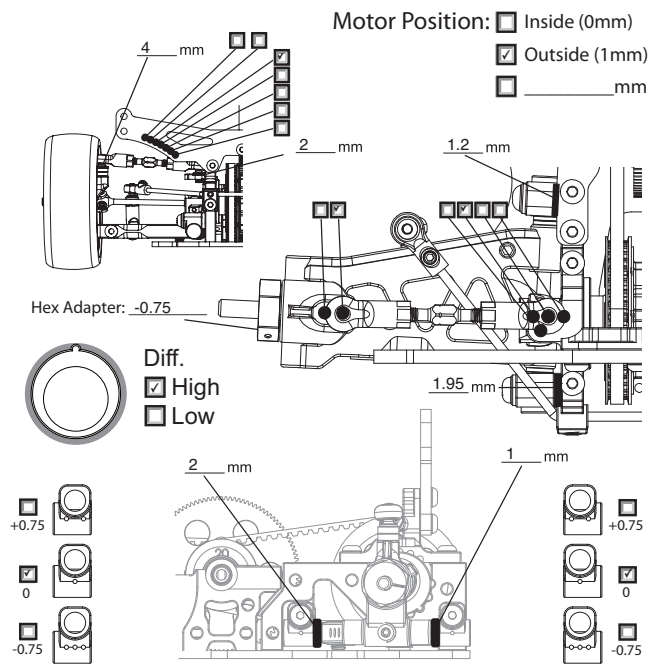

STIFF SETTING

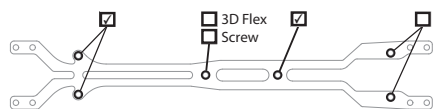

Upper Deck: 2.0mm 2.3mm 2.5mm



Chassis: 2.3mm 2.5mm 3.0mm

ELECTRONICS

Servo: Sanwa BLS V1
 ESC: HW 3.1 PRT
 Battery: Orion 6400 90c

DRIVE RATIO

Spur 108 T
 Pinion 34 T $\times 1.9 =$ 6.04

TIRES

Insert : Rex 30 (Green)
 Wheel: Rex 30 (Green)
 Shore/deg: Rex 30 (Green)
 Compound: Rex 30 (Green)
 Tire Temp: _____
 Tire additive: SITCC
 Treated Area

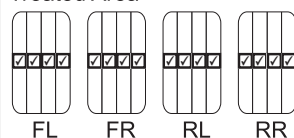

SHOCKS



Hole Size: F stock R stock
 Holes In Piston: F 3 R 3
 Oil wt: F 450 R 450
 Springs: F Ride Purple R Ride Silver
 Rebound: F 0 R 0
 Bladder Note: _____
 Thread Length: F 12 R

MOTOR

Brand: Orion VST 2 Pro
 Turns: 13.5
 Timing: 0

ESC

Punch: _____
 Initial Brake: Drag
 Drag Brake: 0
 ESC Timing Turbo Timing
 FULL

BODY

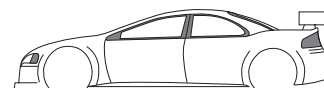

Body: Mazda Speed 6
 Wing Height: max
 Wing Position: max