

# TRF415 SETTING SHEET

## セッティングシート

Name **Eirik Andreassen** Date **18-19.2.2005** Air temp. \_\_\_\_\_ Humidity \_\_\_\_\_  
 Track **Nordic Winter Race** Track condition **Carpet** Track temp. \_\_\_\_\_

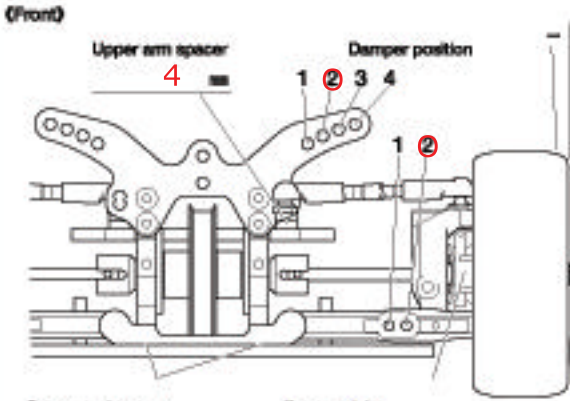

Camber angle	1.5 °
Ground clearance	5.0 mm
Rebound stroke	mm
Front drive	One-way Diff
Stabilizer	S M H
Wheel spacer	0 mm



Urethane bushing	-	Piece(s)
3mm O-ring (black)	-	Piece(s)
3mm O-ring (transparent)	-	Piece(s)
Piston	3	hole(s)
Oil	60	#
Spring	White	

Sus. mount spacer  
 F 0 mm R 0 mm  
 Front upright  
 L C1 C2 R C2 C1

Memo **Drop: 5.5mm**

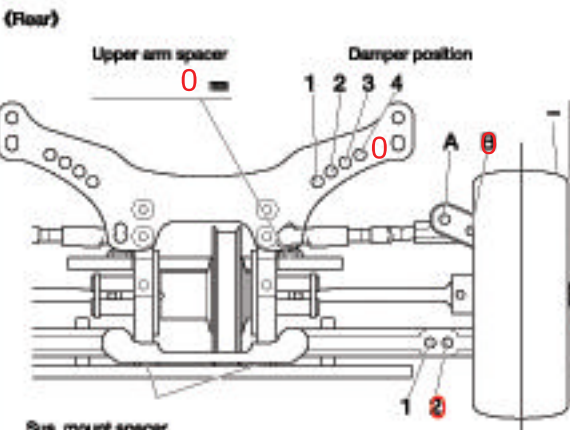

Camber angle	2.0 °
Ground clearance	5.5 mm
Rebound stroke	mm
Stabilizer	S M H
Wheel spacer	0.5 mm



Urethane bushing	-	Piece(s)
3mm O-ring (black)	-	Piece(s)
3mm O-ring (transparent)	-	Piece(s)
Piston	3	hole(s)
Oil	55	#
Spring	Blue	

Sus. mount spacer  
 F 0 mm R 0 mm  
 Rear upright  
 1' 2'

Memo **Drop: 5.0mm**

Toe angle (front) 0 °  
 F sus. mount Front X A B C D Rear A  
 R sus. mount Front X A B C D Rear X A B C D

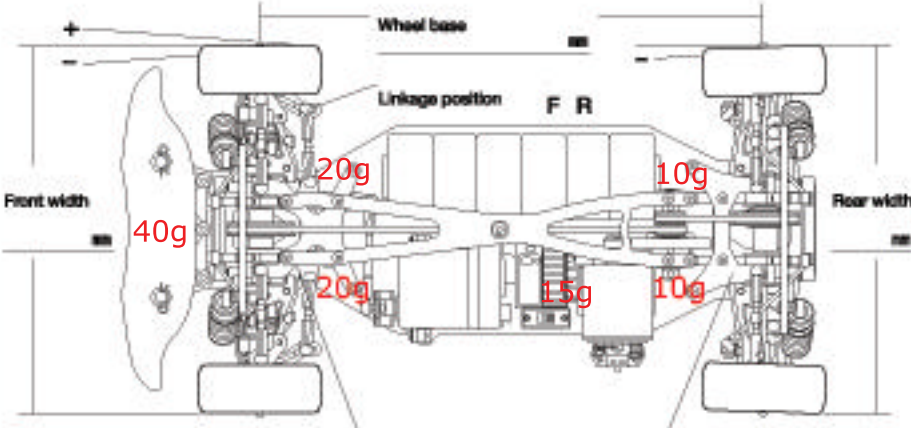

Lower deck 3 mm F sus. arm spacer 2 mm R sus. arm spacer 2 mm

Memo **Alu rear hubs - 1.0mm washer under ball**

Motor **Peak Spash. 12x1**

Spur gear 102 T Pinion gear 28 T

Battery **Peak GP3300**

Body **PF Mazda 6**

Wing **stock**

Tire **Sorex 28R**

Wheel **Orion Hard**

Tire insert **JB Medium**

Best lap **14.37**