

Camber right 1,8°

Camber left 1,8°

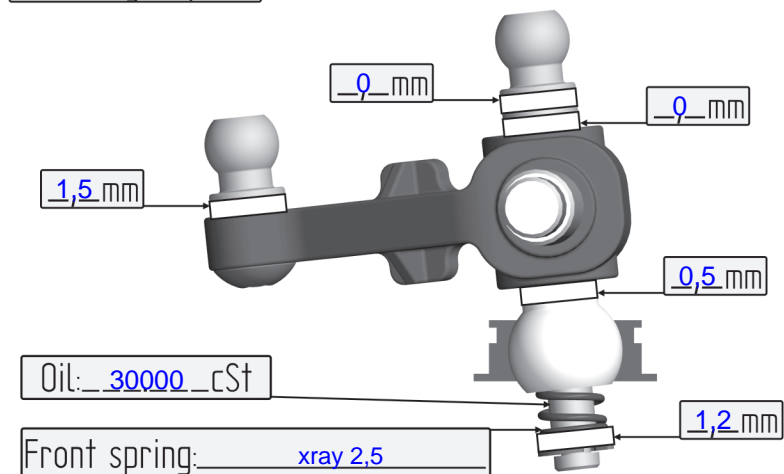
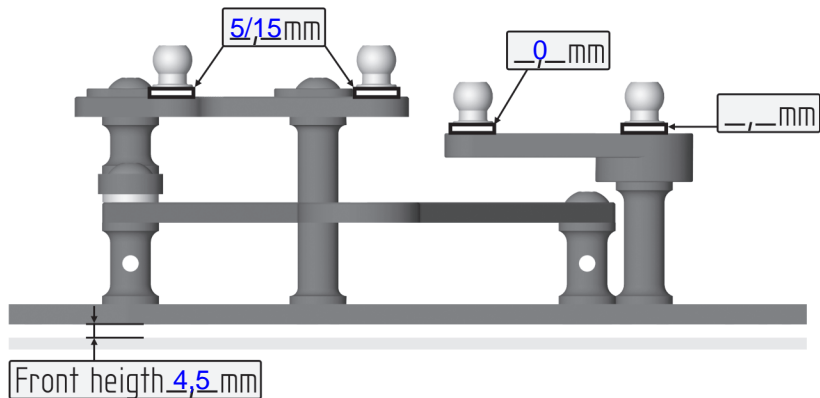
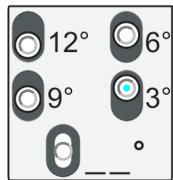
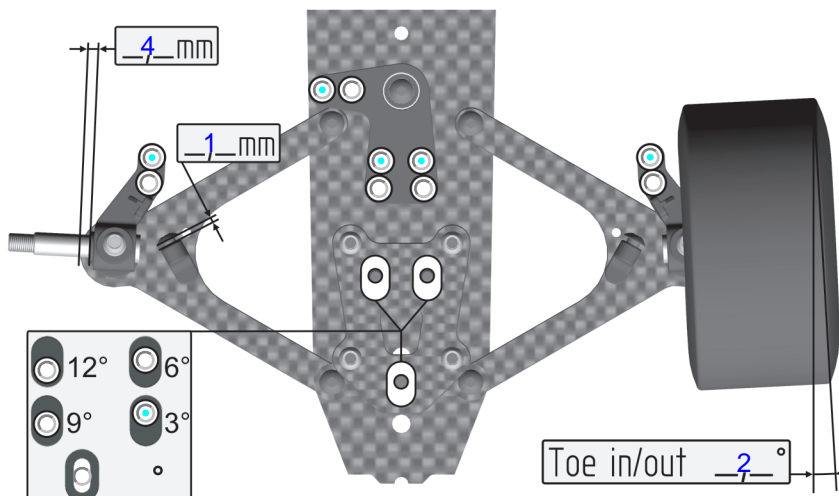

Name: Ronny Hoffmann  
 Date: 17.12.2017  
 Event: SPC 2018 Round1  
 Track: Indoor Spesbach  
 Surface:  Carpet  Asphalt  
 Traction:  high  medium  low  
 Layout:  technical  mixed  fast  
 Best lap: 11.823

### FRONT

### REAR

Volante Tyres: Volante  
 LRP Carpet 3 Additive LRP Carpet 3  
 5 Add. Timing 20  
 Additive treated area

Diff setting:  
 loose  medium  tight

Center shock:  
 Spring: Tamiya Red Piston: 3  
 Oil: 400 cSt Rebound: 20 %  
 F.p. spring: Soft  
 Length:      mm Preload:      mm

Side shock:  
 Spring: Xray 0.9 Oil: 20000 cSt

Gearing:  
88 T 34 T 2,58  
 Pinion Spur gear Drive ratio

Electronics:  
 Motor: Scorpion ETS  
 Speedo: Scorpion ETS  
 Battery: Muchmore 5000  
 Servo: Sanwa 801

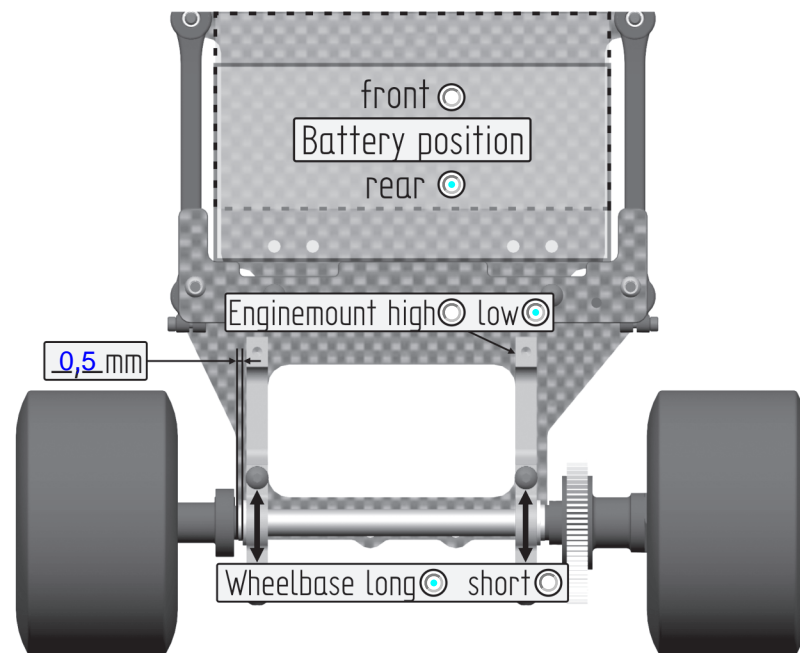
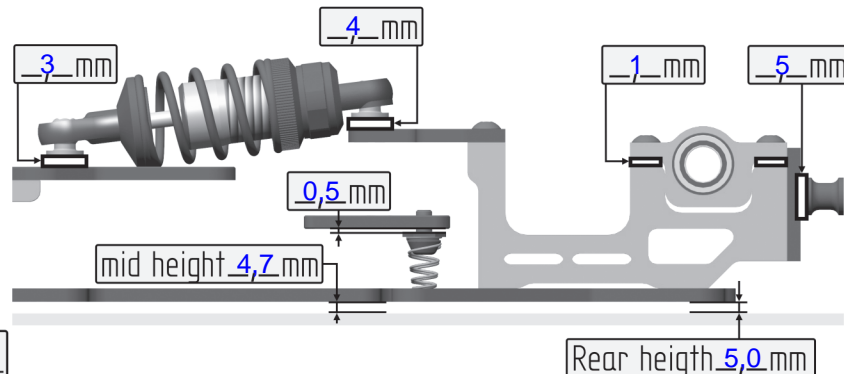

Body: Gonzo  
 Rear wing: Serpent  
 Front wing: Montec V2 2Flaps

Notes: Dämpfer Kurz  
Front: 10g gewicht  
Rear: 25gr. Pod Left

