

Camber right °

Camber left °

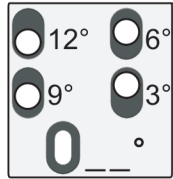

Toe in/out °

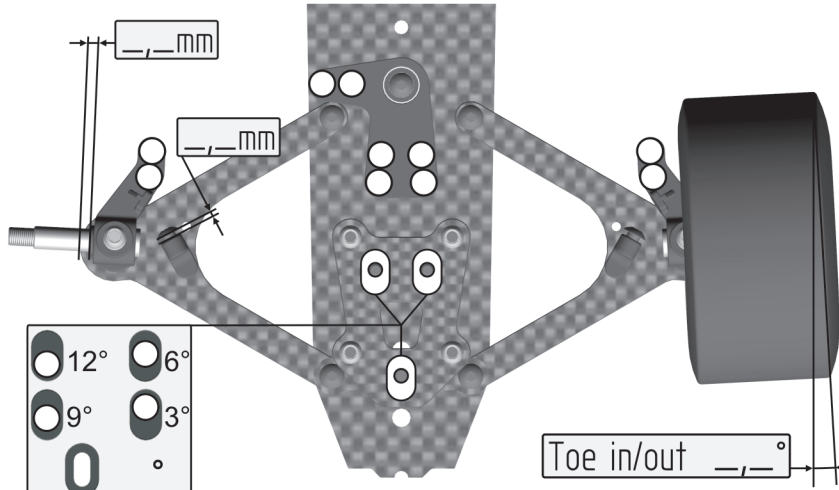
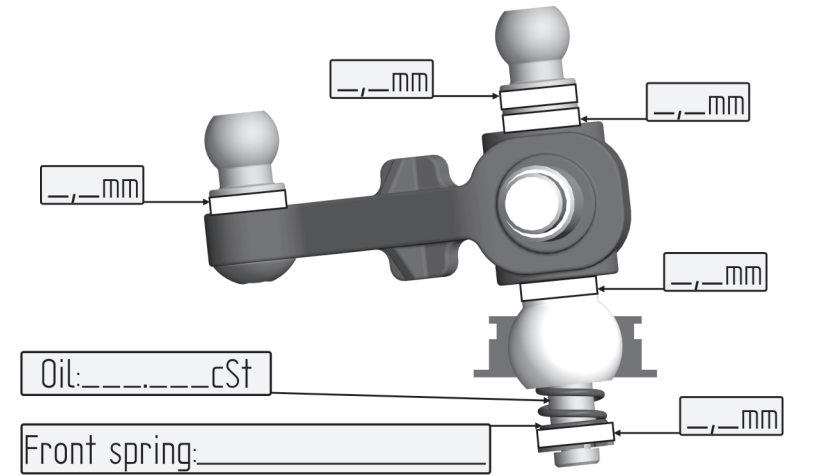
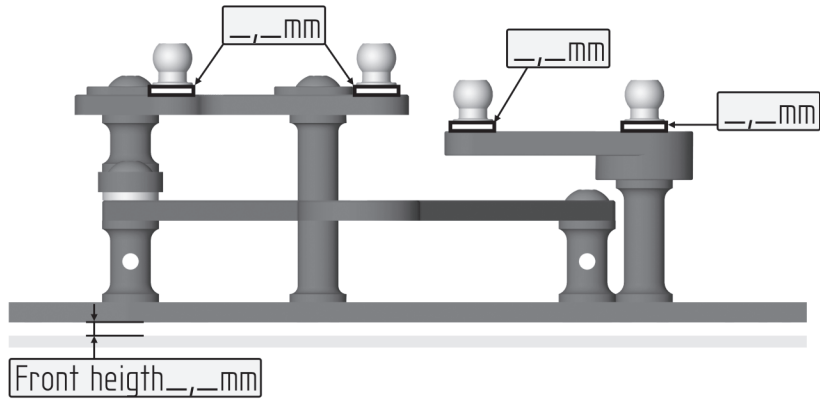

Name: _____
 Date: _____
 Event: _____
 Track: _____
 Surface: Carpet Asphalt
 Traction: high medium low
 Layout: technical mixed fast
 Best lap: _____

FRONT

REAR

Tyres: _____

Additive _____

Add. Timing _____



Additive treated area

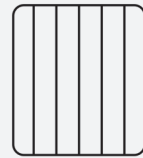

Diff setting:

loose medium tight

Center shock:

Spring: _____ Piston: _____
 Oil: _____ cSt Rebound: _____ %
 F.p. spring: _____
 Length: _____ mm Preload: _____ mm

Side shock:

Spring: _____ Oil: _____ cSt

Gearing:

 T T
 Pinion Spur gear Drive ratio

Electronics:

Motor: _____
 Speedo: _____
 Battery: _____
 Servo: _____

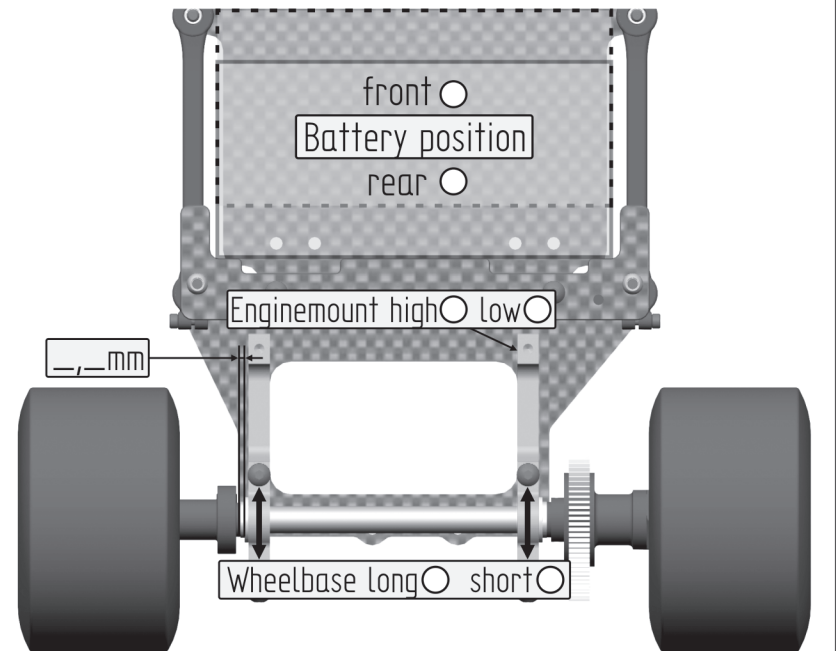
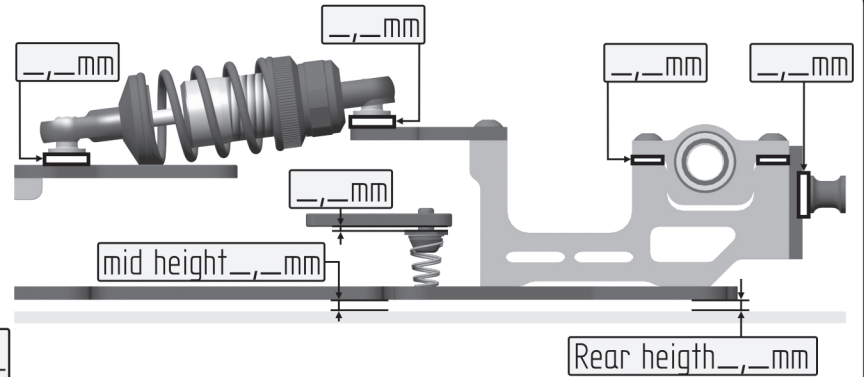

Body: _____
 Rear wing: _____
 Front wing: _____

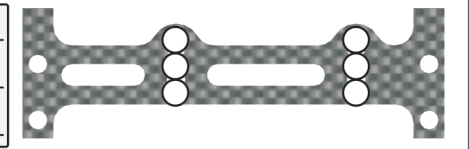

Notes: _____

