

**DRIVER, TRACK & RESULTS**

DRIVER *Hasse* COUNTRY *Sweden* WEATHER AIR TEMP *34c* TRACK TEMP  DRY  INTERMEDIATE  WET

TRACK *Lidköping* CONDITION  ASPHALT  CARPET  LOW  MEDIUM  HIGH  BUMPY  SMOOTH

RACE *NORDICS* DATE \_\_\_\_\_ QUALIFICATION *5* BEST LAP TIME \_\_\_\_\_ FINAL *5*

**FRONT DRIVE TRAIN** REAR

GEAR DIFF  GEAR DIFF *10k*

SPOOL

**HEAVE DAMPER**

OIL *2000* OIL *2000*

SPRINGS *Orange* SPRINGS *Orange*

SHIM mm SHIM mm

**ROLL DAMPER**

OIL *10k* OIL *10k*

SPRINGS *Red* SPRINGS *Pink*

HOLES HOLES

**REAR REACTIVE SYSTEM**

LONG RRS LINK  SHORT RRS LINK

SHIMS *0,5* mm

**TYRES** Controlled

BRAND/TYPE *Sweep 36*

INSERTS \_\_\_\_\_

ADDITIVE \_\_\_\_\_

TIME \_\_\_\_\_

SURFACE \_\_\_\_\_

**ELECTRONICS**

BATTERY \_\_\_\_\_

MOTOR *4,5 hobbywing* TIMING \_\_\_\_\_

ESC *Hobbywing* RECEIVER \_\_\_\_\_

SERVO \_\_\_\_\_ RADIO \_\_\_\_\_

**RATIO CONFIGURATION**

PINION *30* SPUR GEAR *114* PITCH *64*

FINAL RATIO \_\_\_\_\_ ROLLOUT \_\_\_\_\_ mm

**AERODYNAMIC CONFIGURATION**

BODY *Mon-tech RACER* WING \_\_\_\_\_

BODY POSITION \_\_\_\_\_ mm

*Car felt safe, was really high grip tarmac. Gonna try some more flex setup next time.*

**REMARKS**

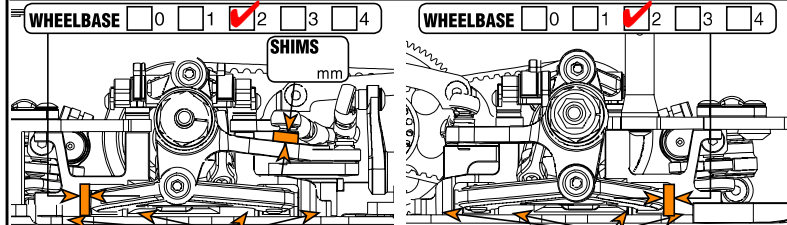
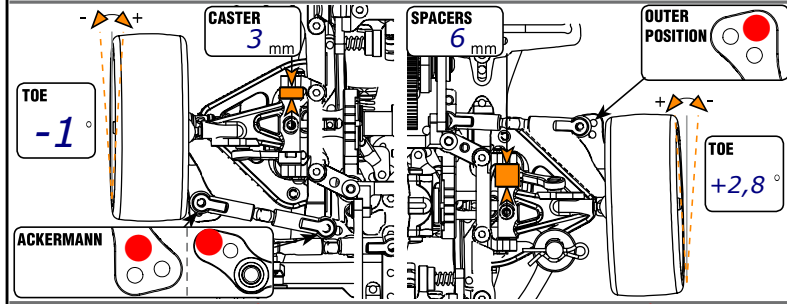
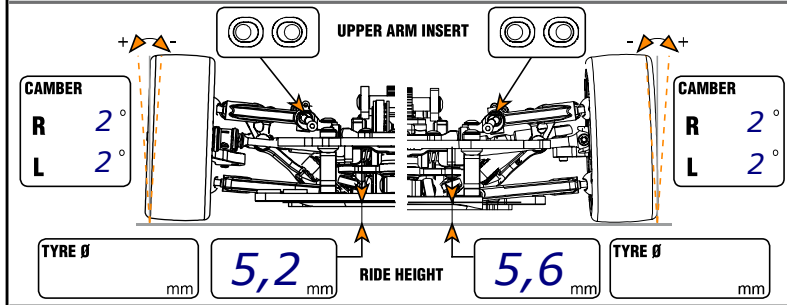
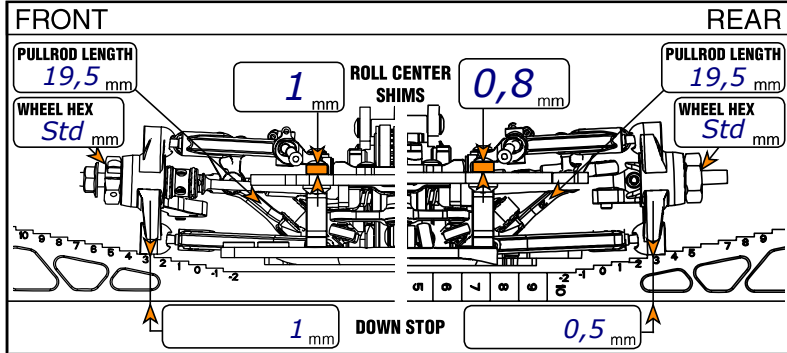

**ROLL CENTER BOTTOM INSERTS**

MID LOW MID HIGH HIGH

MID LOW MID HIGH HIGH

