

F110 SFD

Instruction Manual



Serpent

EP

1/10 scale 2wd

INTRODUCTION

Serpent developed the Serpent F110 SF3 model car for demanding racers in the highly competitive electric 1/10th scale F1 class, which like all our previous cars, has been designed to win straight from the box.

Featuring a number of very effective features such as a fully adjustable front end, machined aluminium rear pod, side-links combined with ball-link tube-system to control chassis roll and grip, top-mounted shockabsorber, quick and easy tweak adjustment and top quality materials throughout, the F110 SF3 should see you in the winners circle in no time. In fact everything associated with this car is of the highest quality, from the packaging and supplied online manuals, right through to the product and race support.

For latest information about F110 SF3 check on: www.serpent.com/410065

Enjoy racing !

Team Serpent
Multiple World Champions

INSTRUCTIONS

Serpent's long tradition of excellence extends to the instruction manuals, and this instruction manual is no exception. The easy-to-follow layout is richly illustrated with 3D-rendered full-color images to make your building experience quick and easy. Following the instructions will result in a well-built, high-performance race-car that will soon be able to unleash its full potential at the racetrack. The kit includes bags, with bagnumbers, which refer to the same step in the manual. Open only the indicated bag(s) per step and finish that part of the assembly. Remaining parts will be needed later on in the assembly process.

PLASTIC PARTS

The Serpent moulded parts are very durable and hard. When assembling longer screws in new composite parts, make sure to use new hex bits in your (power) tools. Pre-threading also helps to avoid screw damage.

SETUP

In certain assembly steps you need to make basic adjustments, which will give you a good initial setup for your Serpent Spyder SDX4. Fine-tuning the initial setup is an essential part of building a high-performance racecar like your Serpent Spyder SDX4.

EXPLODED VIEWS AND PARTS LIST

The exploded views and parts lists for the Serpent Spyder SDX4z are presented in the Reference Guide section in the back of this manual. The exploded views show all the parts of a particular assembly step along with the Serpent part number and hotlink to the Serpent website. Partnumbers in orange indicates that this part is an optional. Optionals part names and numbers are showed below.

CUSTOMER SERVICE

Serpent has made a strong effort to make this manual as complete and clear as possible. Additional info may be published in our website: www.serpent.com or you may ask your dealer or the Serpent distributor for advice, or email Serpent direct: info@serpent.com. The Serpent Facebook, Twitter and Youtube pages give additional means of support and communications.

SAFETY

Read and take note of the 'Read this First section' before proceeding to assemble the car-kit. This car-kit is intended for persons aged 16 or older.

READ THIS FIRST!

- This is a highly technical hobby product, intended to be used in a safe racing environment. This car is capable of speeds in excess of 80 km/h or 50mph. Please follow these guidelines when building and operating this model.
- Parental guidance is required when the builder/user of this car is under 16.
- Follow the building instructions. If in doubt, contact your dealer or importer.
- Be sure to use the proper tools when assembling the car. Always exercise caution when using electric tools, knives and other sharp objects.
- Be careful when using liquids like lubrication oil, fuel or glue. Do not swallow.
- Follow the manufacturer's instruction in case you experience irritation after using the product.
- Be careful when operating the car. Stay away from any rotating parts such as wheels, gears and transmission. Stay away from motor, engine and exhaust pipe system or speedo during and immediately after use, as these parts may be very hot. We advise to use protective hand gloves.
- Only operate this car in a safe environment, like a special racing track or a closed parking lot. Avoid using this car on public roads, crowded places or near infants.
- Before operating this car, always check the mechanical status of the car. Also check that the transmitter and receiver frequencies correspond and are not used by any other racer at the same time. Check that the batteries of the transmitter and receiver- are fully charged.
- After use, always check all the mechanics of the car. We advise to clean the car immediately after use, and inspect the parts for wear or fractures. Replace when necessary. Do not use water, methanol, thinner or other solvents to clean the car.
- Empty the fuel tank (depending on model) if needed and disconnect the receiver battery.
- Store the car in a dry and heated place to avoid corrosion of metal parts.
- Avoid using this car in wet conditions as the water will cause corrosion on the metal parts and bearings and these parts will cease to function properly. If driven in the wet, ensure that all the electric equipment is waterproofed and after use, that all moving parts are dried immediately.

CONTENTS

• FRONT ASSEMBLY	4
• REAR ASSEMBLY	10
• CENTRAL ASSEMBLY	12
• BALL DIFF ASSEMBLY	15
• ELECTRONICS ASSEMBLY	17
• SHOCK ASSEMBLY	22
• FINAL ASSEMBLY	25
• EXPLODED VIEWS	31
• TEAM SERPENT NETWORK	38

LINES DESCRIPTION

Each step contains a variety of numbers, lines, and symbols. The numbers represent the order in which the parts should be assembled. The lines are described below.



Step number; the order in which you should assemble the indicated parts



Length after assembly



Assembly path of one item into another



Group of items (within lines) should be assembled first



Direction the item should be moved



Glue one item to another



Connect one item to another



Gap between two items



Press/Insert one item into another

ICONS DESCRIPTION

Each step contains a variety of symbols described below.



Carefull, read and check very well.



Apply a small amount of cyano glue. Use wear protection for eyes and hands.



Detail view to explain assembly or order of parts better.



Default set-up: This symbol indicates the default setup.



Grease: apply a small amount of grease to the parts shown.



Silicone grease: apply a small amount of grease to the parts shown.



Thread lock: apply a small amount on the parts shown. Before to apply the threadlock, make sure to degrease the parts very well, as otherwise the threadlock will not work.



Silicone oil: use the indicated silicone oil for the shocks and differentials.



Oil: apply a small amount of oil to the parts shown.



Left and right parts should be assembled in the same way.



Parts or items not included in the kit.



Optional part, not standard in the kit.

STEP 1

BAG 1

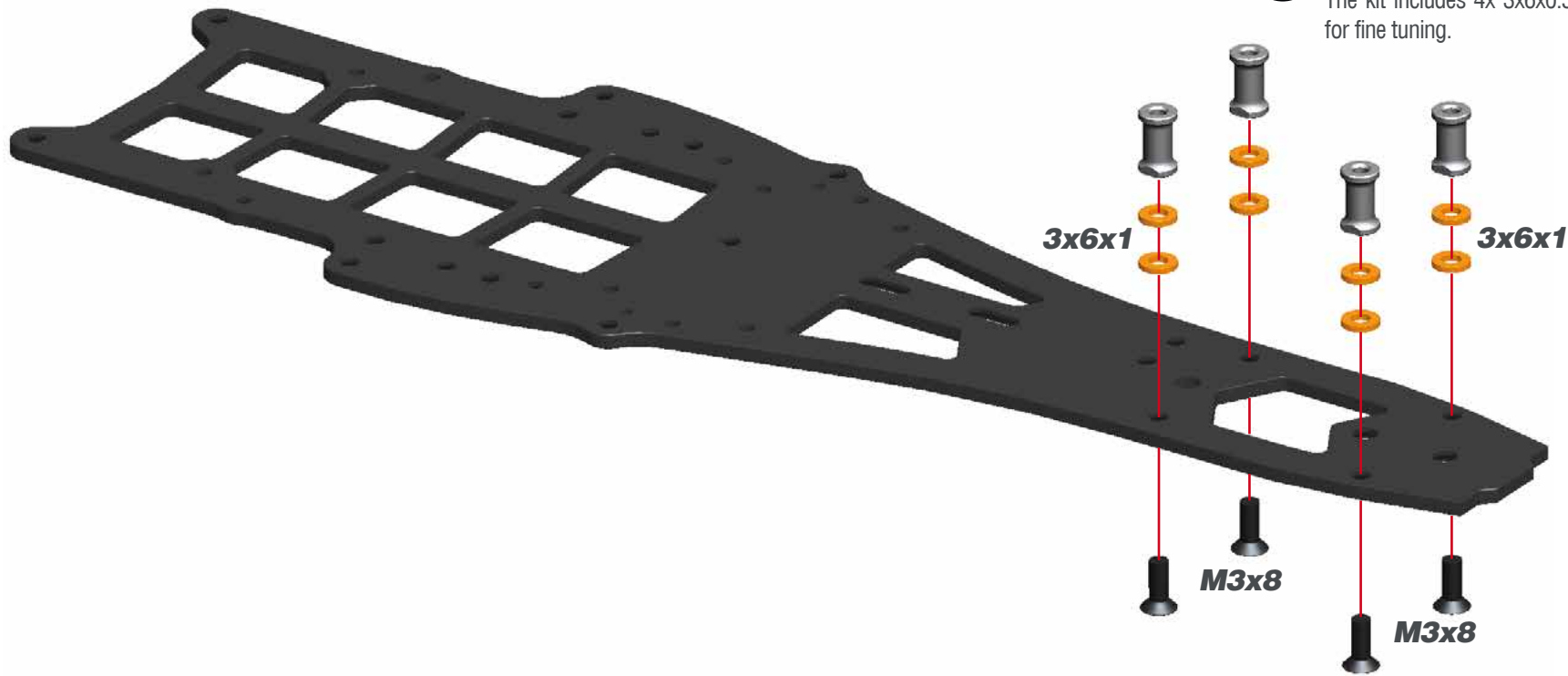

As default adjustment of the front ride height should be assembled 2x 3x6x1 ride height spacers. The kit includes 4x 3x6x0.5mm ride height spacers for fine tuning.



M3x8



3x6x1



3x6x0.5

STEP 2

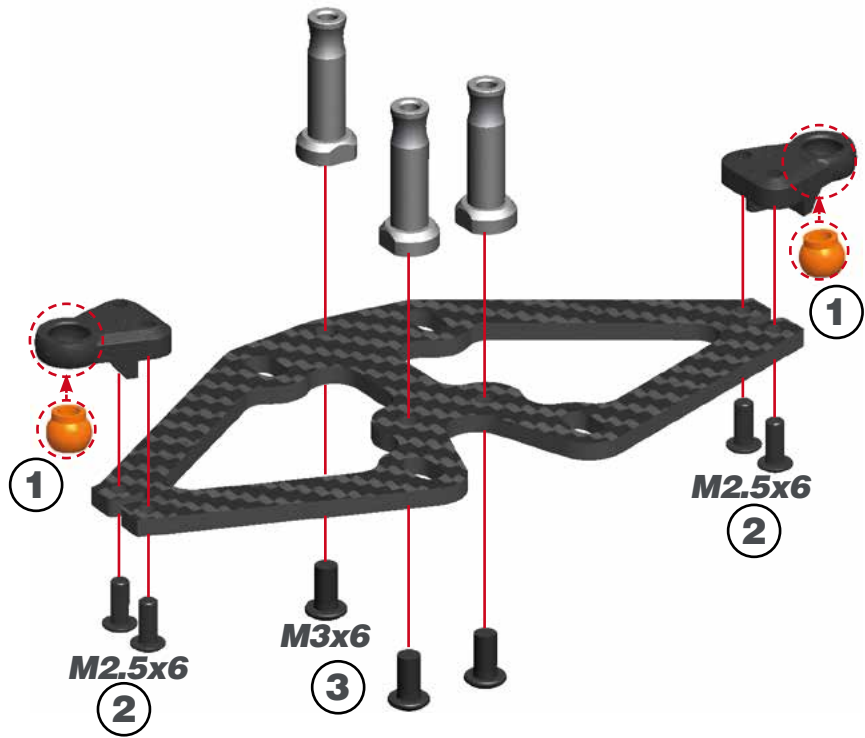

STEP 3

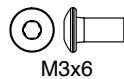
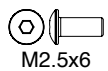
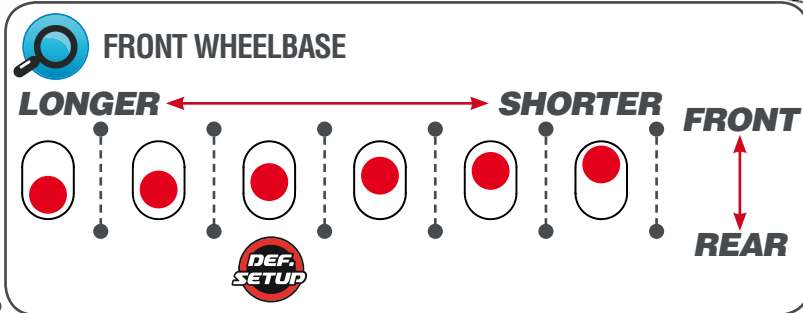
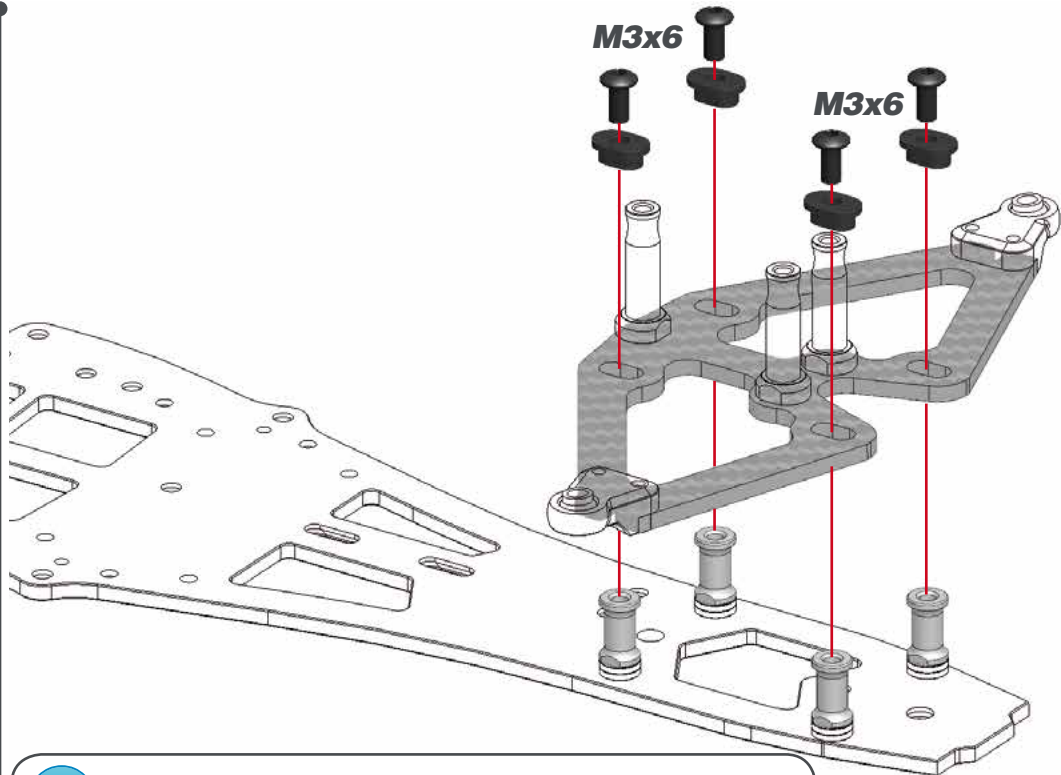

STEP 4

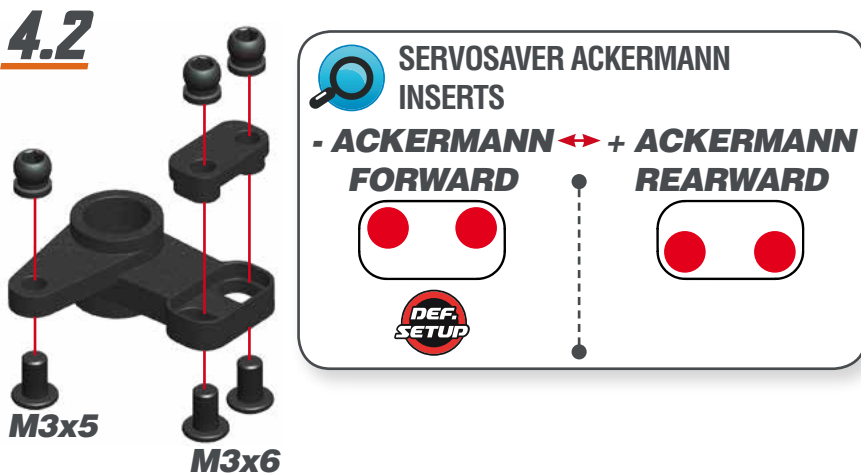

STEP 5

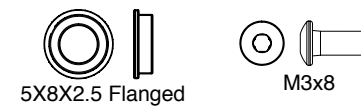
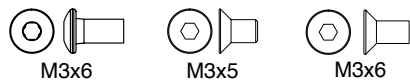
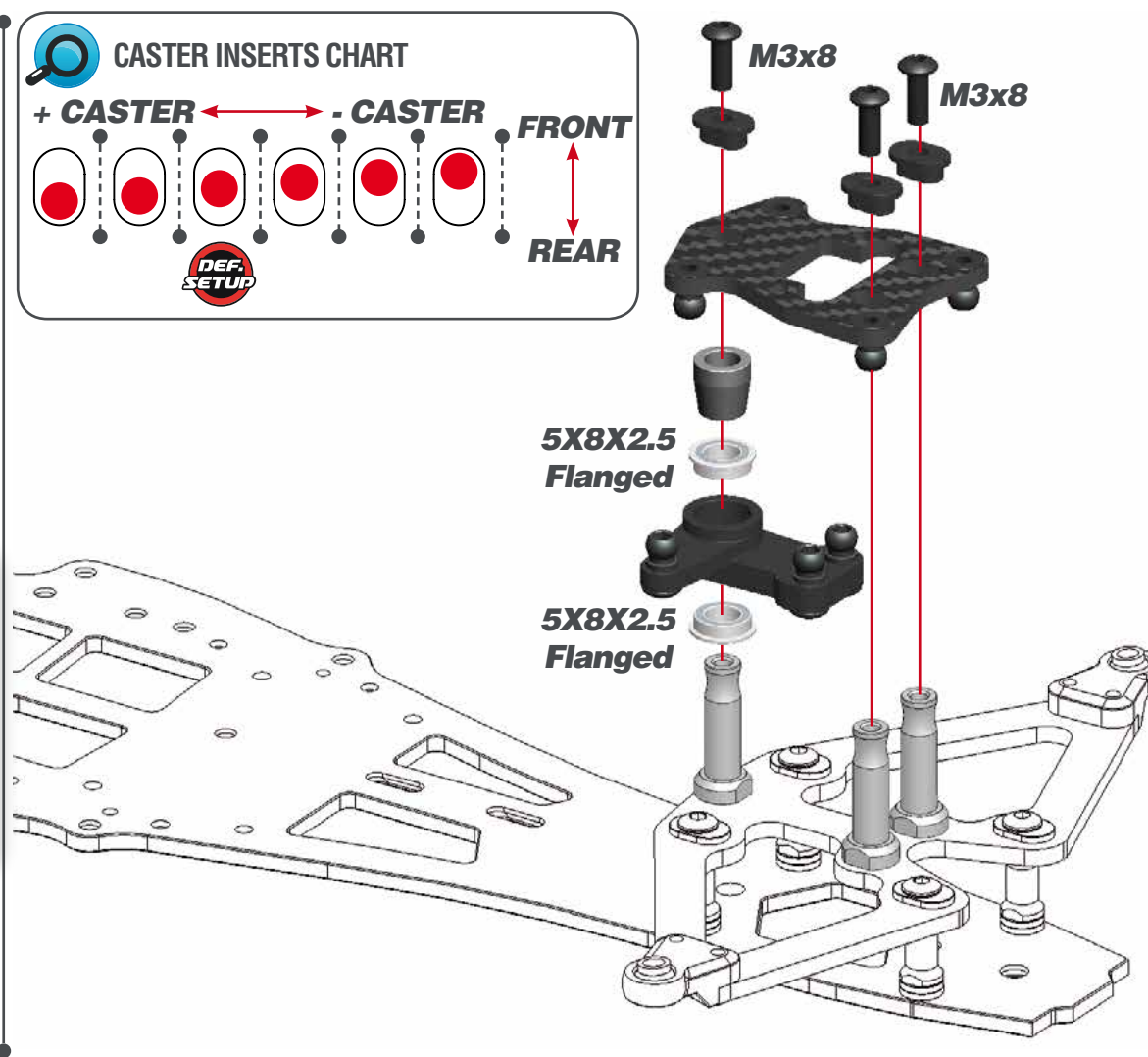



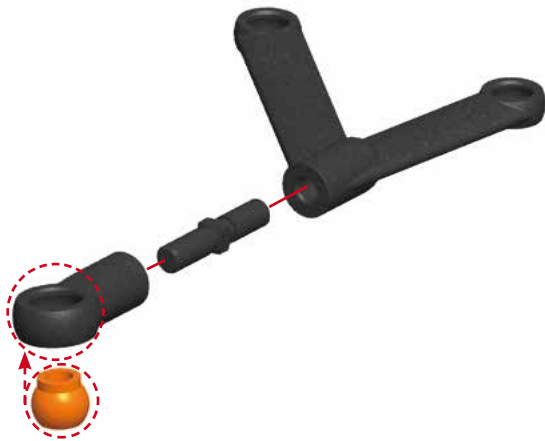

STEP 6

BAG 2

STEP 7



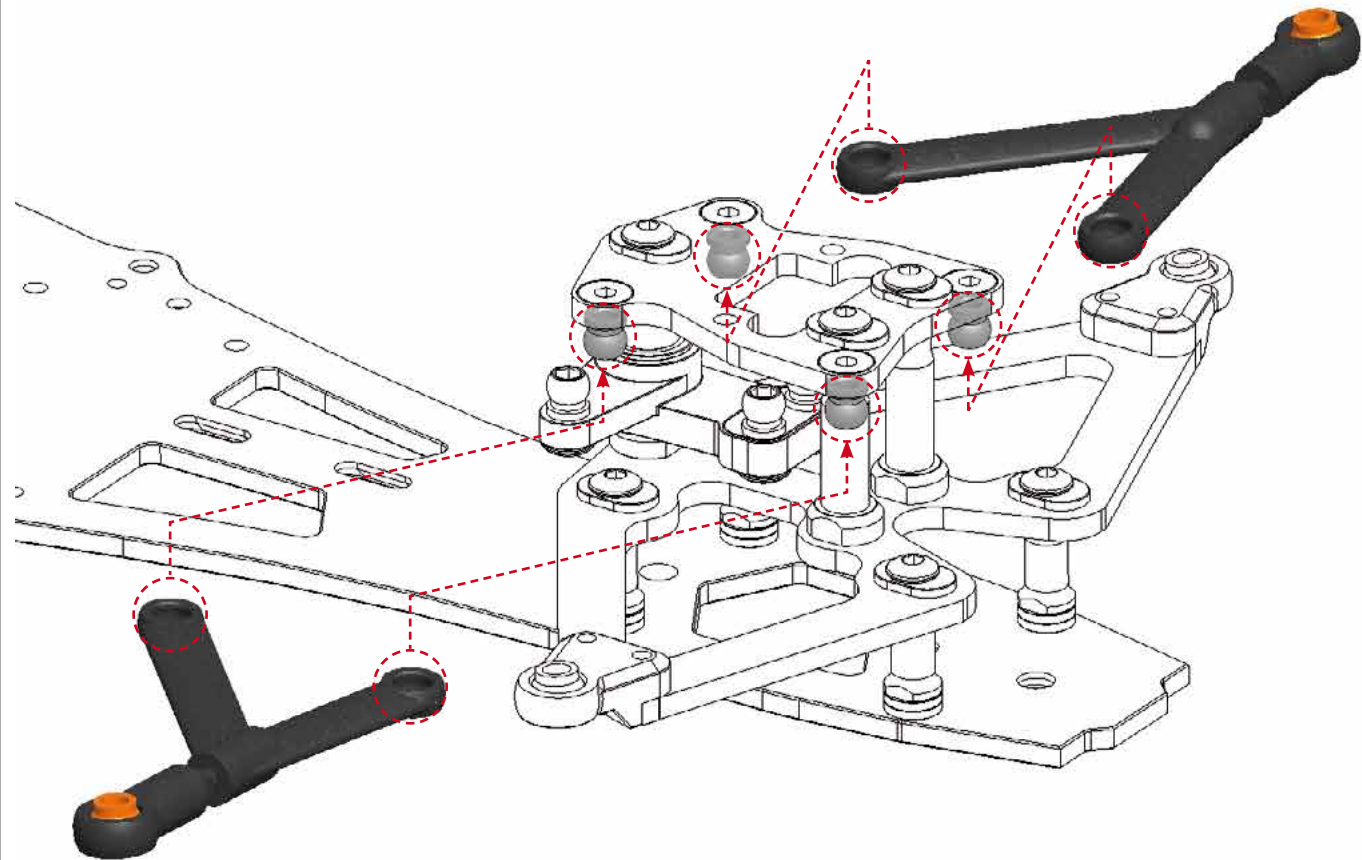

FRONT CAMBER
 4 mm

STEP 8

STEP 9

L=R
3x5x2
Nylock Nut M3
M3x8

Right steering block assembly

L=R **ACKERMANN POSITION**

DEF. SETUP

KING PIN INSERTS CHART

King pin angle adjustable from 0 to 4 degrees.

0°	1°	2°	3°	4°
DEF. SETUP				

1 **R2.3**

2

3x5x2

3

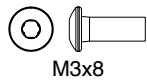

4

R2.3



STEP 10



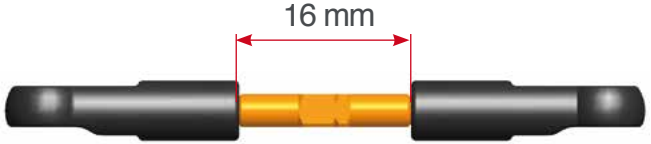

STEERING TRACKROD LENGTH
 16 mm

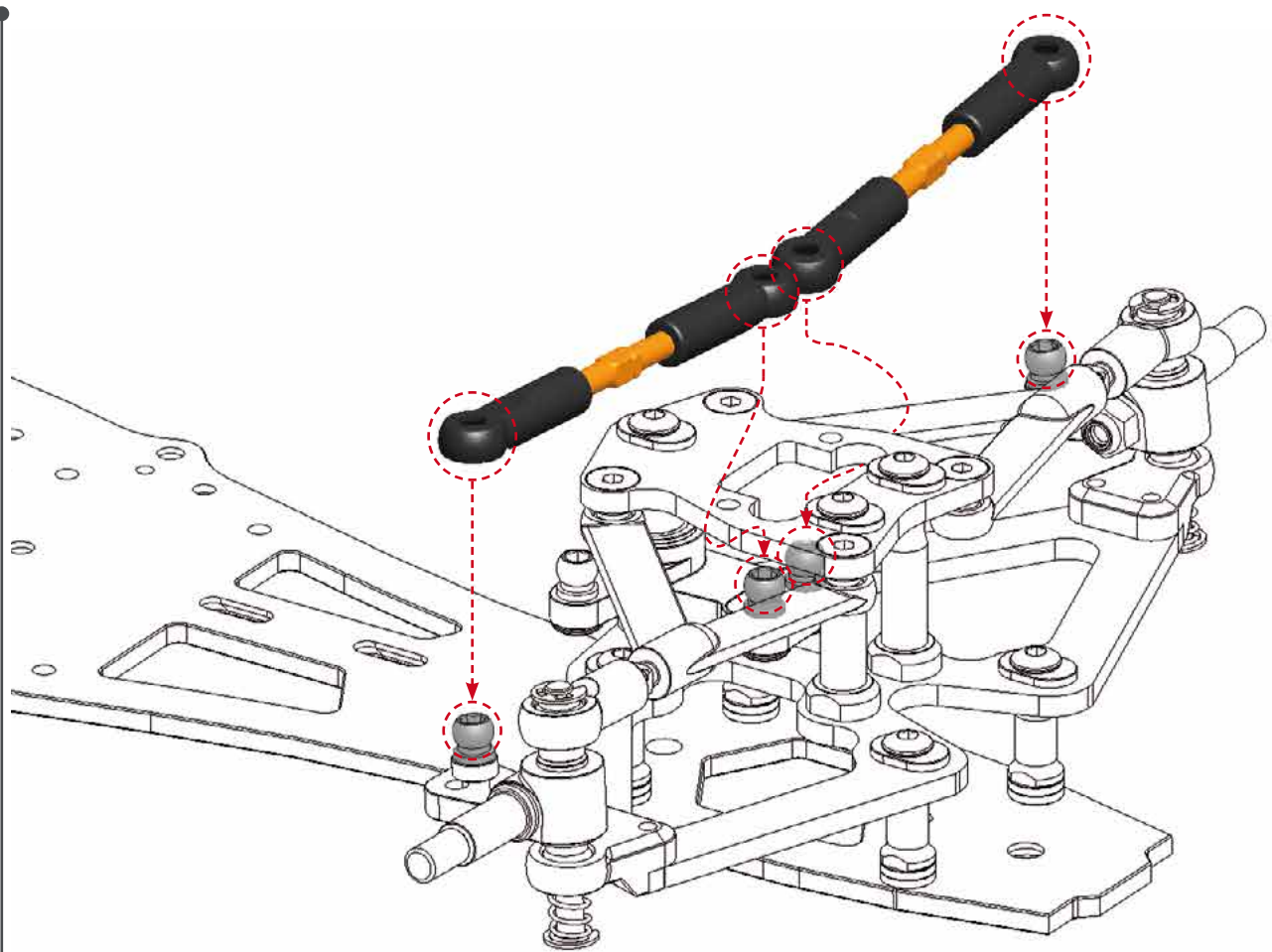

STEP 11



STEP 12

BAG 3

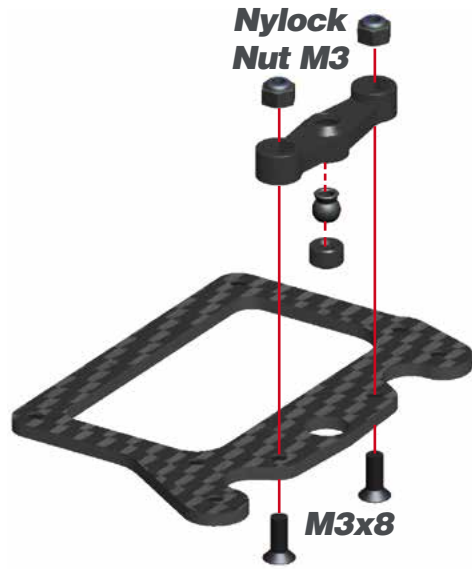

STEP 13

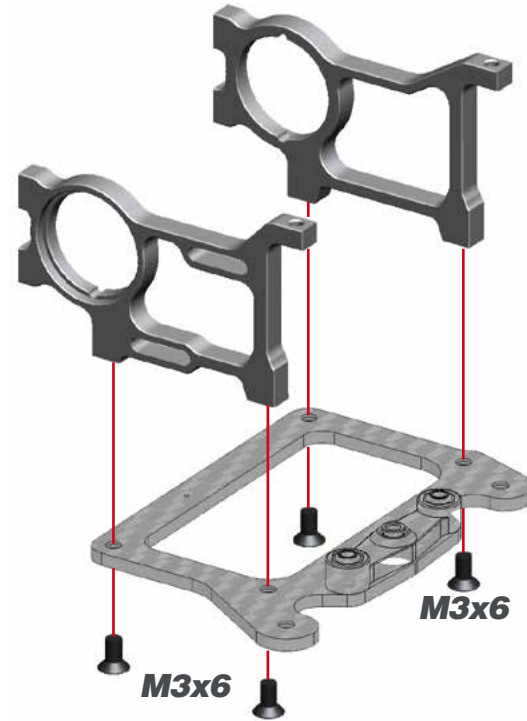

STEP 14

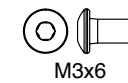
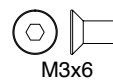
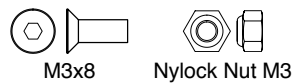
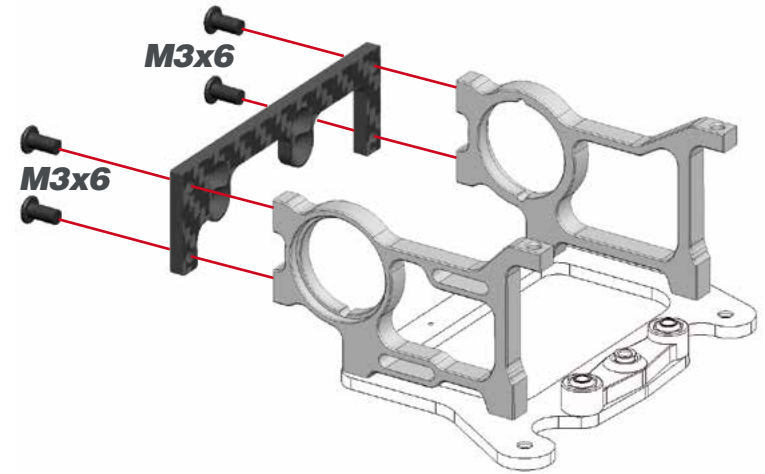

STEP 15 **BAG 4**

STEP 16

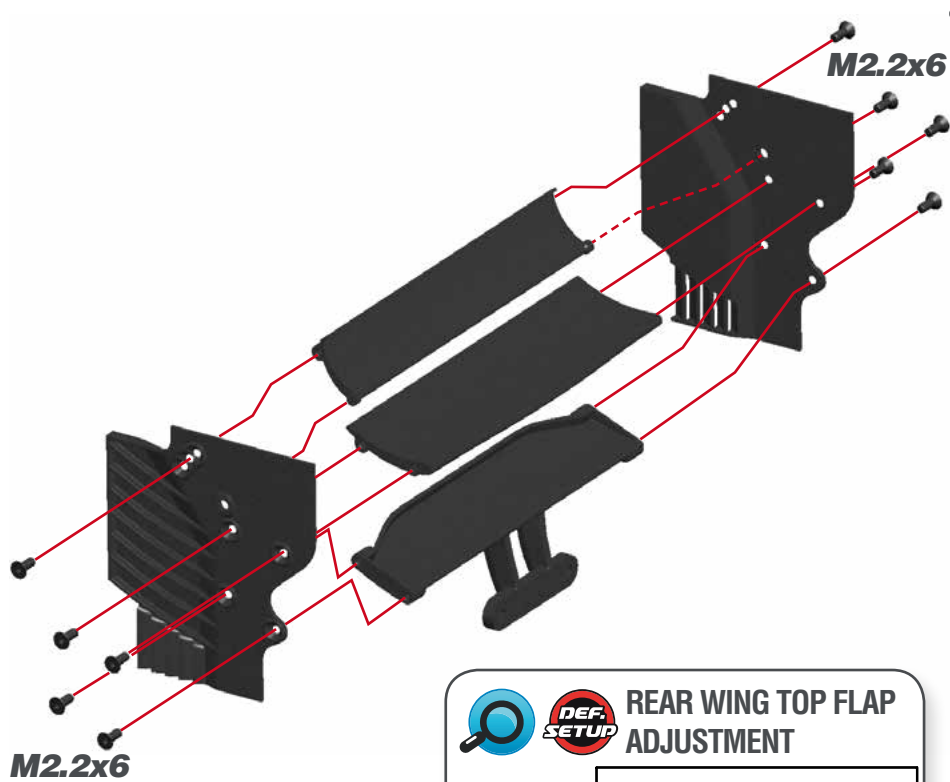

REAR WING TOP FLAP ADJUSTMENT

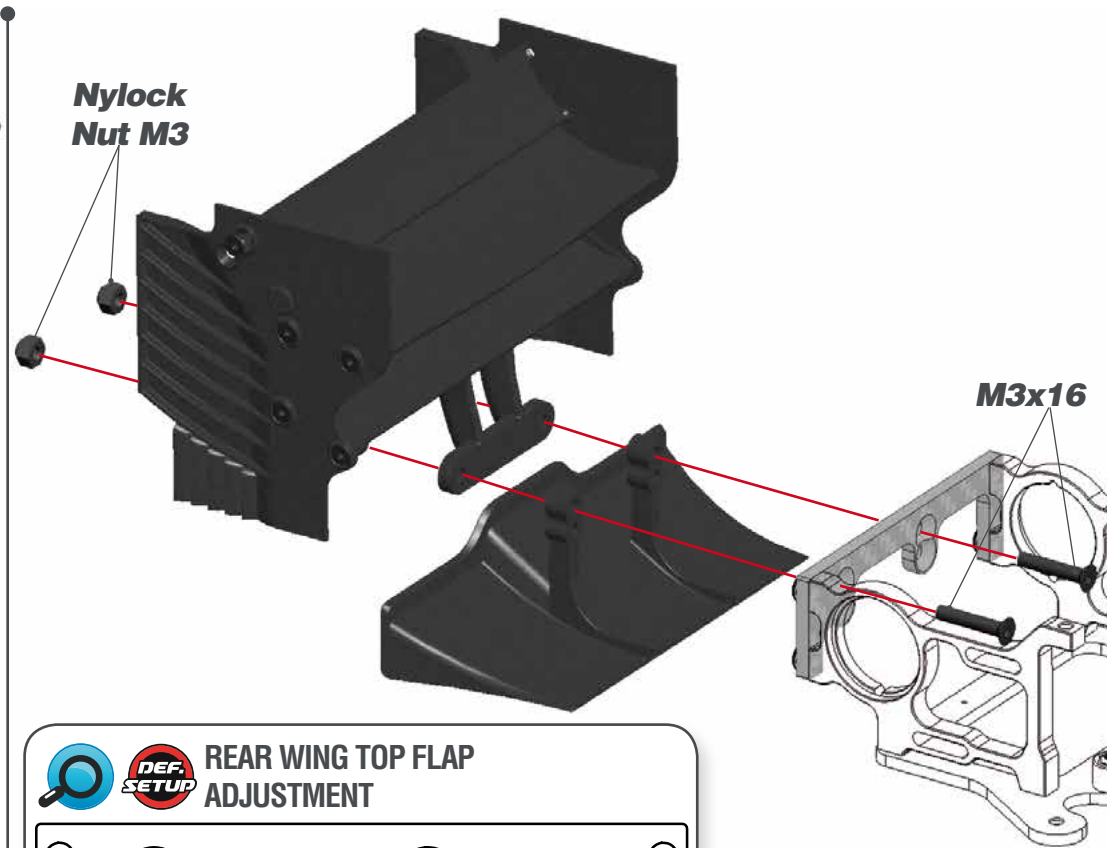

REAR WING TOP FLAP ADJUSTMENT

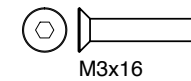
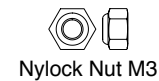

STEP 17 BAG 5

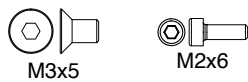
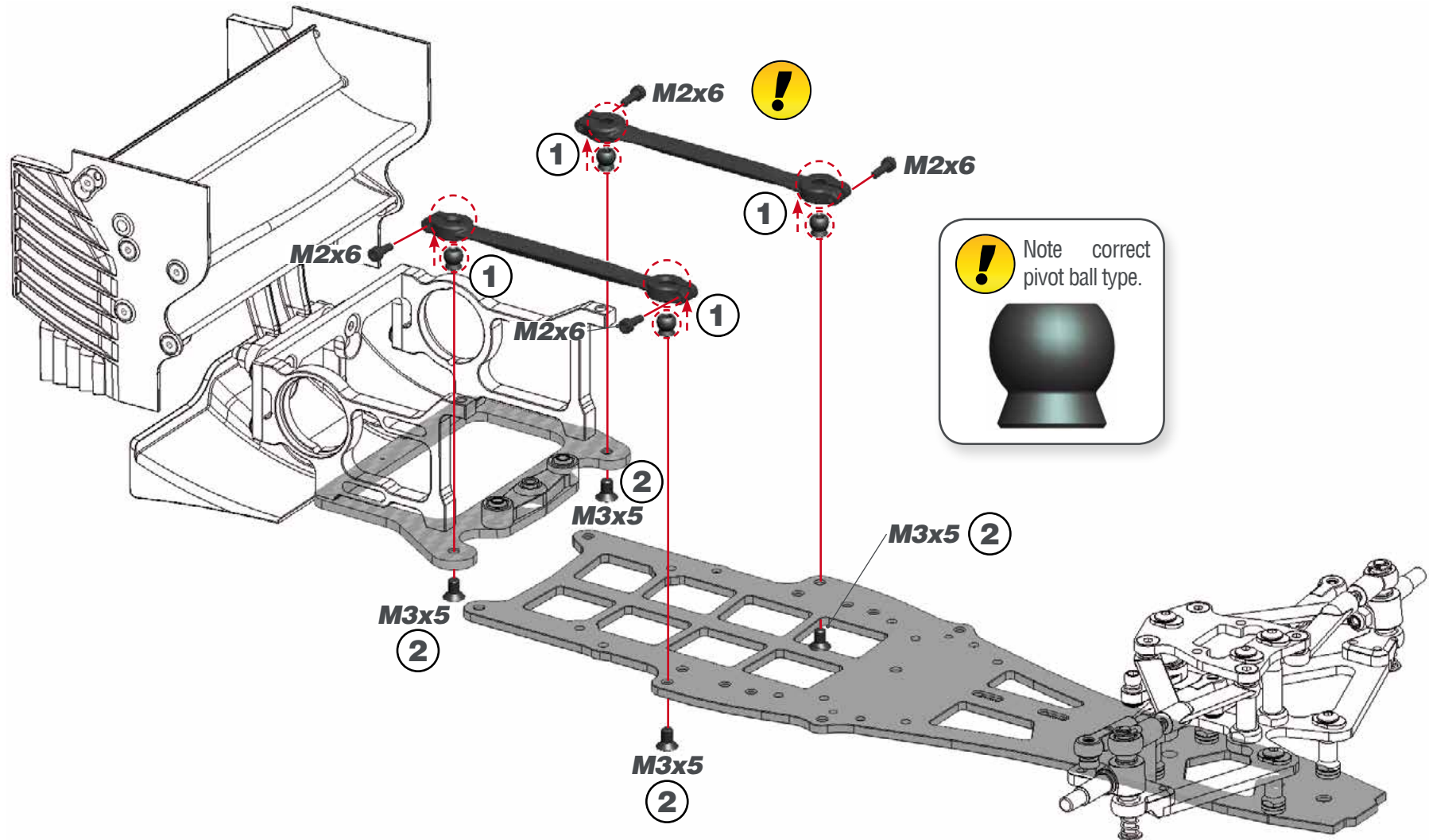

STEP 18

! Note correct pivot ball type.

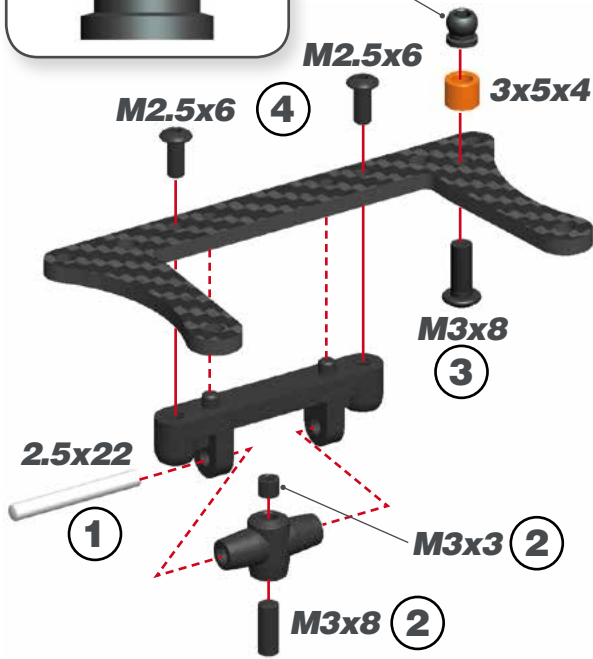

STEP 19

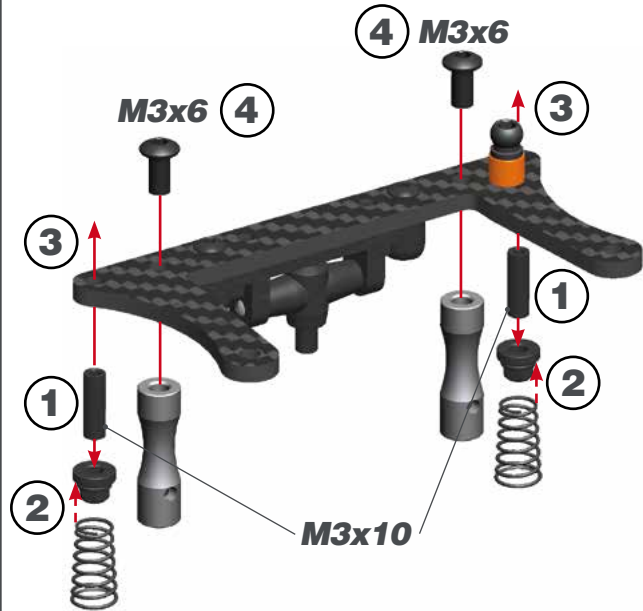

STEP 20

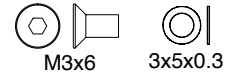
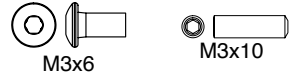
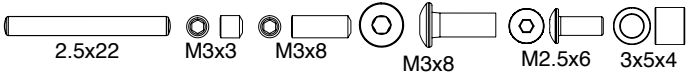
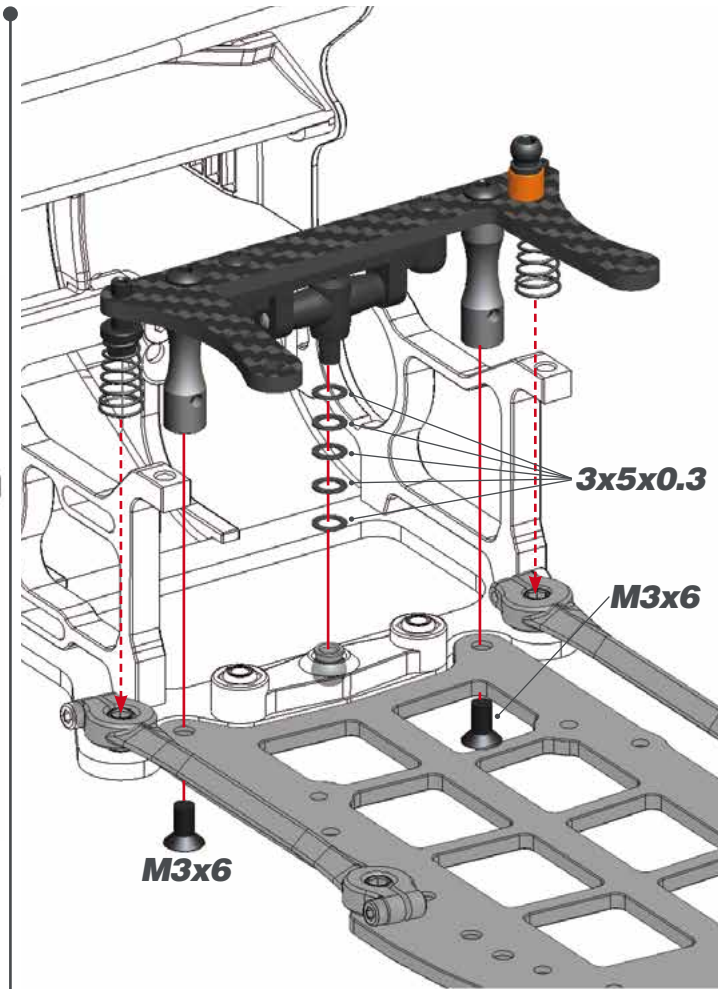

STEP 21

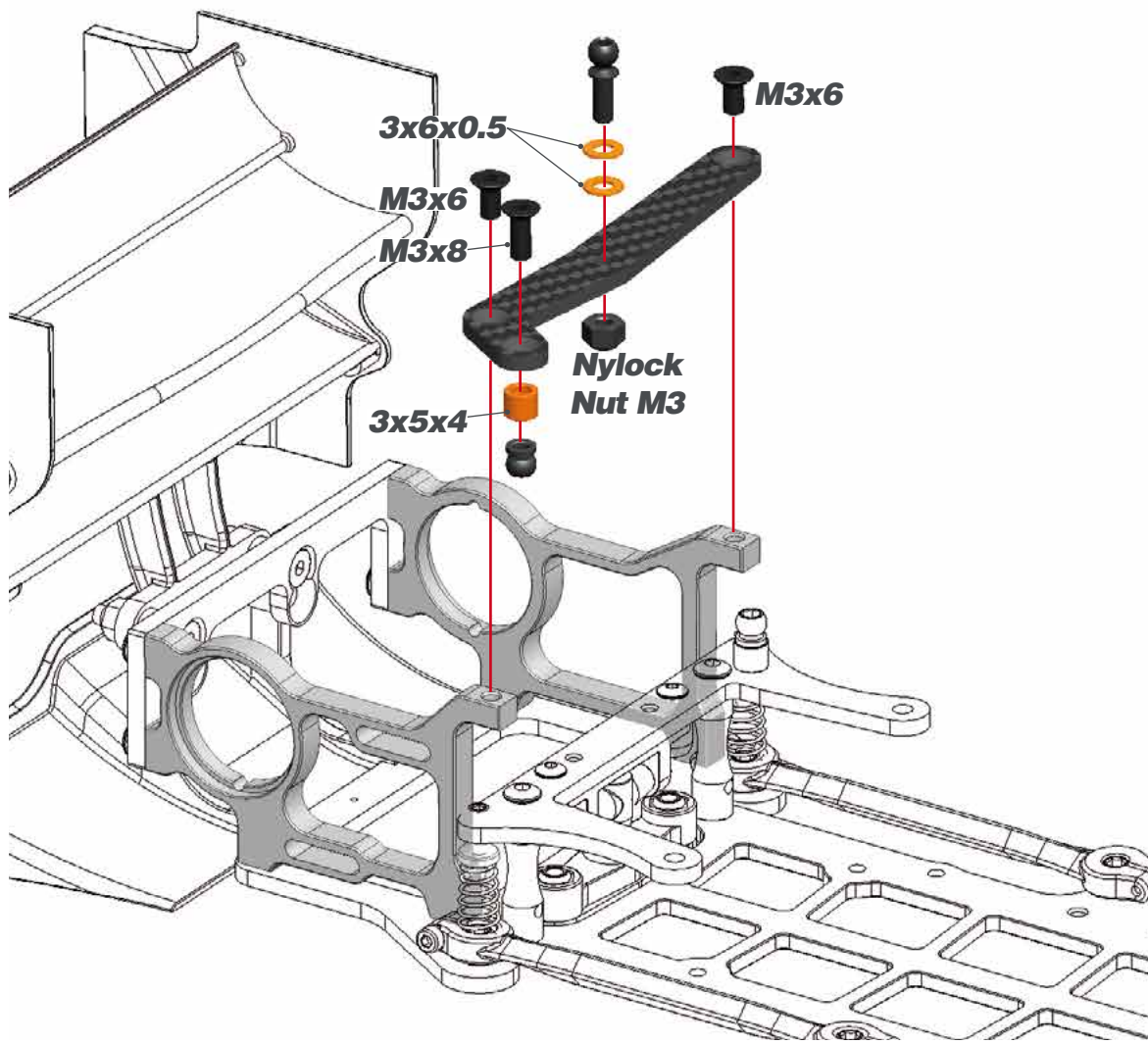



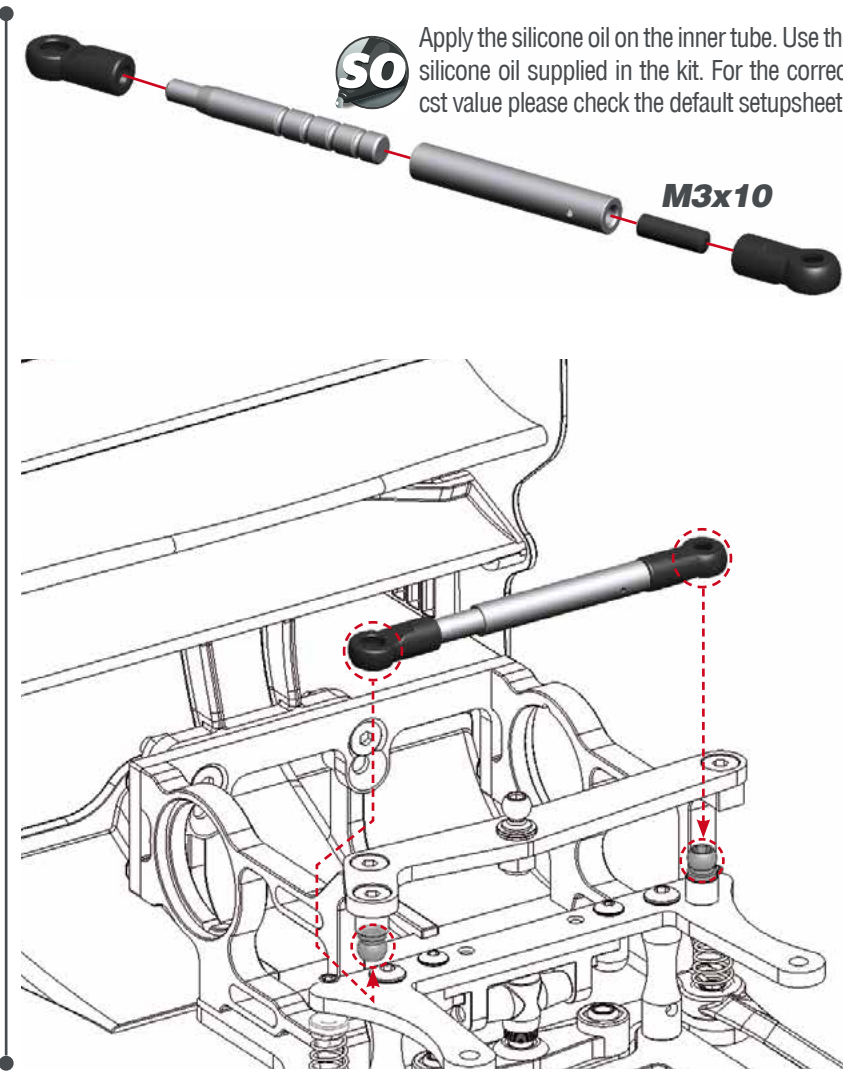

STEP 22



50

Apply the silicone oil on the inner tube. Use the silicone oil supplied in the kit. For the correct cst value please check the default setupsheet.

M3x10

- 
 3x6x0.5
- 
 3x5x4
- 
 M3x6
- 
 M3x8

- 
 M3x10

STEP 23 BAG 6

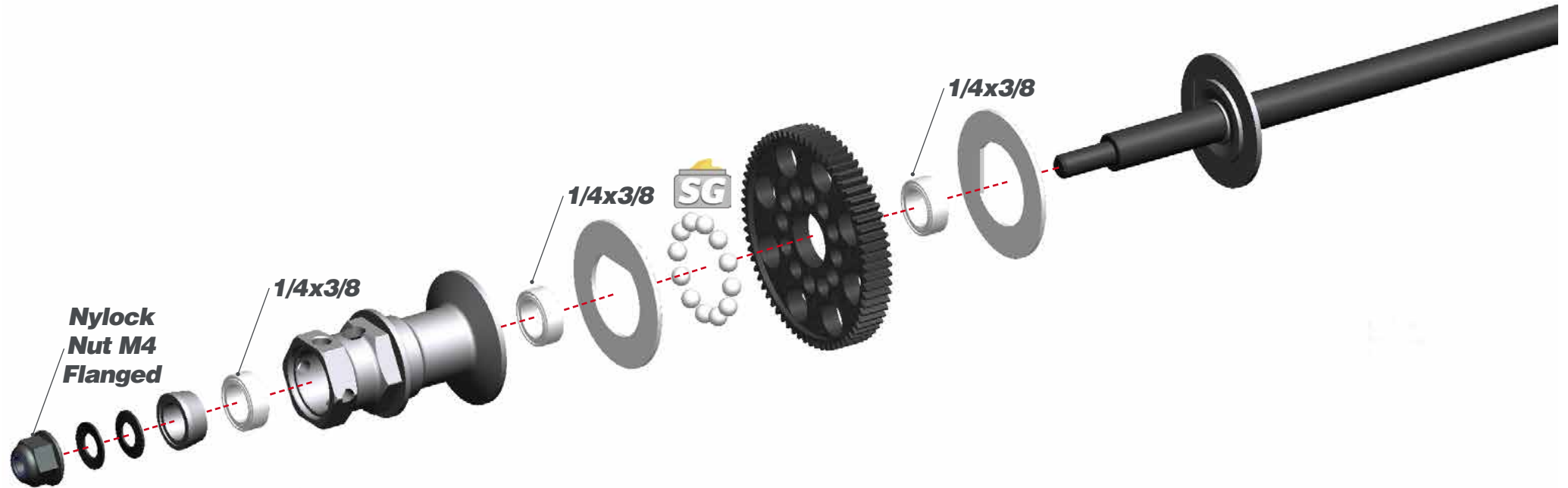

Note correct shims orientation.



Nylock Nut
M4 Flanged

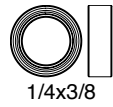

1/4x3/8

STEP 24

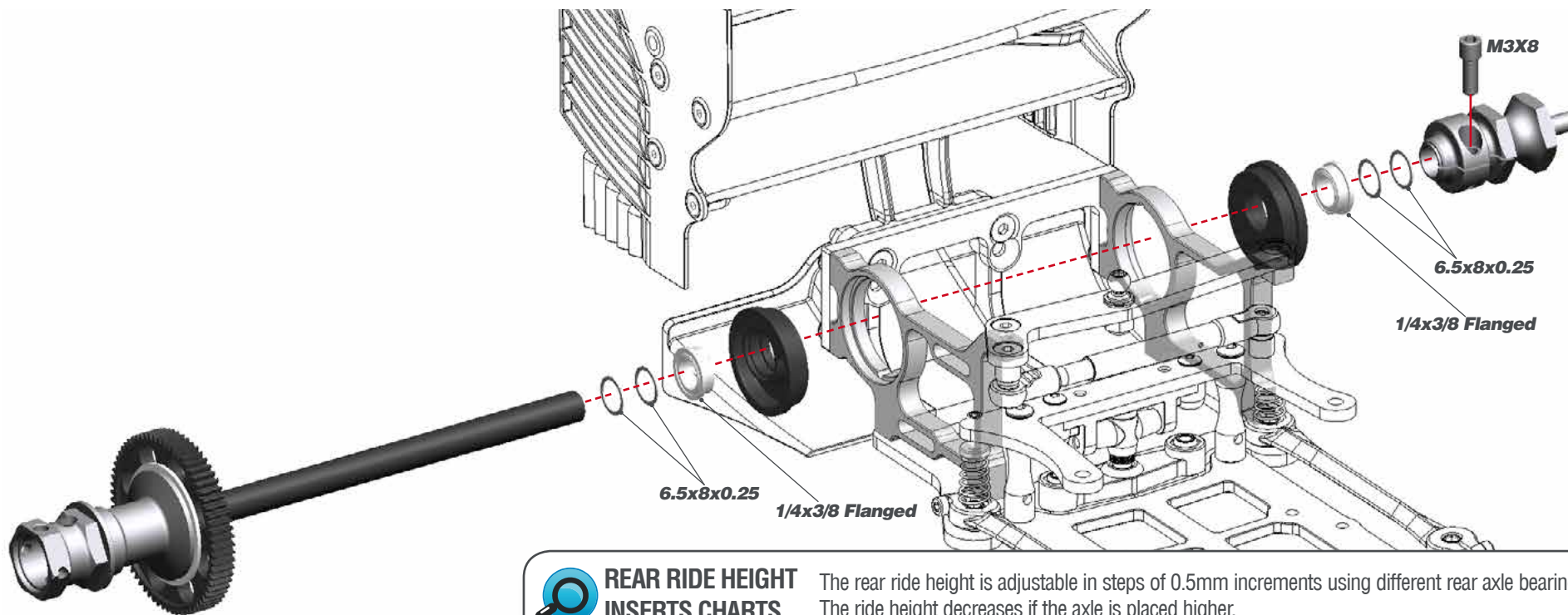

REAR RIDE HEIGHT INSERTS CHARTS The rear ride height is adjustable in steps of 0.5mm increments using different rear axle bearing adapters. The ride height decreases if the axle is placed higher.

0\0	0\05	0\10	0\15	0\20	0\25	0\30	0\35	0\40

DEF. SETUP



STEP 25 BAG 7

REARWARD SERVO CONFIGURATION **DEFAULT**

25.1

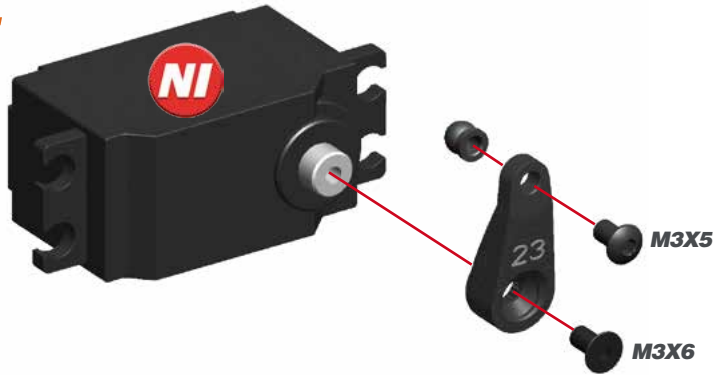

FORWARD SERVO CONFIGURATION **OPTIONAL**

25.1



25.2

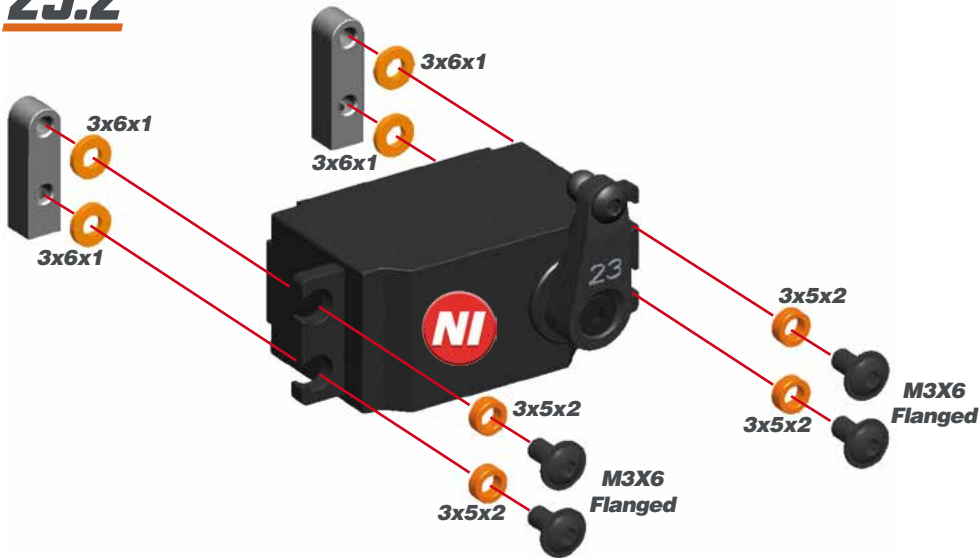

25.2

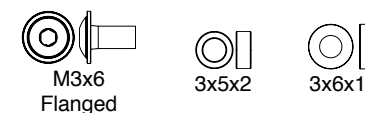
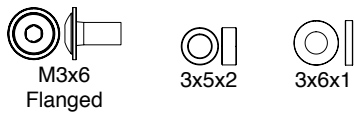
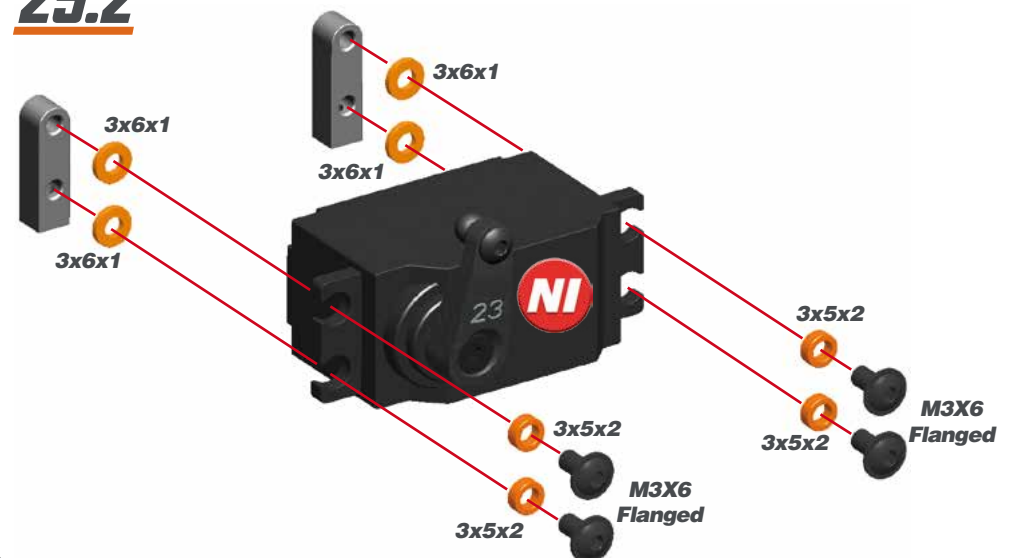

STEP 26

REARWARD SERVO CONFIGURATION *DEFAULT*

FORWARD SERVO CONFIGURATION *OPTIONAL*

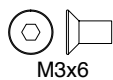
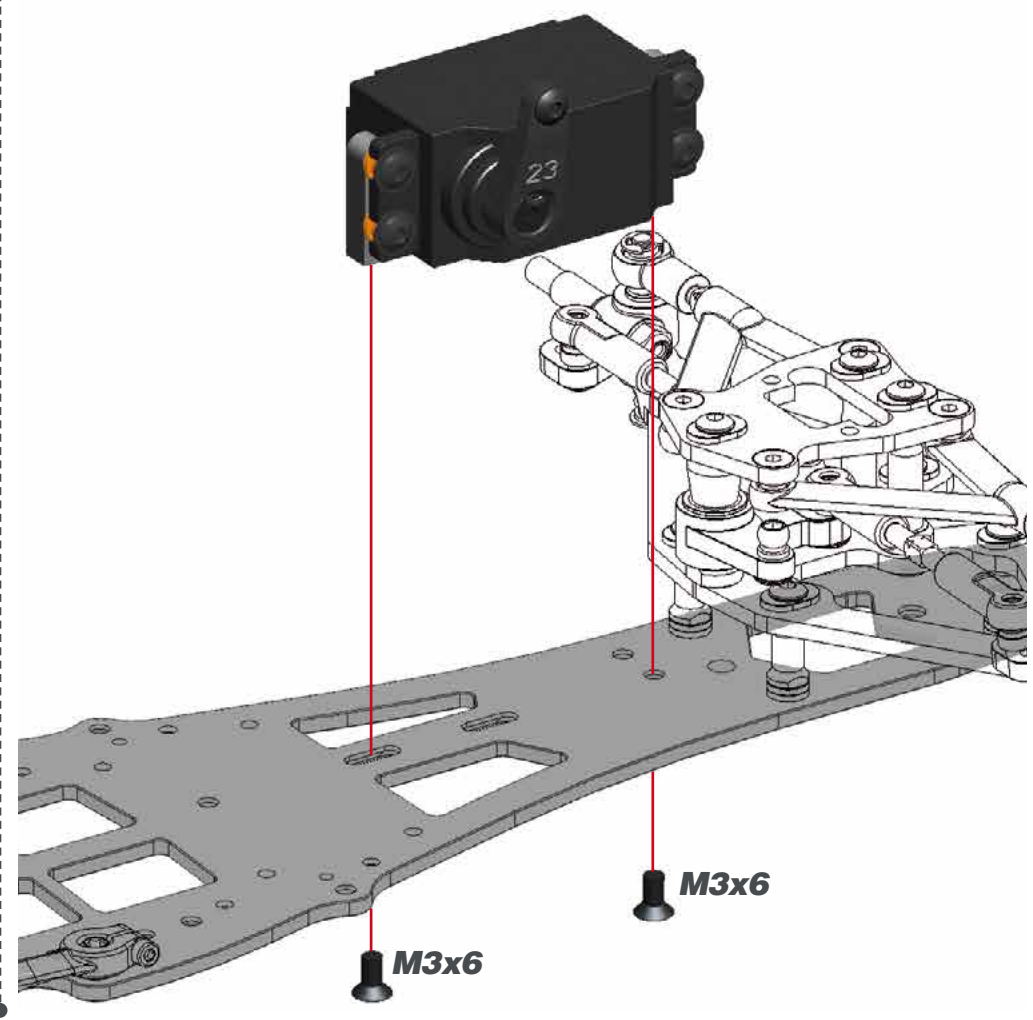
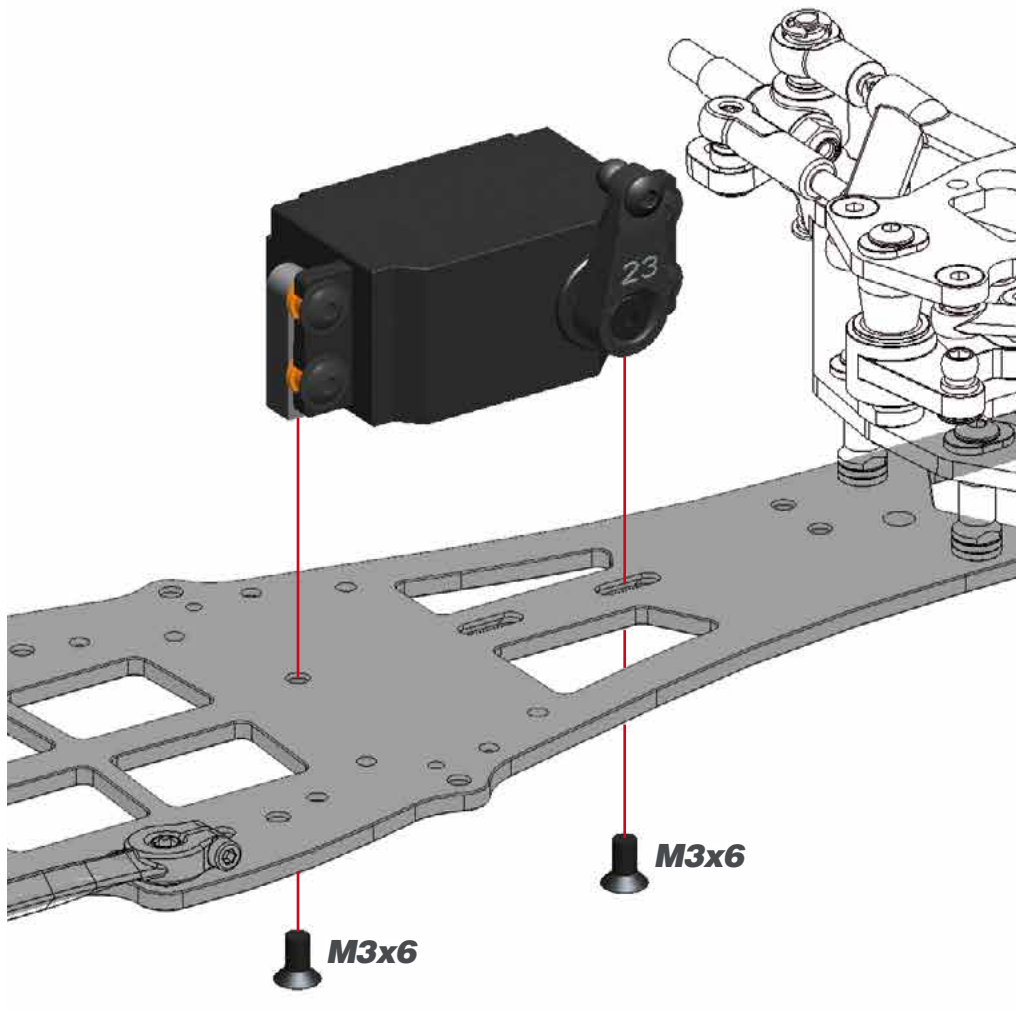

STEP 27

REARWARD SERVO CONFIGURATION **DEFAULT**

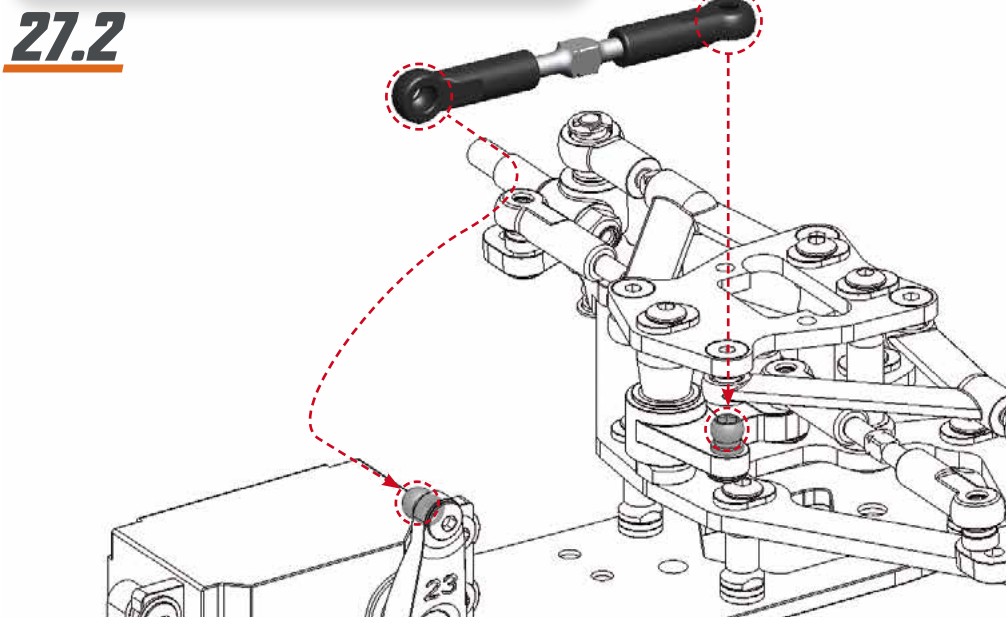
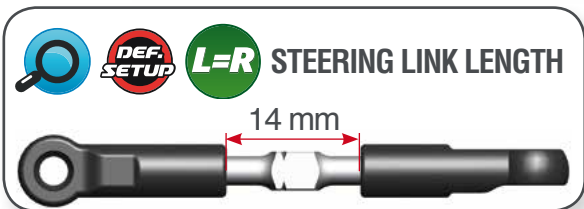
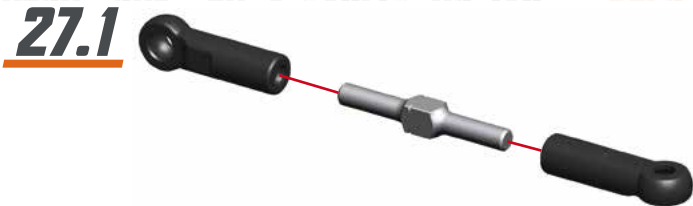

FORWARD SERVO CONFIGURATION **OPTIONAL**

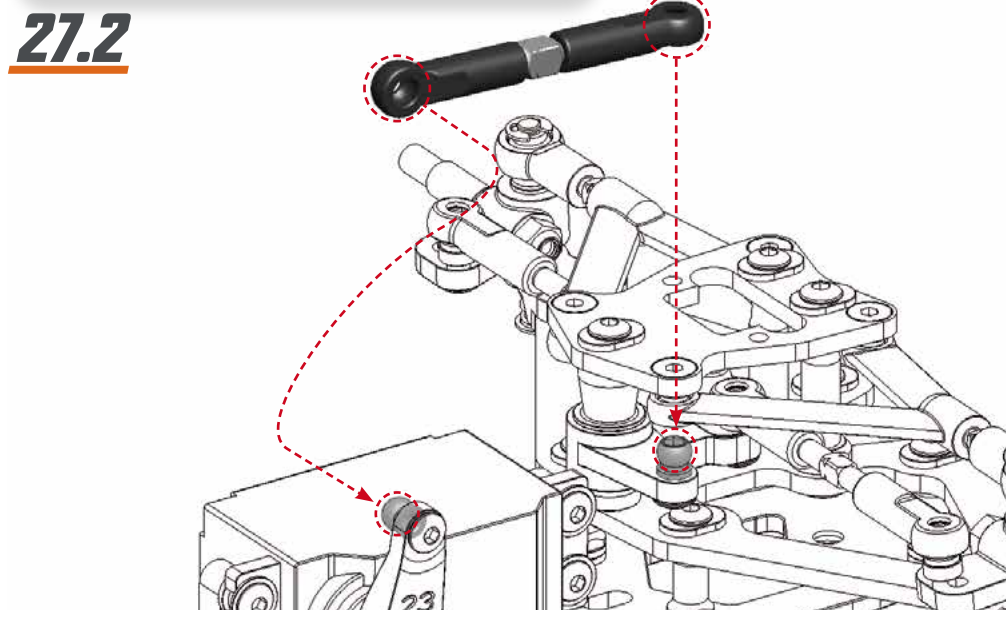
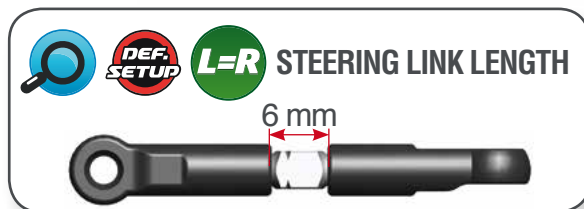
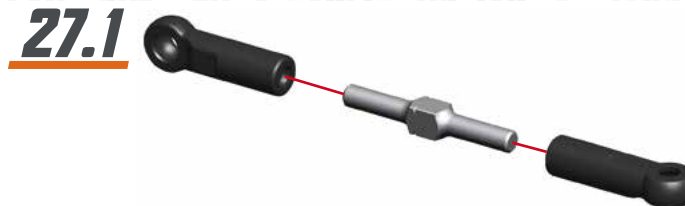

STEP 28

REARWARD BATTERY CONFIGURATION *DEFAULT*

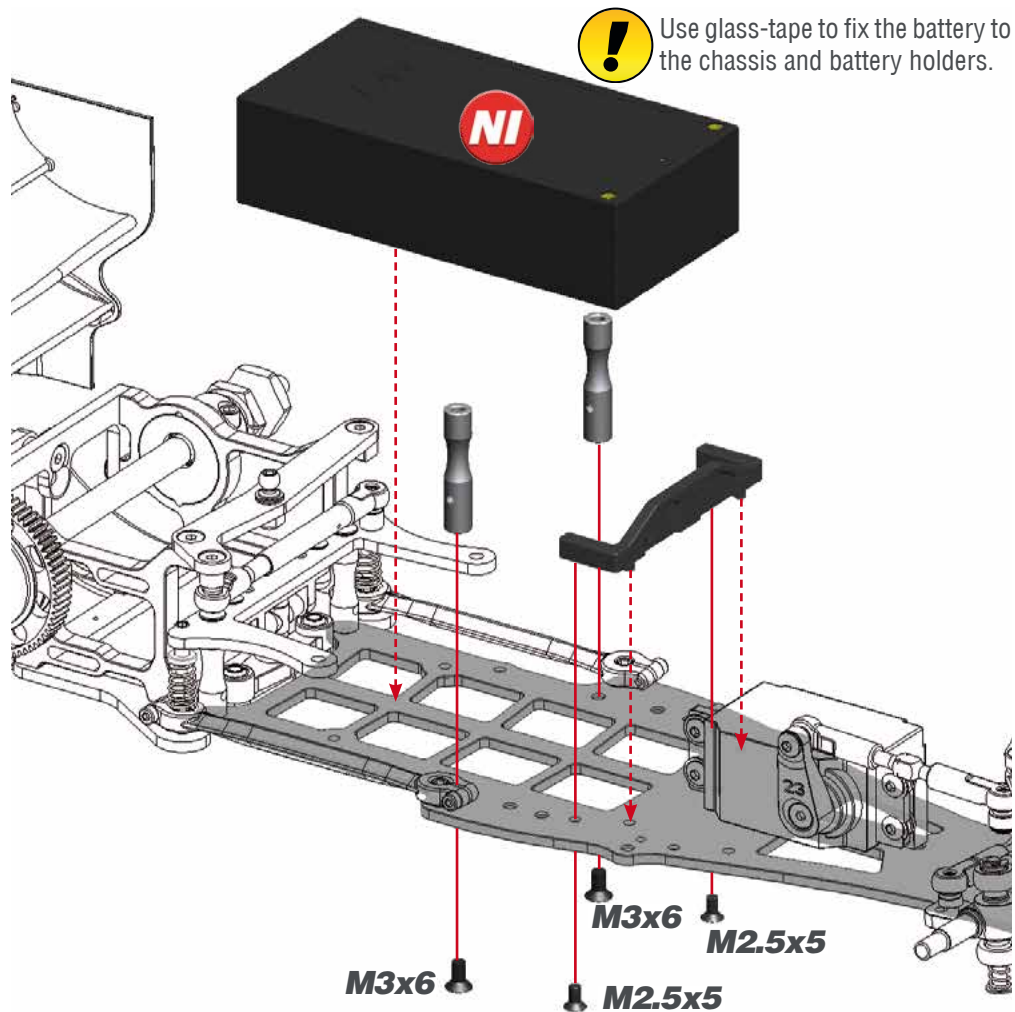

FORWARD BATTERY CONFIGURATION *OPTIONAL*

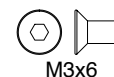
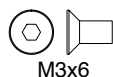
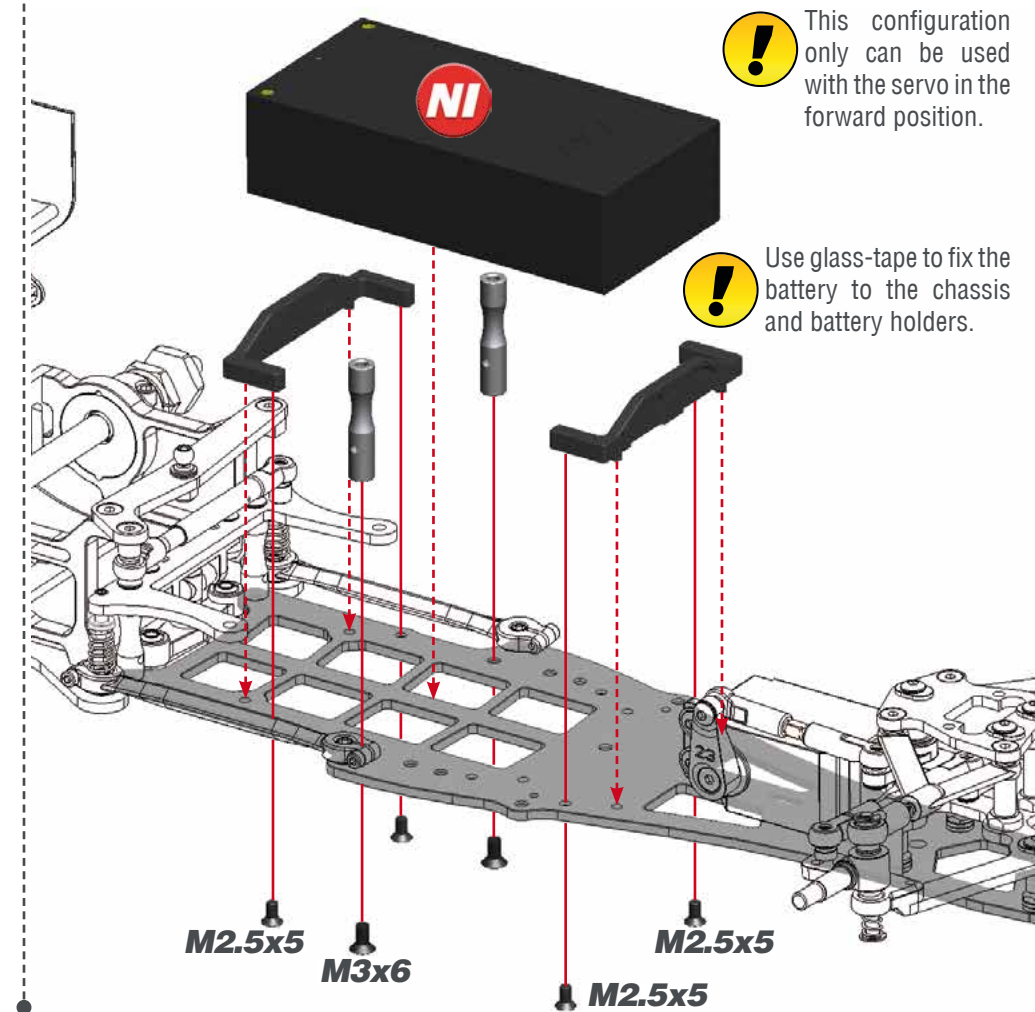

STEP 29

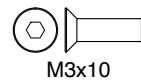
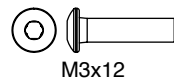
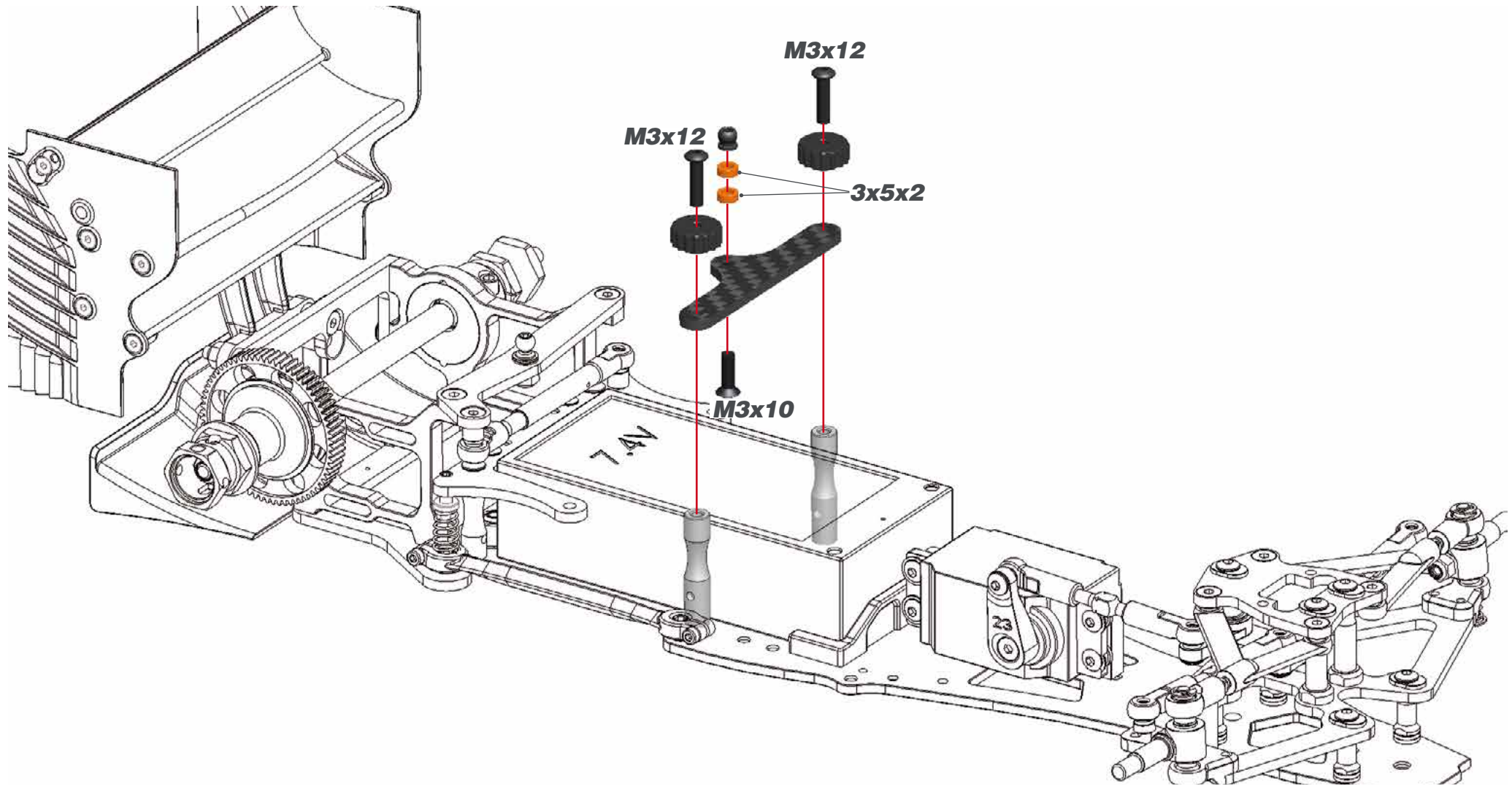

STEP 30 SHOCK BAG

30.1

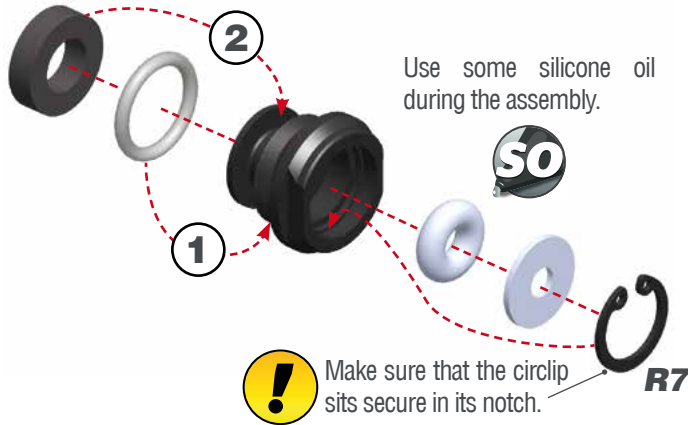

30.2

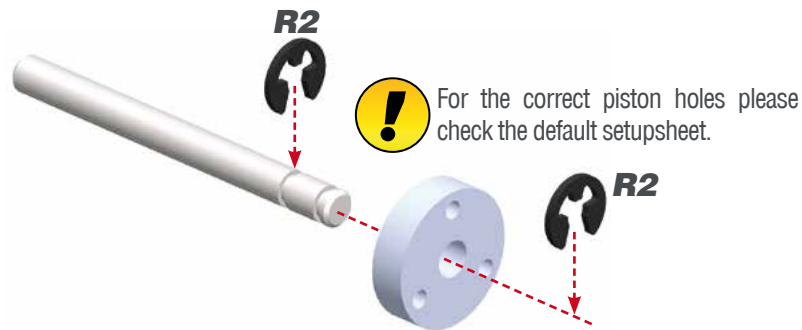

STEP 31

31.1

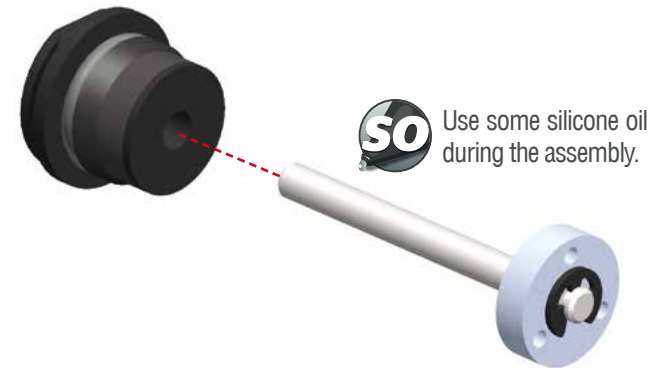

31.2

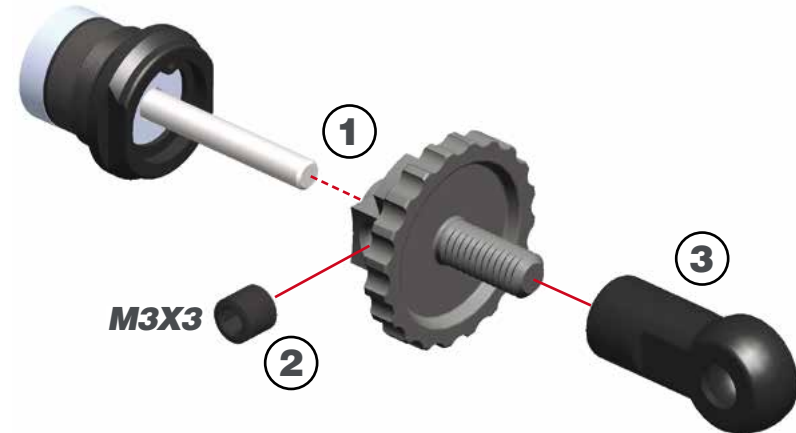

STEP 32

32.1

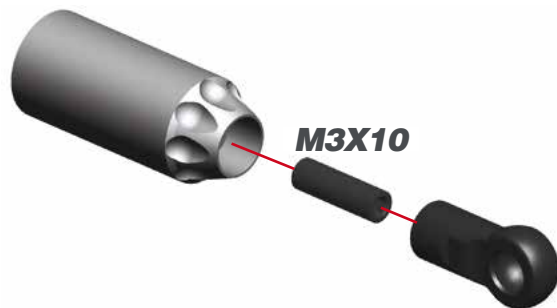

M3X10

32.2

1) Fill the shock body with shock absorber oil. Check the oil CST value in the setup sheet.

2) Bleeding: Let the oil settle and allow the air to escape.



STEP 33

Close the shock slowly.

Important: do not crossthread! Oil will overflow through the built-in bleed channel.

Tighten carefully until the bottom half sits against the shock body.

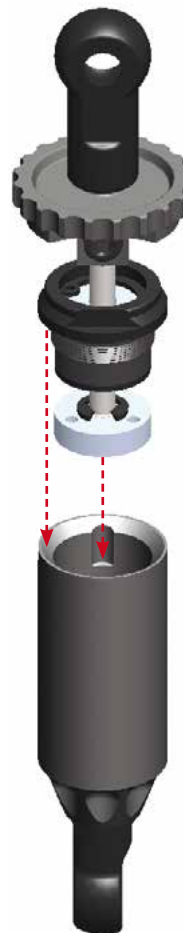

STEP 34

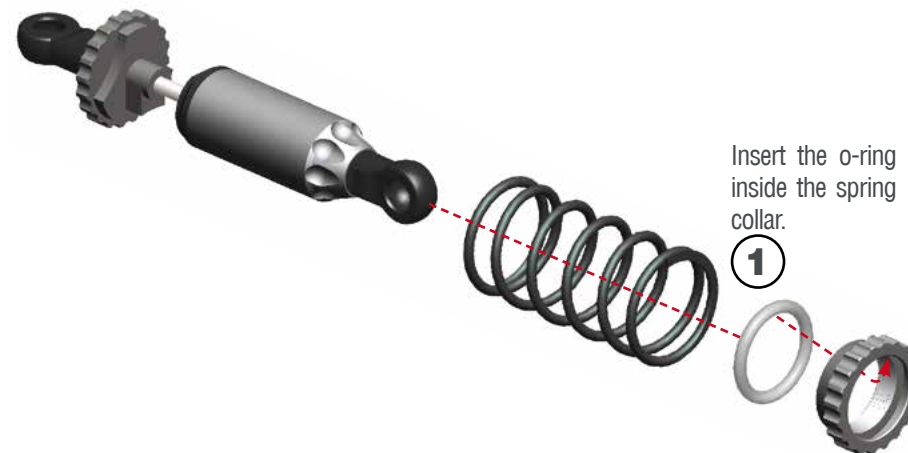

Insert the o-ring inside the spring collar.

1

STEP 35

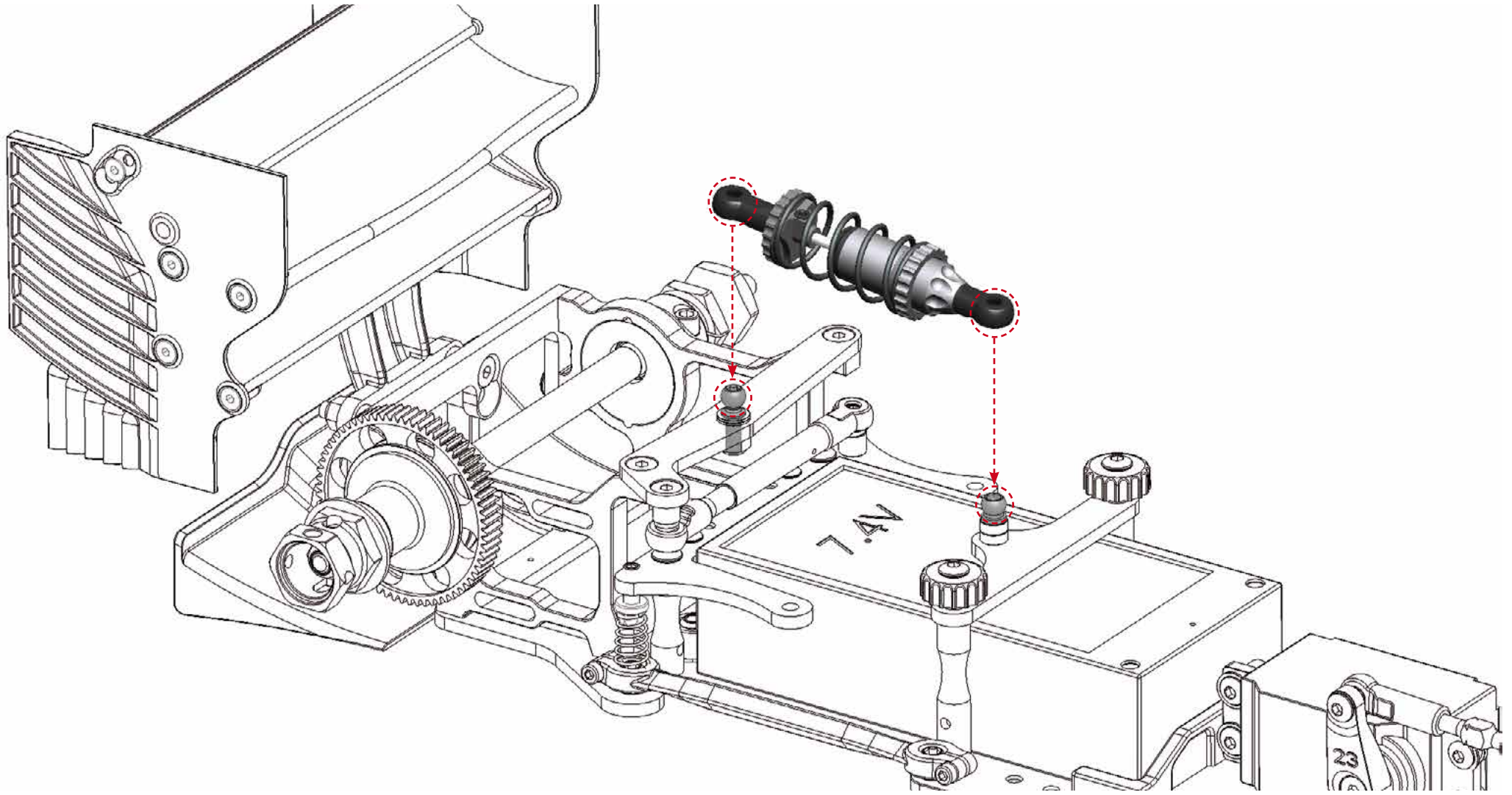

STEP 36 BAG 8

36.1

! The weights are used to compensate the weight of the ESC and equilibrate the chassis weight. They must be assembled on the opposite side of the ESC.

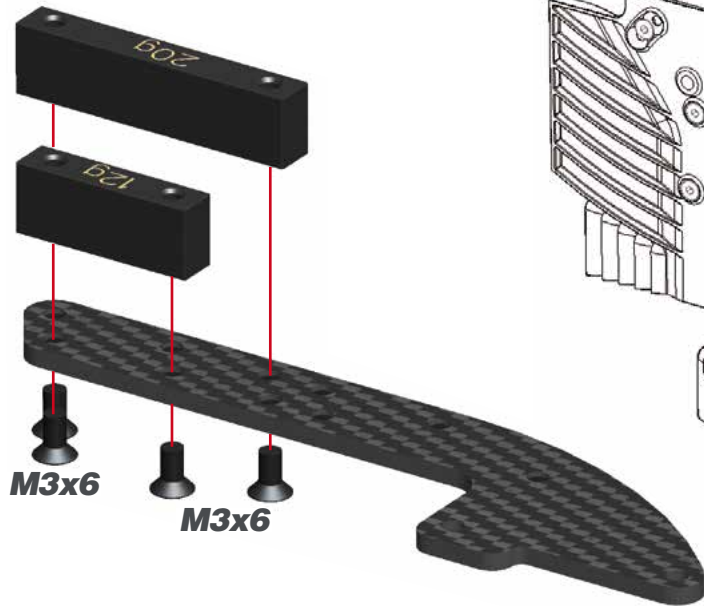

36.2

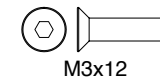
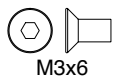
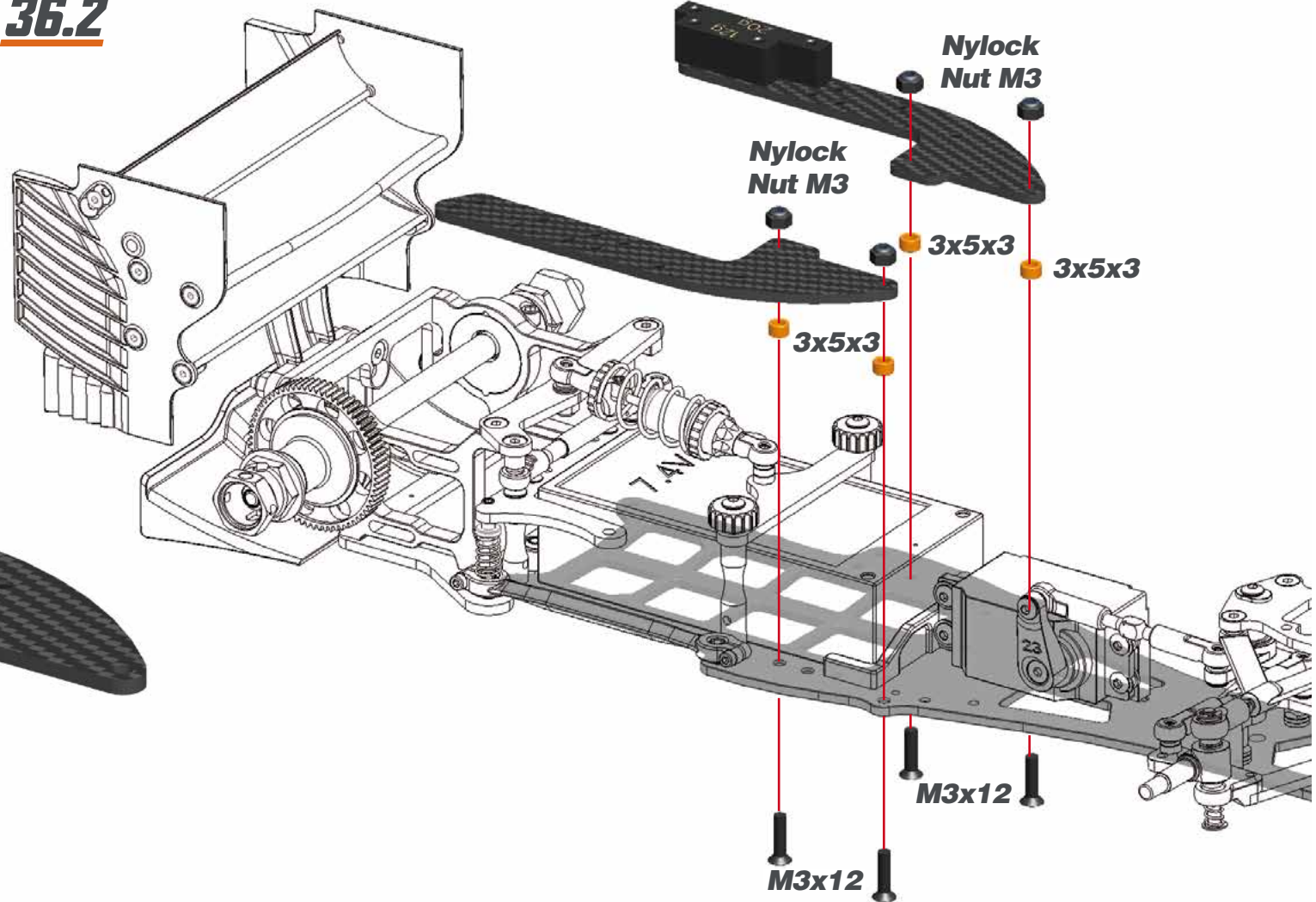

STEP 37

! Use double sided tape to mount the ESC and RX to the chassis.

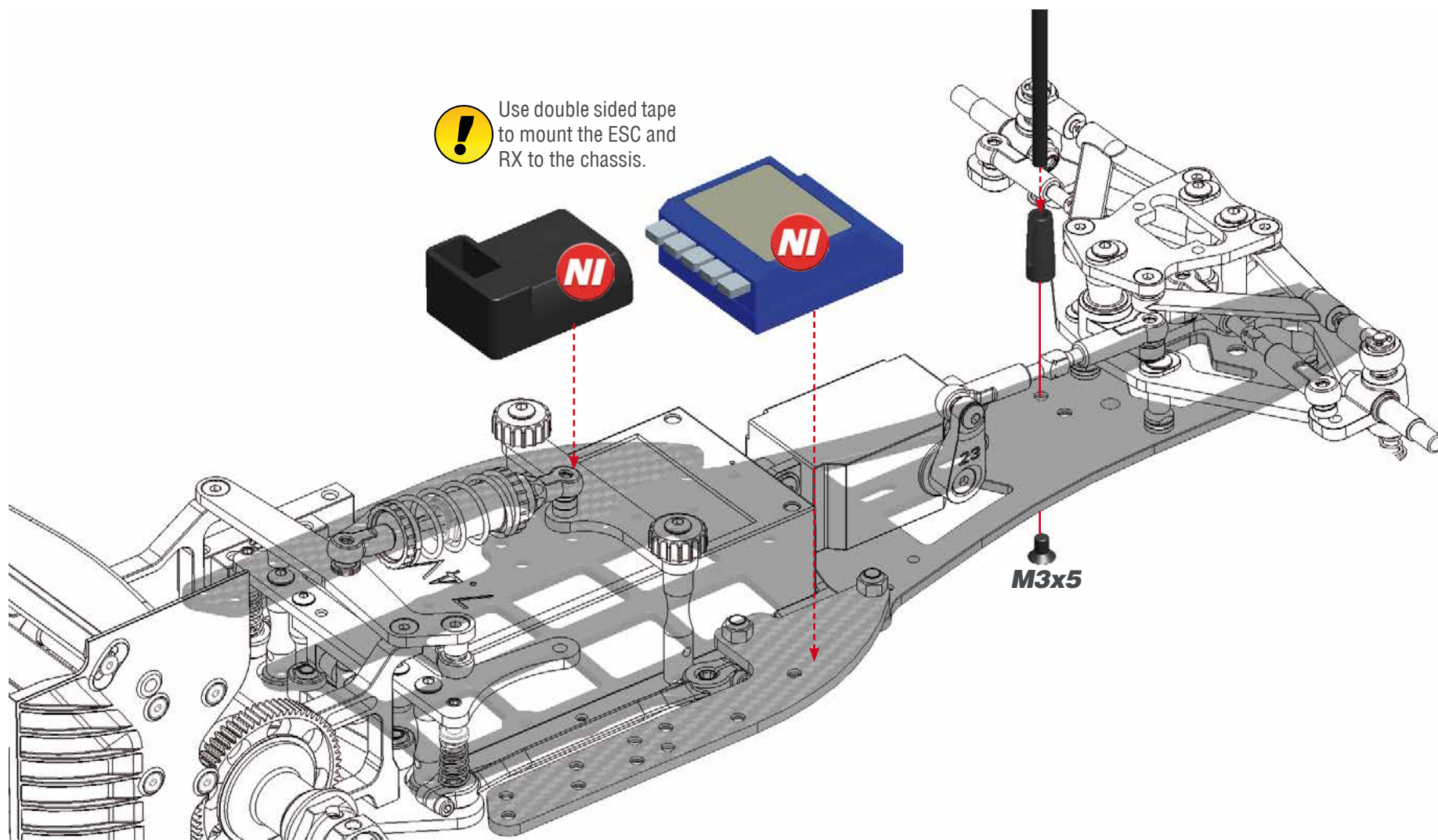
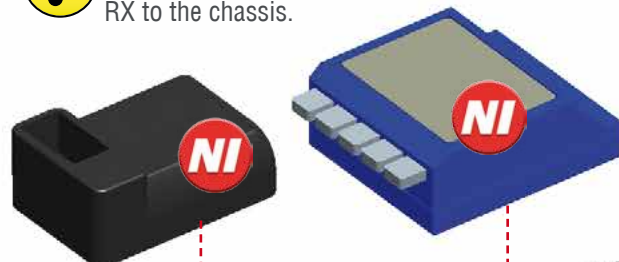

M3x5



STEP 38



Pinion is not included in the kit. Assemble the proper pinion for your set-up.

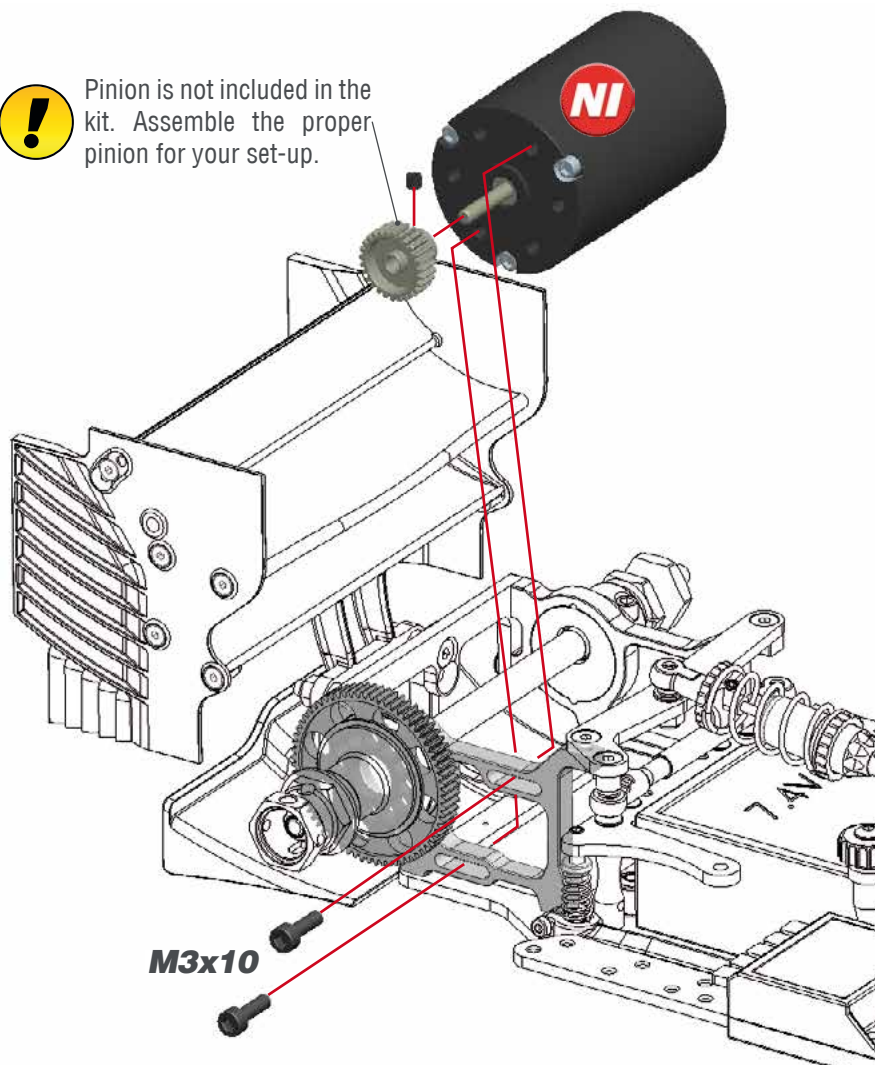

M3x10

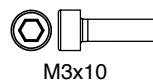

STEP 39

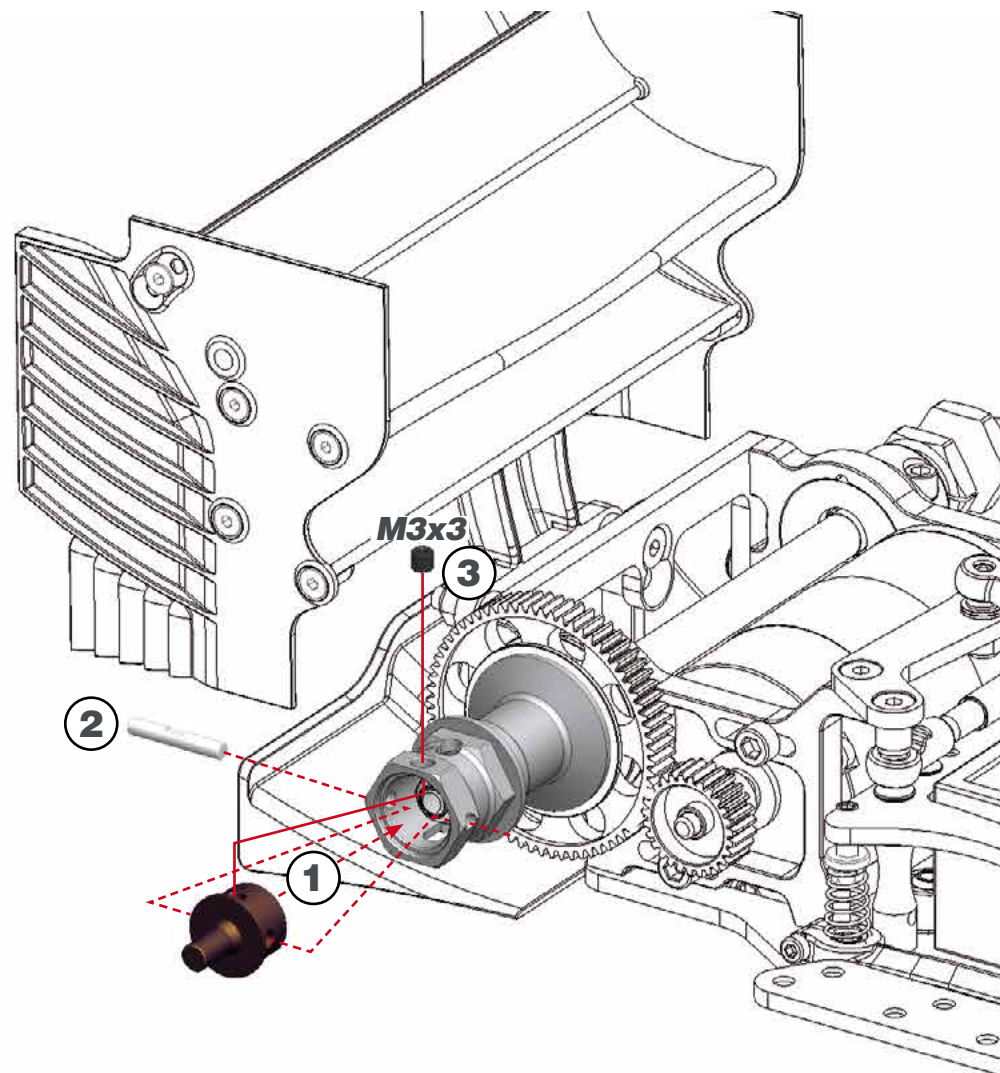

M3x3



STEP 40 **BAG 8**

FRONT WING ASSEMBLY *DEFAULT*

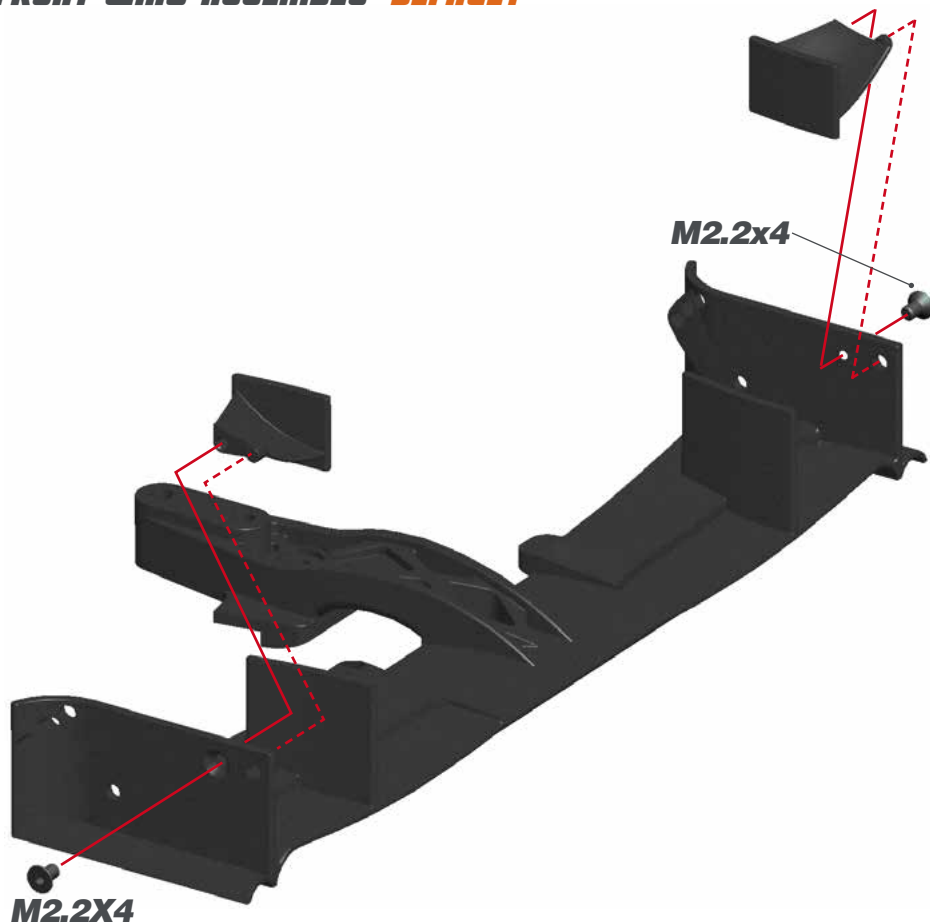

M2.2x4

FRONT WING BIG FLAPS ASSEMBLY *OPTIONAL*



The front big flaps create a big amount of downforce. It is recommended to don't assemble them as default and use them when more steering is needed. Also it is possible to cut them to adjust the amount of downforce created.

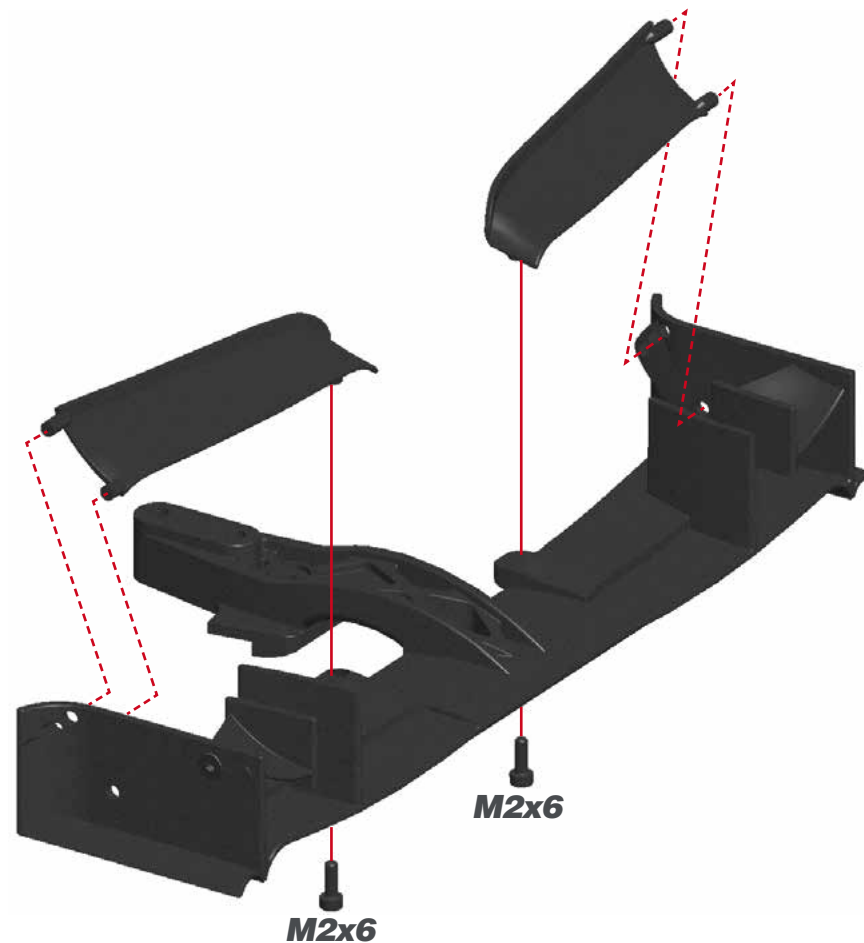

M2x6

STEP 41

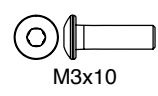
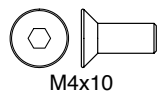
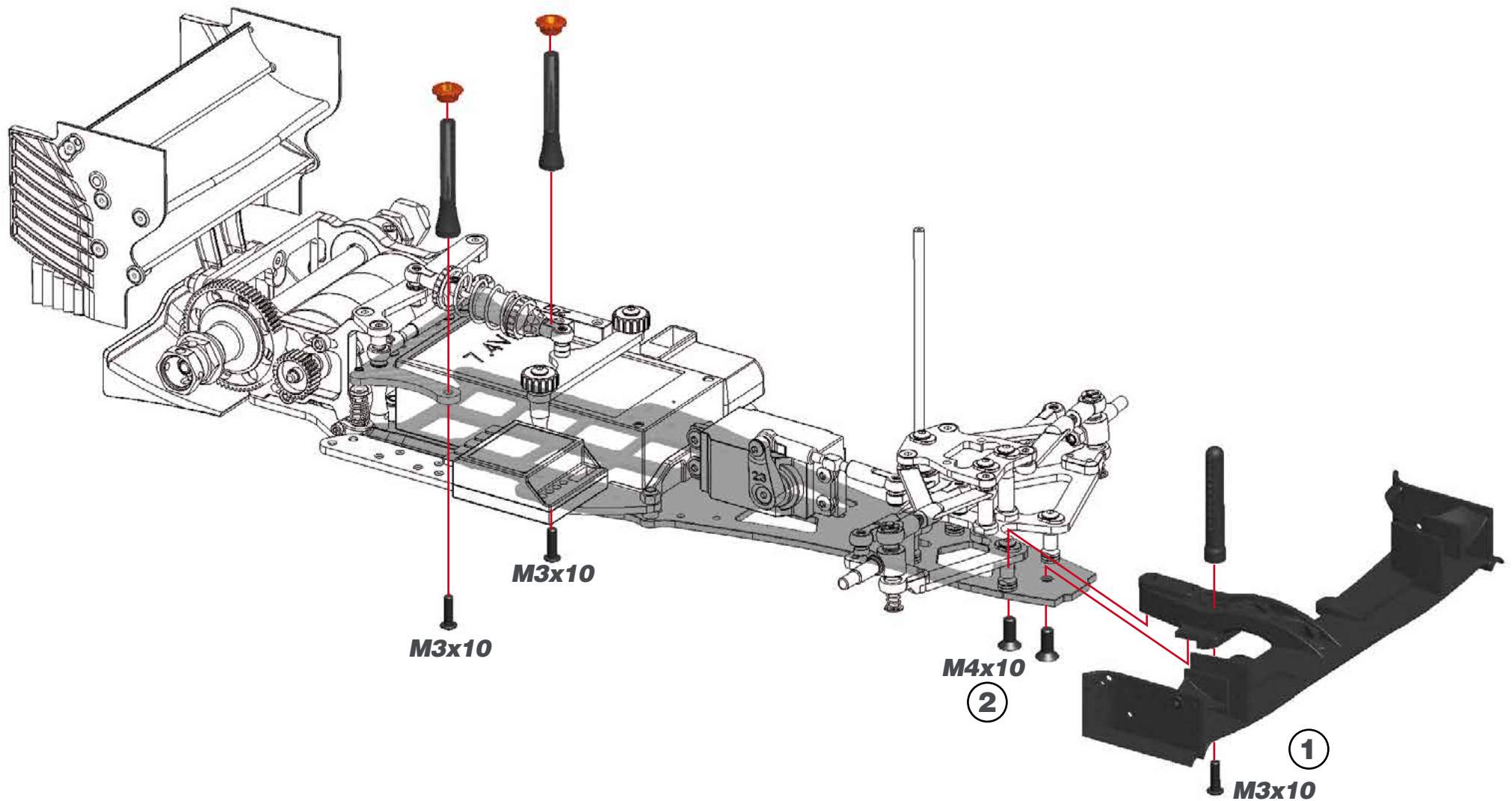

STEP 42

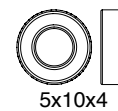
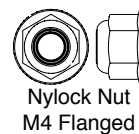
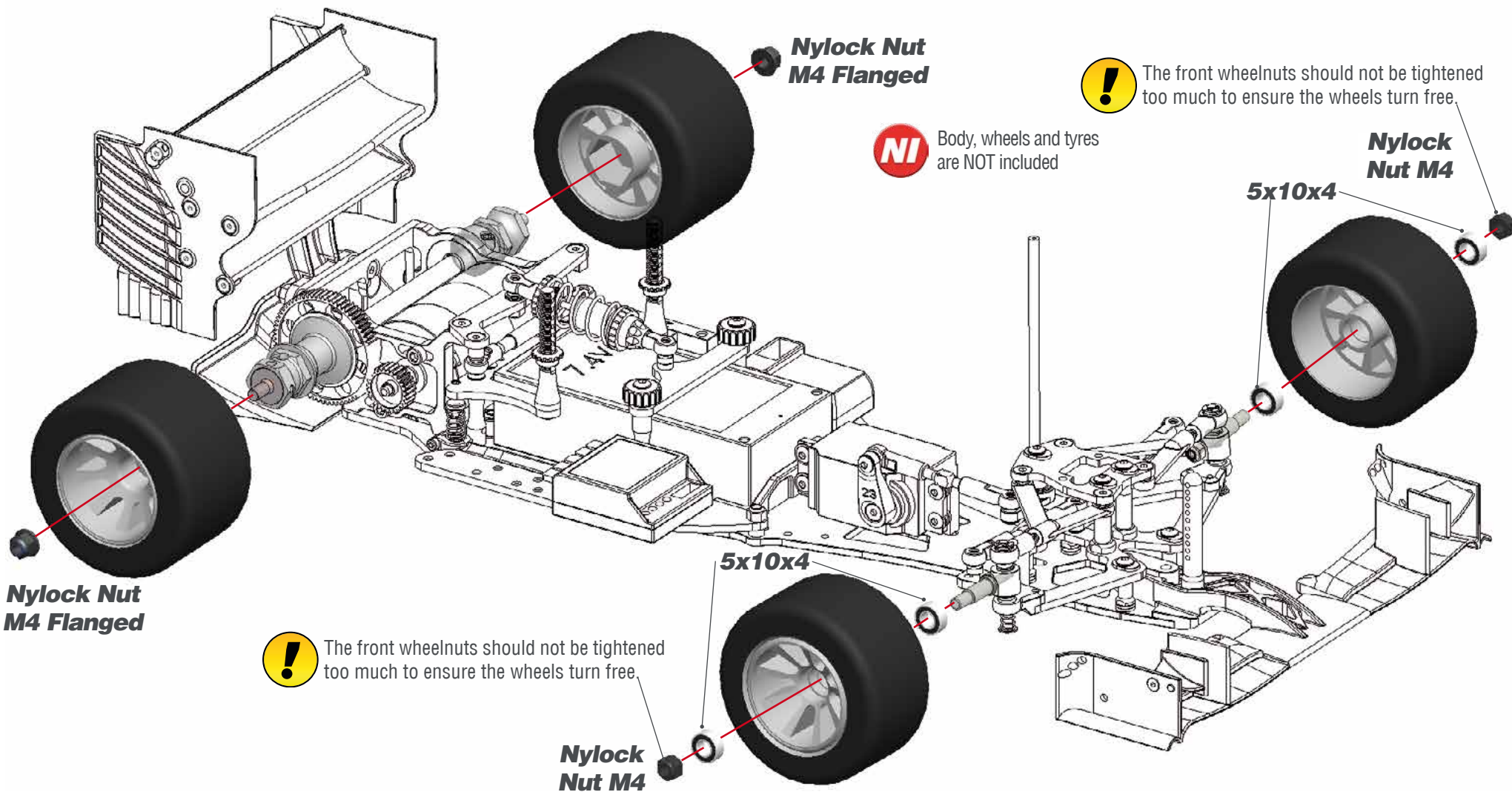

INDEX

<i>FRONT EXPLODED VIEW</i>	<i>32</i>
<i>BALL DIFF EXPLODED VIEW</i>	<i>33</i>
<i>REAR EXPLODED VIEW</i>	<i>34</i>
<i>SHOCK EXPLODED VIEW</i>	<i>35</i>
<i>CENTER EXPLODED VIEW</i>	<i>36</i>
<i>FINAL EXPLODED VIEW</i>	<i>37</i>
<i>TEAM SERPENT NETWORK</i>	<i>38</i>

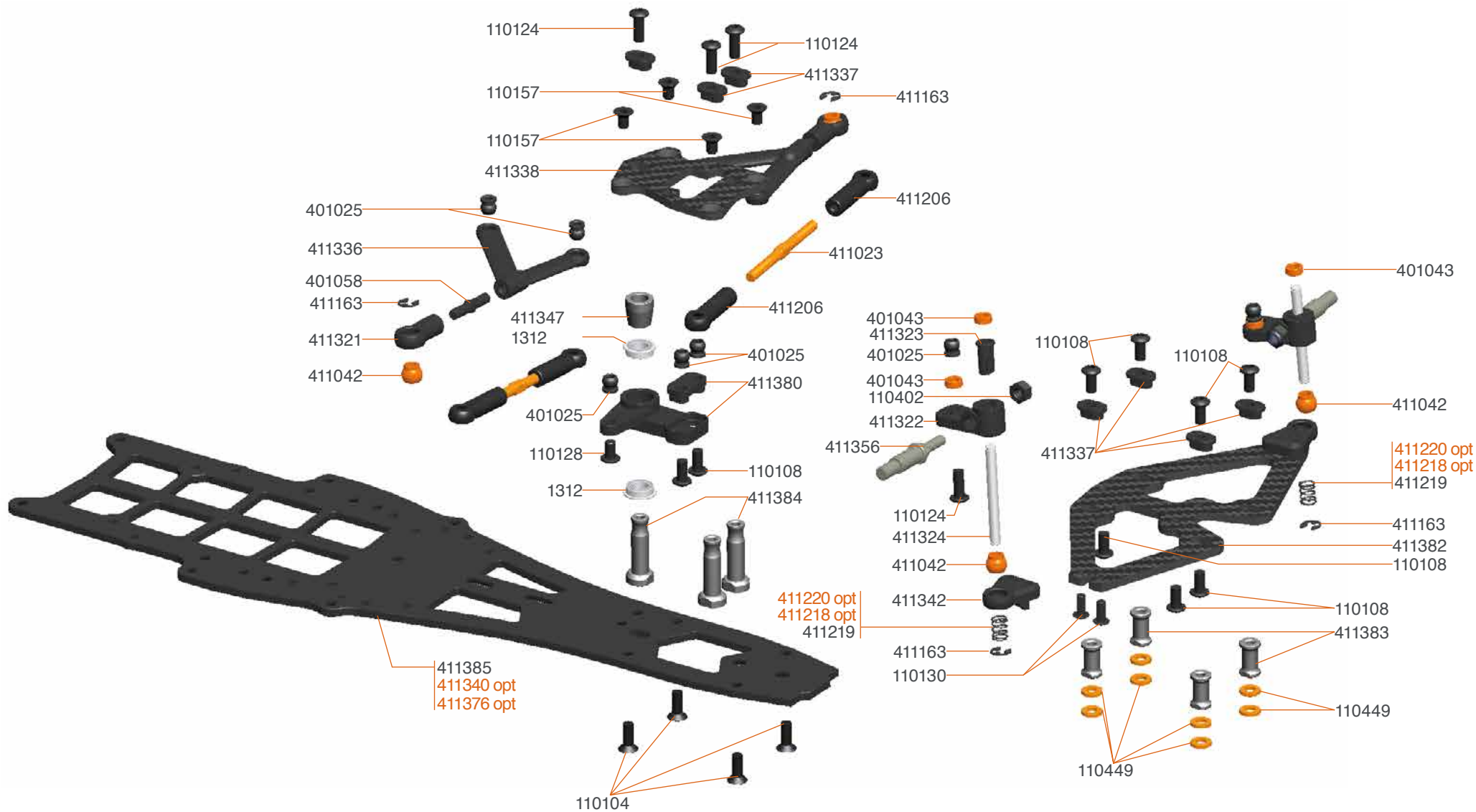

- 411218 Front spring 22lbs S120L (2)
- 411220 Front spring 26lbs S120L (2)
- 411340 Chassis carbon F110 SF2
- 411376 Chassis SWB carbon F110 SF2

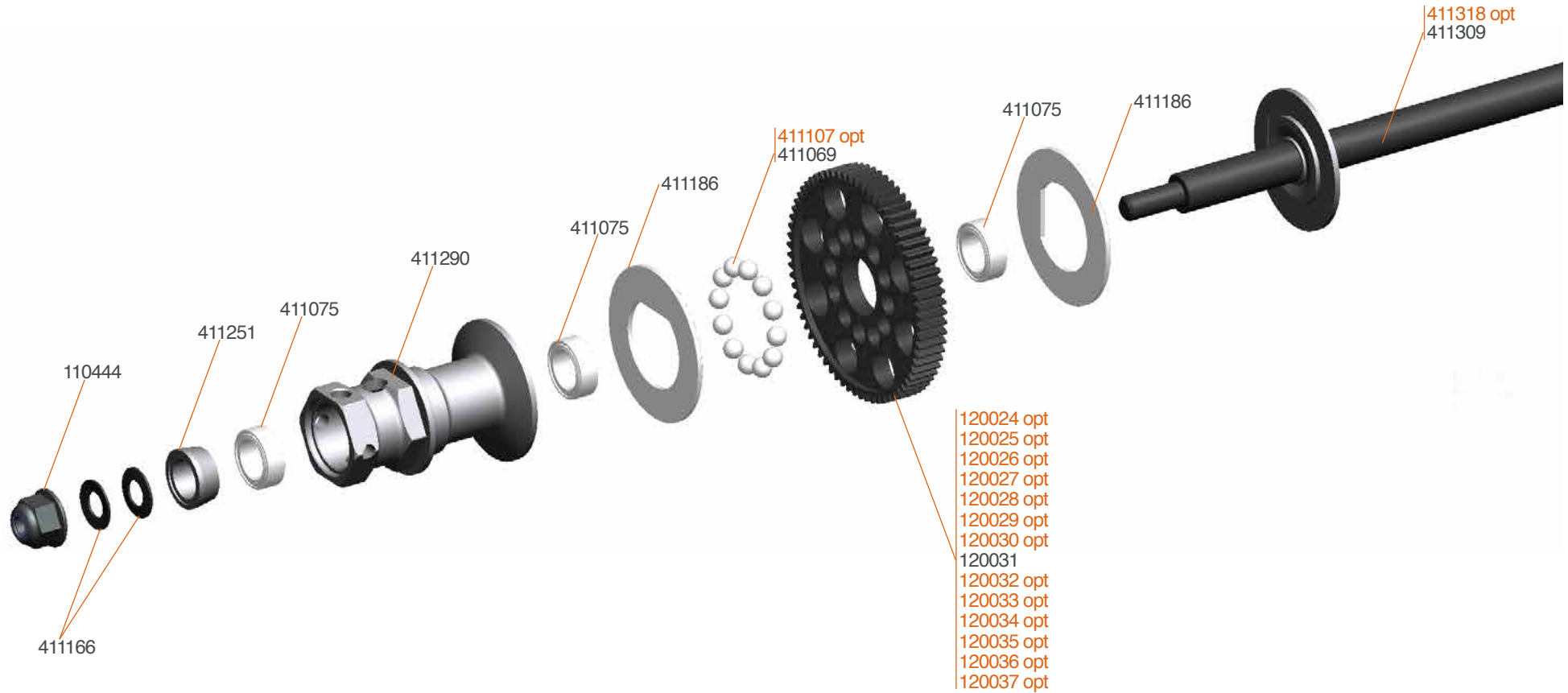

120024 Spur diff gear 64P/86T
120025 Spur diff gear 64P/90T
120026 Spur diff gear 64P/94T
120027 Spur diff gear 64P/98T

120028 Spur diff gear 64P/102T
120029 Spur diff gear 64P/106T
120030 Spur diff gear 64P/110T
120032 Spur diff gear 48P/72T

120033 Spur diff gear 48P/74T
120034 Spur diff gear 48P/76T
120035 Spur diff gear 48P/80T
120036 Spur diff gear 48P/84T

120037 Spur diff gear 48P/88T
411107 Diff balls. 1/8 ceramic (12)
411318 Rear axle F110 steel

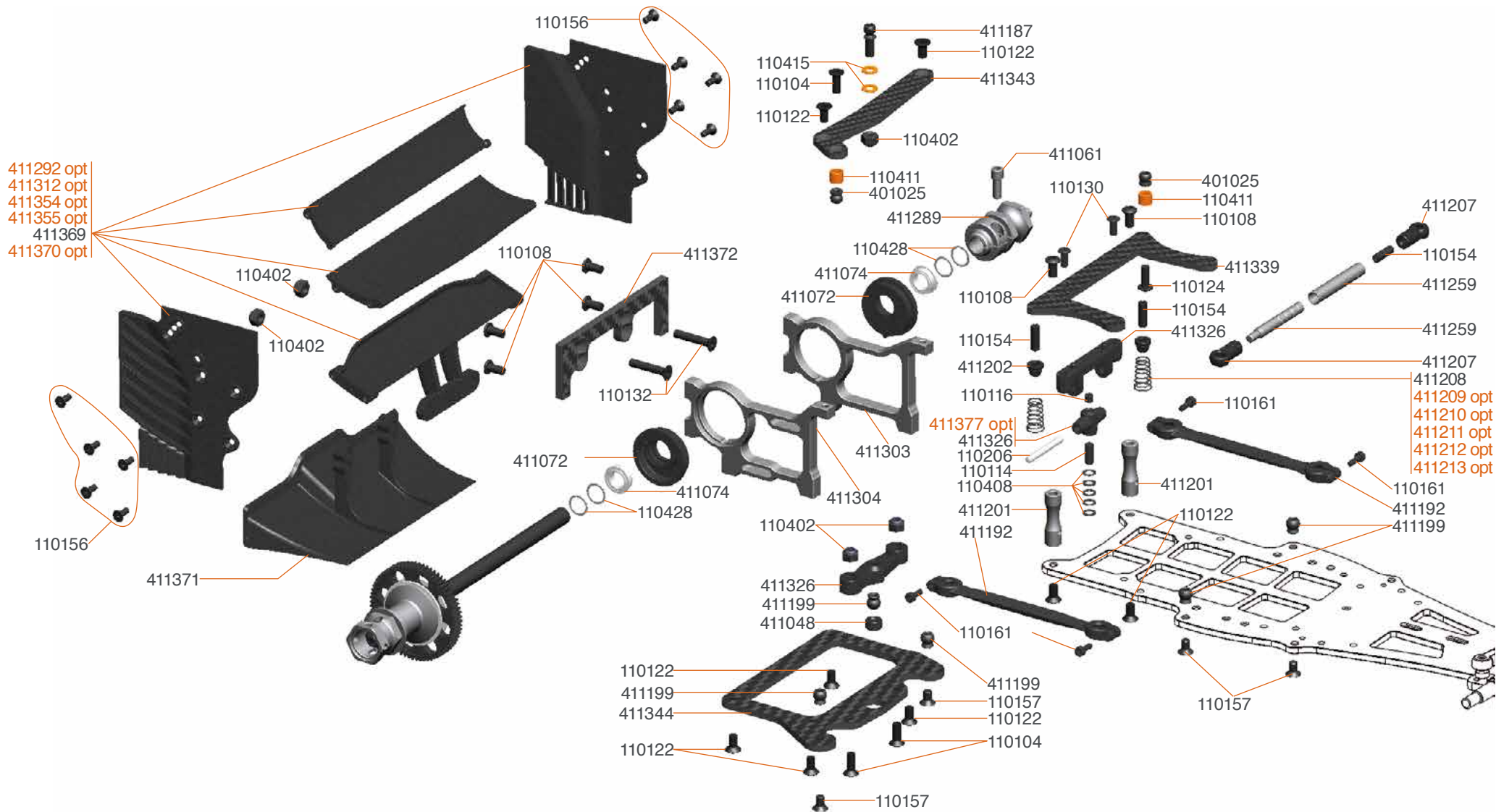

411292 Rear wing F110 black H DF
411312 Rear wing F110 white H DF
411354 Rear wing F110 black L DF
411355 Rear wing F110 white L DF

411370 Rear wing F110 white M DF
411209 Side spring 5,0lbs S120L (2)
411210 Side spring 5,5lbs S120L (2)
411211 Side spring 6,0lbs S120L (2)

411212 Side spring 6,5lbs S120L (2)
411213 Side spring 7,0lbs S120L (2)
411377 Center pivot alu

411120 Shock-absorber-set



411120 Shock-absorber-set
 411366 Center spring 6.5lbs
 411368 Center spring 10 lbs
 411214 Center spring 12lbs S120L

411215 Center spring 14lbs S120L
 411216 Center spring 16lbs S120L
 411217 Center spring 18lbs S120L

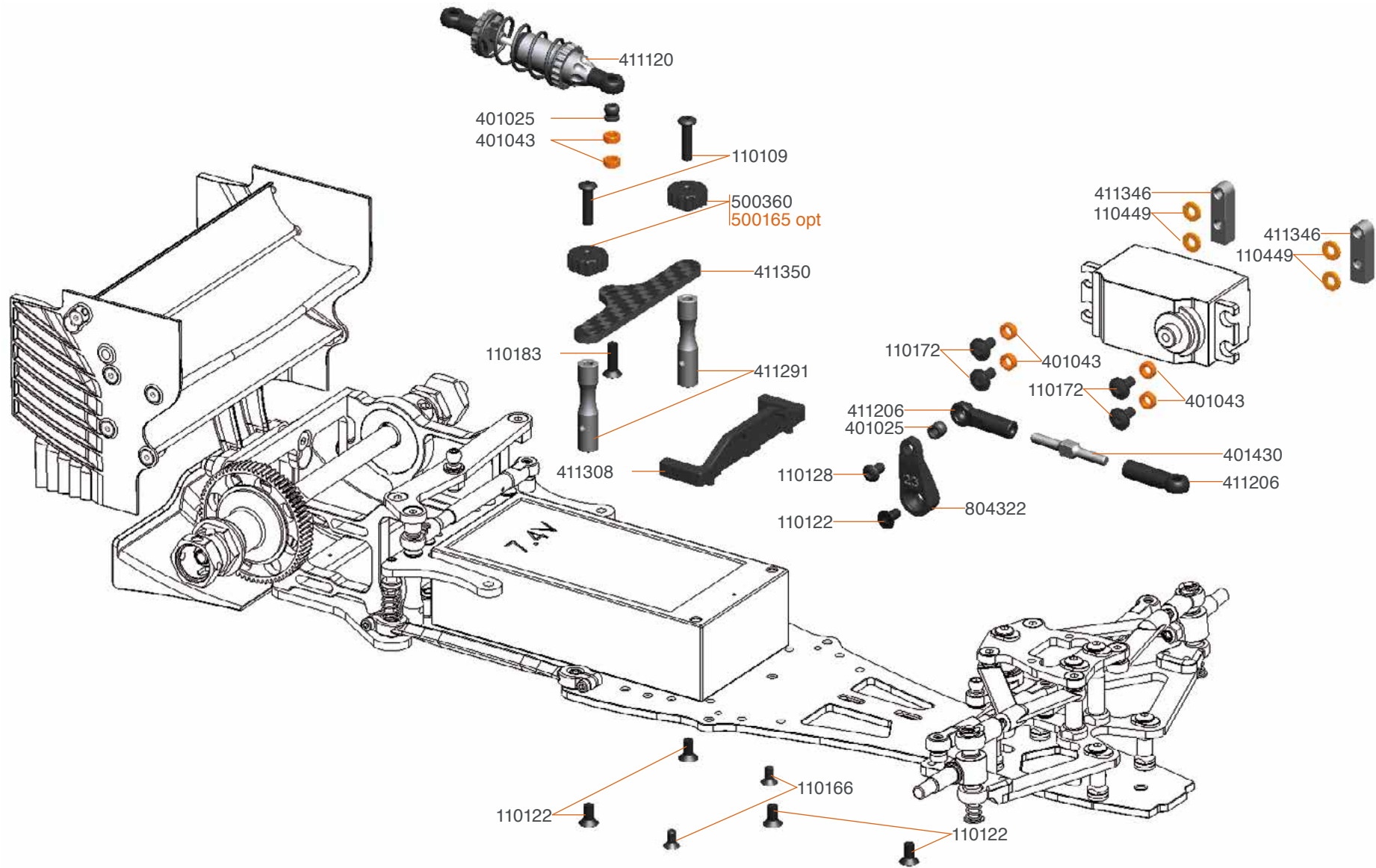

500165 Battery plate nut (4) SRX2



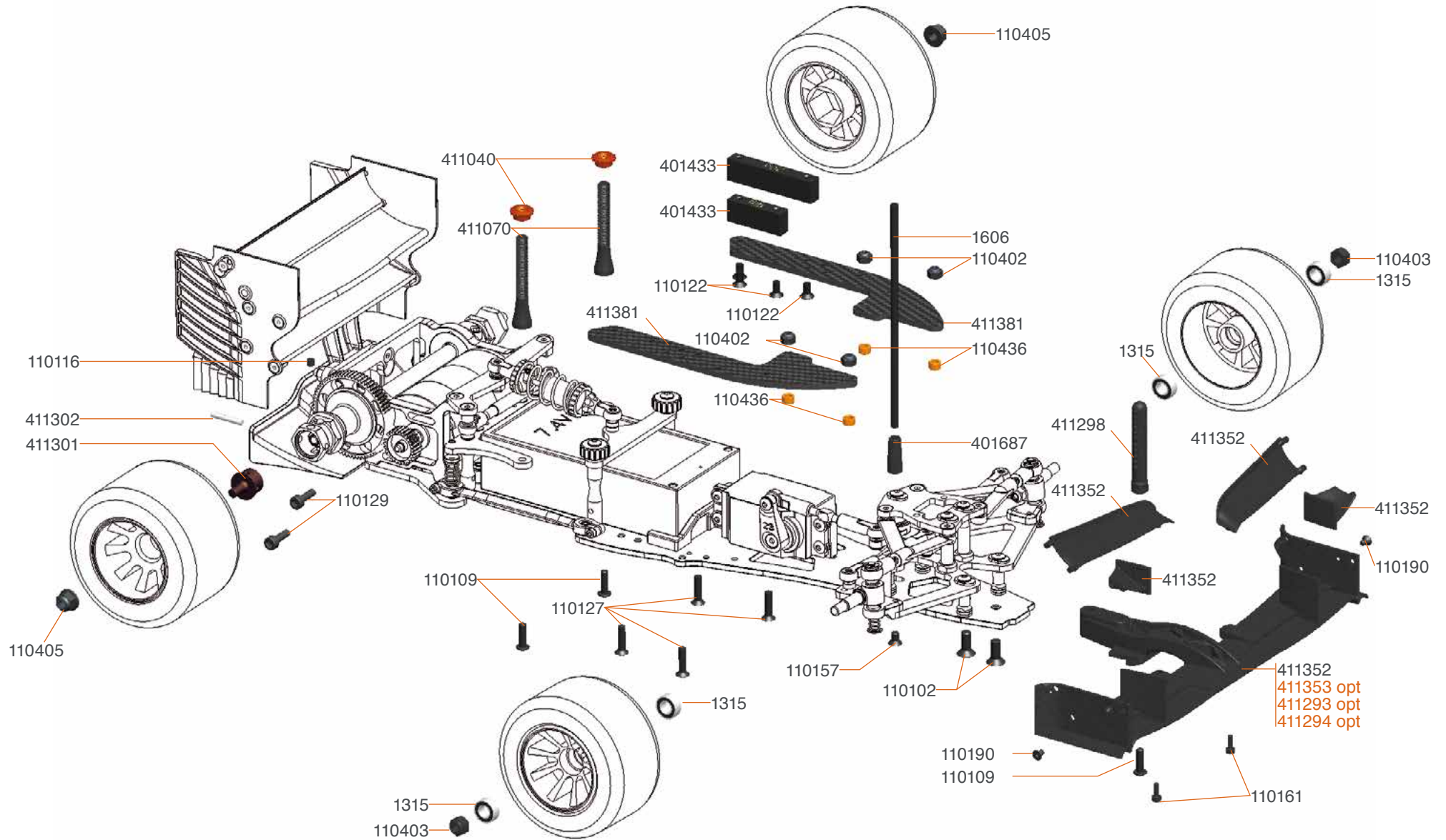

- 411293 Front bumper F110
- 411294 Front wing F110 (big+small)
- 411353 Wing front white F110 SF2

TEAM SERPENT NETWORK

F110 SF3 SPARE PARTS www.serpent.com/410065/spares/



F110 SF3 OPTIONALS PARTS www.serpent.com/410065/Optionals/



SERPENT TOOLS www.serpent.com/product/Tools/



SERPENT MERCHANDISING www.serpent.com/product/Merchandising/



SERPENT WEBSITE AND BLOG

www.serpent.com
www.teamserpent.com
www.dragon-rc.com

SERPENT PROMO PAGES <http://promo.serpent.com>

SERPENT FACEBOOK GROUPS <http://promo.serpent.com/indexfb.htm>

SERPENT ADVANCED MANUALS <http://promo.serpent.com/sam/>

SERPENT SOCIAL MEDIA



www.facebook.com/SerpentMRC



www.youtube.com/user/SerpentMRC



www.twitter.com/SerpentMRC



www.plus.google.com/+SerpentModelcars/posts



www.weibo.com/teamserpent

F110 SF3



#80852 1 Manual F110 SF3