

Driver: \_\_\_\_\_  
 Date: \_\_\_\_\_  
 Meeting: \_\_\_\_\_  
 Best Time: \_\_\_\_\_

**Track Details:**

Indoor \_\_\_\_\_ Tight \_\_\_\_\_  
 Outdoor \_\_\_\_\_ Open \_\_\_\_\_

Carpet \_\_\_\_\_  
 Asphalt \_\_\_\_\_  
 Concrete \_\_\_\_\_  
 Other: \_\_\_\_\_

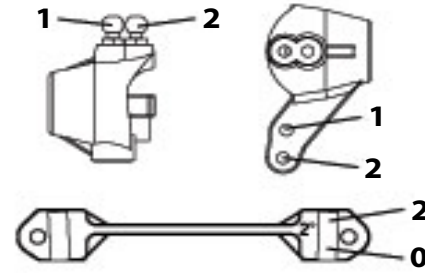
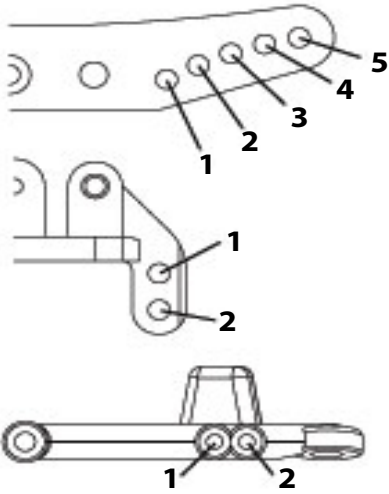

**Front Shocks**

Oil \_\_\_\_\_  
 Spring \_\_\_\_\_  
 Piston \_\_\_\_\_  
 Spacer \_\_\_\_\_  
 Length \_\_\_\_\_  
 Droop \_\_\_\_\_

Bracket Type \_\_\_\_\_ S1 \_\_\_\_\_ Carbon \_\_\_\_\_  
 Hub Carrier \_\_\_\_\_ plastic \_\_\_\_\_ alloy- \_\_\_\_\_ high / low \_\_\_\_\_  
 Anti-Roll Bar \_\_\_\_\_  
 Castor \_\_\_\_\_ degrees \_\_\_\_\_  
 Toe-In/Outboard \_\_\_\_\_ degrees \_\_\_\_\_  
 Ride Height \_\_\_\_\_ mm \_\_\_\_\_  
 Camber \_\_\_\_\_ degrees \_\_\_\_\_  
 Lower Wishbone \_\_\_\_\_ forward \_\_\_\_\_ rear \_\_\_\_\_  
 Front Driveshafts \_\_\_\_\_ plastic \_\_\_\_\_ steel \_\_\_\_\_

Notes:

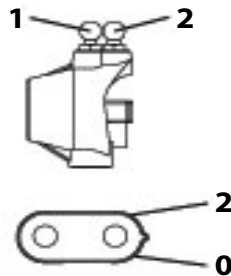
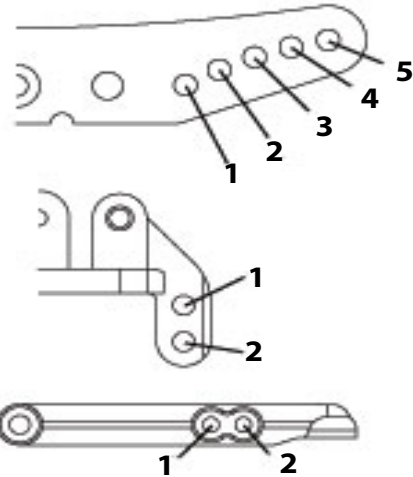

**Rear Shocks**

Oil \_\_\_\_\_  
 Spring \_\_\_\_\_  
 Piston \_\_\_\_\_  
 Spacer \_\_\_\_\_  
 Length \_\_\_\_\_  
 Droop \_\_\_\_\_

Bracket Type \_\_\_\_\_ S1 \_\_\_\_\_ Carbon \_\_\_\_\_  
 Hub Carrier \_\_\_\_\_ plastic \_\_\_\_\_ alloy- \_\_\_\_\_ high / low \_\_\_\_\_  
 Anti-Roll Bar \_\_\_\_\_  
 Anti/Pro Squat \_\_\_\_\_  
 Toe-In/Outboard \_\_\_\_\_ degrees \_\_\_\_\_  
 Ride Height \_\_\_\_\_ mm \_\_\_\_\_  
 Camber \_\_\_\_\_ degrees \_\_\_\_\_  
 Lower Wishbone \_\_\_\_\_ forward \_\_\_\_\_ middle \_\_\_\_\_ rear \_\_\_\_\_  
 Rear Driveshafts \_\_\_\_\_ plastic \_\_\_\_\_ steel \_\_\_\_\_

Notes:

Motor \_\_\_\_\_  
 Gearing \_\_\_\_\_ pinion \_\_\_\_\_ spur \_\_\_\_\_  
 Pulley Size \_\_\_\_\_ 17 tooth \_\_\_\_\_ 20 tooth \_\_\_\_\_  
 Bodyshell \_\_\_\_\_  
 Oneway Diff \_\_\_\_\_ yes \_\_\_\_\_ no \_\_\_\_\_  
 Front Tires \_\_\_\_\_  
 Rear Tires \_\_\_\_\_  
 Front Inserts \_\_\_\_\_  
 Rear Inserts \_\_\_\_\_  
 Tire Additive \_\_\_\_\_ yes \_\_\_\_\_ no \_\_\_\_\_ Brand: \_\_\_\_\_  
 Chassis \_\_\_\_\_ S1 \_\_\_\_\_ carbon \_\_\_\_\_ Top Deck \_\_\_\_\_ S1 \_\_\_\_\_ carbon \_\_\_\_\_  
 ESC \_\_\_\_\_  
 Battery \_\_\_\_\_  
 Receiver \_\_\_\_\_  
 Servo \_\_\_\_\_

**Driver Comments:**

\_\_\_\_\_