

## DRIVER AND EVENT DETAILS

Name CHRIS ASHTON

Date MARCH 07

Event CARPET TEST DAY

Weather INDOOR

Result

## CHASSIS AND ELECTRICS

Chassis STD

Top Deck Flex  Standard  Stiff

Bodyshell P.F.MAZDA

Wing STD

E.S.C LRP SPHERE TC

Servo K.O

Receiver K.O

Number of Cells 4  5  6

Type of Cells SCHUMACHER IB4200 WC

## TRACK CONDITIONS

Grip Level High  Medium  Low

Track Type Tight  Open  Both

Surface Carpet  Tarmac  Wood

Venue Indoor  Outdoor

Track Condition Smooth  Bumpy

Track Temperature °C °F

## MOTOR AND GEARING

Type Brushed  Brushless

Motor LRP 4.5

Brush

Spring

Timing

Gear Pitch 48Dp  64Dp

Spur Size 89T

Pinion Size 18T



## DRIVER NOTES

1.00 mm Washer Against Hex.

## WHEELS, TYRES AND INSERTS

Wheels SCHUMACHER REVLITE

Tyres SOREX 28BM

Inserts SOREX BM

Tyre Additive LRP

Additive Time 30 MIN (R) 15 MIN (F)

Tyre Warmers Yes  No

## FRONT SETTINGS

Drive Diff  Spool  One-Way  Height High  Low

Servo Saver Yes  No

Toe In-Out In-board  Out-board  1° Toe-out

Screw Block Spacers Front 0.50 mm Rear 0.50 mm

Wishbone Quik-Klips Front 3.00 mm Rear 1.00 mm

Link Washers (Horizontal) 4.00 mm

Ride Height (Chassis to Floor) 5.00 mm

Droop (Chassis to Floor) 7.50 mm

Anti-roll Bar Yes  No  1.20  1.40  1.60

Castor 0°  2°  4°  6°

Camber Positive  Negative  1.50 DEG

Link Washers (Vertical) 1.00 mm

Inboard Pin Kick-up  Anti-dive  Horizontal

Pivot Block Spacers Front 0.50 mm Rear 0.50 mm

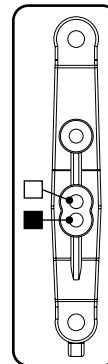
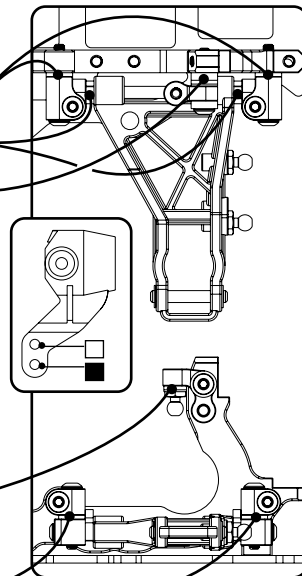

## Front Shocks

Oil 40WT

Springs BLUE

Piston Holes 2  3

length 61.50 mm

Rebound 30 %

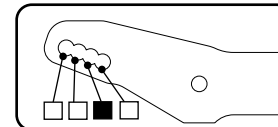

## Centre Track Rod

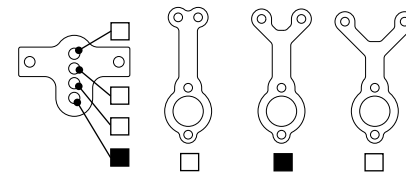

## REAR SETTINGS

Drive Height High  Low

Toe In In-board  3.20° Out-board  3.20°

Screw Block Spacers Front 1.50 mm Rear 1.00 mm

Wishbone Quik-Klips Front 2.00 mm Rear 2.00 mm

Link Washers (Horizontal) 4.00 mm

Ride Height (Chassis to Floor) 5.50 mm

Droop (Chassis to Floor) 9.00 mm

Anti-roll Bar Yes  No  1.20  1.40  1.60

Camber Positive  Negative  1.50 DEG

Link Washers (Vertical) 2.00 mm

Inboard Pin Pro-Squat  Anti-Squat  Horizontal

Pivot Block Spacers Front 1.00 mm Rear 1.00 mm

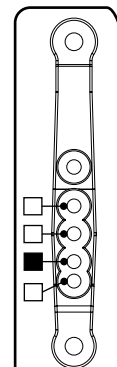
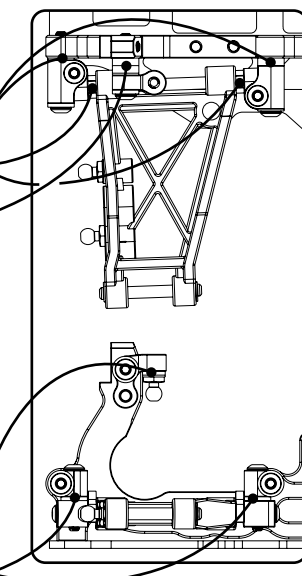

## Rear Shocks

Oil 35WT

Springs WHITE

Piston Holes 2  3

length 62.50 mm

Rebound 30 %

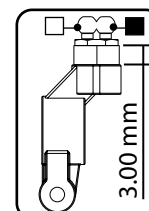

## Driver Notes

1.00mm Washer  
Against Hex.  
Rx Behind Cells

