

DRIVER AND EVENT DETAILS

Name

Date

Event

Weather

Result

TRACK CONDITIONS

Grip Level High Medium Low

Track Type Tight Open Both

Surface Carpet Tarmac Wood

Venue Indoor Outdoor

Track Condition Smooth Bumpy

Track Temperature °C °F



DRIVER NOTES

CHASSIS AND ELECTRICS

Chassis

Top Deck Flex Standard Stiff

Bodyshell

Wing

E.S.C.

Servo

Receiver

Number of Cells 4 5 6

Type of Cells

MOTOR AND GEARING

Type Brushed Brushless

Motor

Brush

Spring

Timing

Gear Pitch 48Dp 64Dp

Spur Size

Pinion Size

WHEELS, TYRES AND INSERTS

Wheels

Tyres

Inserts

Tyre Additive

Additive Time MIN (R) MIN (F)

Tyre Warmers Yes No

FRONT SETTINGS

Drive Diff Spool One-Way Height High Low

Servo Saver Yes No

Toe In-Out In-board Out-board ° Toe-out

Screw Block Spacers Front mm Rear mm

Wishbone Quik-Klips Front mm Rear mm

Link Washers (Horizontal) mm

Ride Height (Chassis to Floor) mm

Droop (Chassis to Floor) mm

Anti-roll Bar Yes No 1.20 1.40 1.60

Castor 0° 2° 4° 6°

Camber Positive Negative Deg

Link Washers (Vertical) mm

Inboard Pin Kick-up Anti-dive Horizontal

Pivot Block Spacers Front mm Rear mm

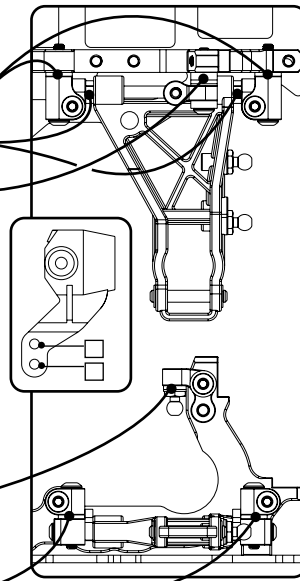

Front Shocks

Oil WT

Springs

Piston Holes 2 3

length

Rebound %

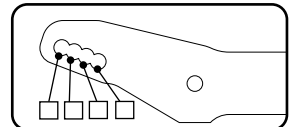
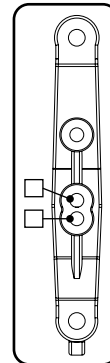

Centre Track Rod

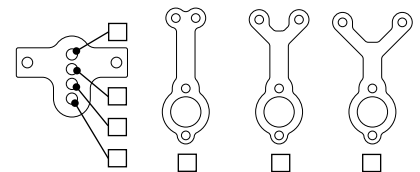

REAR SETTINGS

Drive Height High Low

Toe In In-board Out-board °

Screw Block Spacers Front mm Rear mm

Wishbone Quik-Klips Front mm Rear mm

Link Washers (Horizontal) mm

Ride Height (Chassis to Floor) 5.2 mm

Droop (Chassis to Floor) 25 mm

Anti-roll Bar Yes No 1.20 1.40 1.60

Camber Positive Negative Deg

Link Washers (Vertical) mm

Inboard Pin Pro-Squat Anti-Squat Horizontal

Pivot Block Spacers Front mm Rear mm

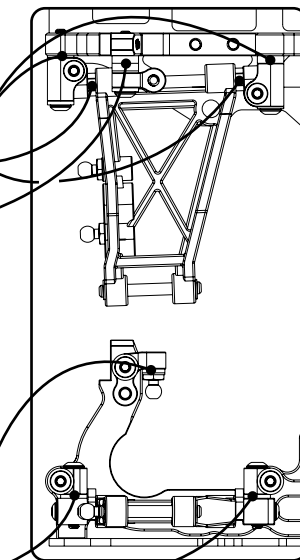

Rear Shocks

Oil WT

Springs

Piston Holes 2 3

length

Rebound %

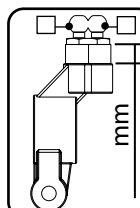
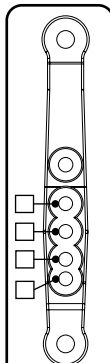

Driver Notes

