

### DRIVER AND EVENT DETAILS

Name

Date

Event

Weather

Result

### TRACK CONDITIONS

Grip Level  High  Medium  Low

Track Type  Tight  Open  Both

Surface  Carpet  Tarmac  Wood

Venue  Indoor  Outdoor

Track Condition  Smooth  Bumpy

Track Temperature  °C  °F



### DRIVER NOTES

### CHASSIS AND ELECTRICS

Chassis

Top Deck  Flex  Standard  Stiff

Bodyshell

Wing

E.S.C.

Servo

Receiver

Number of Cells  4  5  6

Type of Cells

### MOTOR AND GEARING

Type  Brushed  Brushless

Motor

Brush

Spring

Timing

Gear Pitch  48Dp  64Dp

Spur Size

Pinion Size

### WHEELS, TYRES AND INSERTS

Wheels

Tyres

Inserts

Tyre Additive

Additive Time  MIN (R)  MIN (F)

Tyre Warmers  Yes  No

### FRONT SETTINGS

Drive  Diff  Spool  One-Way  Height  High  Low

Servo Saver  Yes  No

Toe In-Out  In-board  Out-board  ° Toe-out

Screw Block Spacers  Front 0,5 mm  Rear 0,5 mm

Wishbone Quik-Klips  Front 2,0 mm  Rear 2,0 mm

Link Washers (Horizontal)  3,0 mm

Ride Height (Chassis to Floor)  5,0 mm

Droop (Chassis to Floor)  4,0 mm

Anti-roll Bar  Yes  No  1,20  1,40  1,60

Castor  0°  2°  4°  6°

Camber  Positive  Negative  1,0 Deg

Link Washers (Vertical)  2,5 mm

Inboard Pin  Kick-up  Anti-dive  Horizontal

Pivot Block Spacers  Front 1,0 mm  Rear 1,0 mm

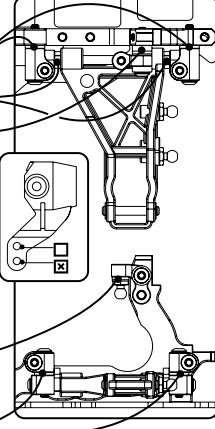

### Front Shocks

Oil  30 WT

Springs  Schu. Blau

Piston Holes  2  3

length  61,6

Rebound  30 %

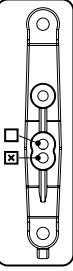
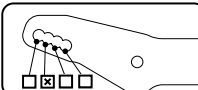
### Centre Track Rod

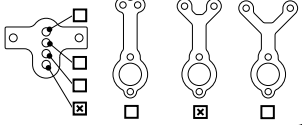

### REAR SETTINGS

Drive Height  High  Low

Toe In  In-board  Out-board  ° 3,20 °

Screw Block Spacers  Front 1,50 mm  Rear 1,0 mm

Wishbone Quik-Klips  Front 2,0 mm  Rear 2,0 mm

Link Washers (Horizontal)  2,5 mm

Ride Height (Chassis to Floor)  5,0 mm

Droop (Chassis to Floor)  3,0 mm

Anti-roll Bar  Yes  No  1,20  1,40  1,60

Camber  Positive  Negative  1,50 Deg

Link Washers (Vertical)  2,0 mm

Inboard Pin  Pro-Squat  Anti-Squat  Horizontal

Pivot Block Spacers  Front 1,0 mm  Rear 1,0 mm

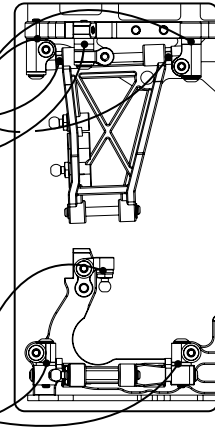

### Rear Shocks

Oil  30 WT

Springs  62,7

Piston Holes  2  3

length  Schu. Weiß

Rebound  30 %

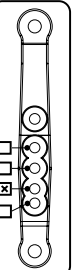
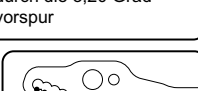
### Driver Notes

sehr Stabiles Heck durch die 3,20 Grad vorspur