

### DRIVER AND EVENT DETAILS

Name

Date

Event

Weather

Result

### CHASSIS AND ELECTRICS

Chassis

Top Deck Flex  Standard  Stiff

Bodyshell

Wing

E.S.C.

Servo

Receiver

Number of Cells 4  5  6

Type of Cells

### TRACK CONDITIONS

Grip Level High  Medium  Low

Track Type Tight  Open  Both

Surface Carpet  Tarmac  Wood

Venue Indoor  Outdoor

Track Condition Smooth  Bumpy

Track Temperature  °C  °F



### DRIVER NOTES

### MOTOR AND GEARING

Type Brushed  Brushless

Motor

Brush

Spring

Timing

Gear Pitch 48Dp  64Dp

Spur Size

Pinion Size

### WHEELS, TYRES AND INSERTS

Wheels

Tyres

Inserts

Tyre Additive

Additive Time MIN (R)  MIN (F)

Tyre Warmers Yes  No

### FRONT SETTINGS

Drive Diff  Spool  One-Way  Height High  Low

Servo Saver Yes  No

Toe In-Out In-board  Out-board  ° Toe-out

Screw Block Spacers Front  mm Rear  mm

Wishbone Quik-Klips Front  mm Rear  mm

Link Washers (Horizontal)  mm

Ride Height (Chassis to Floor)  mm

Droop (Chassis to Floor)  mm

Anti-roll Bar Yes  No  1.20  1.40  1.60

Castor 0°  2°  4°  6°

Camber Positive  Negative  Deg

Link Washers (Vertical)  mm

Inboard Pin Kick-up  Anti-dive  Horizontal

Pivot Block Spacers Front  mm Rear  mm

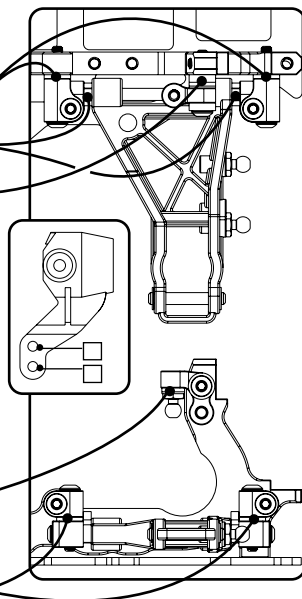

### Front Shocks

Oil  WT

Springs

Piston Holes 2  3

length

Rebound  %

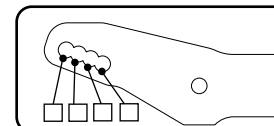
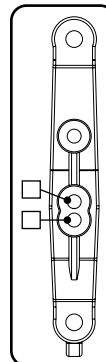

### Centre Track Rod

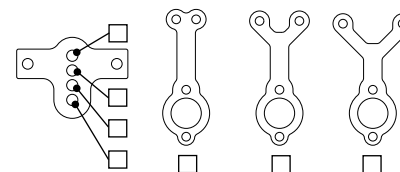

### REAR SETTINGS

Drive Height High  Low

Toe In In-board  Out-board  °

Screw Block Spacers Front  mm Rear  mm

Wishbone Quik-Klips Front  mm Rear  mm

Link Washers (Horizontal)  mm

Ride Height (Chassis to Floor)  mm

Droop (Chassis to Floor)  mm

Anti-roll Bar Yes  No  1.20  1.40  1.60

Camber Positive  Negative  Deg

Link Washers (Vertical)  mm

Inboard Pin Pro-Squat  Anti-Squat  Horizontal

Pivot Block Spacers Front  mm Rear  mm

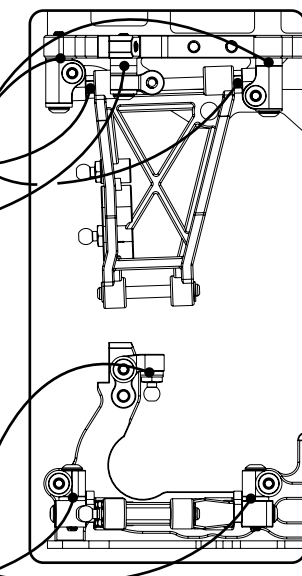

### Rear Shocks

Oil  WT

Springs

Piston Holes 2  3

length

Rebound  %

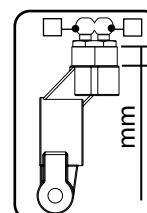
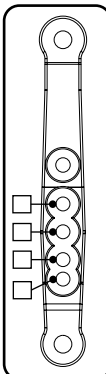

### Driver Notes

