

DRIVER AND EVENT DETAILS

Name

Date

Event

Weather

Result

CHASSIS AND ELECTRICS

Chassis

Top Deck

Bodyshell

Wing

E.S.C

Servo

Receiver

Number of Cells 4 5 6

Type of Cells

TRACK CONDITIONS

Grip Level High Medium Low

Track Type Tight Open Both

Surface Carpet Tarmac Wood

Venue Indoor Outdoor

Track Condition Smooth Bumpy

Track Temperature °C °F

MOTOR AND GEARING

Type Brushed Brushless

Motor

Brush

Spring

Timing

Gear Pitch 48Dp 64Dp

Spur Size

Pinion Size

Amo@pettrc.com



DRIVER NOTES

WHEELS, TYRES AND INSERTS

Wheels

Tyres

Inserts

Tyre Additive

Additive Time MIN (R) MIN (F)

Tyre Warmers Yes No

FRONT SETTINGS

Drive Diff Spool One-Way Height High Low

Servo Saver Yes No

Toe In-Out In-board Out-board ° Toe-out

Screw Block Spacers Front mm Rear mm

Wishbone Quik-Klips Front mm Rear mm

Link Washers (Horizontal) mm

Ride Height (Chassis to Floor) mm

Droop (Chassis to Floor) mm

Anti-roll Bar Yes No 1.20 1.40 1.60

Castor 0° 2° 4° 6°

Camber Positive Negative Deg

Link Washers (Vertical) mm

Inboard Pin Kick-up Anti-dive Horizontal

Pivot Block Spacers Front mm Rear mm

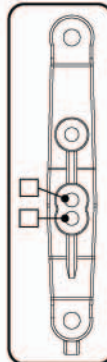
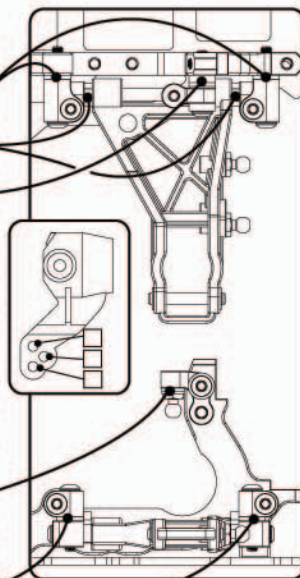

Front Shocks

Oil WT

Springs

Piston Holes 2 3

length

Rebound %

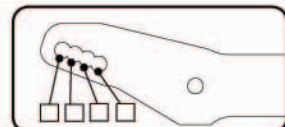

Centre Track Rod

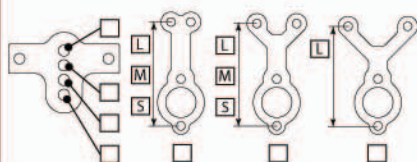

REAR SETTINGS

Drive Height High Low

Toe In In-board Out-board °

Screw Block Spacers Front mm Rear mm

Wishbone Quik-Klips Front mm Rear mm

Link Washers (Horizontal) mm

Ride Height (Chassis to Floor) mm

Droop (Chassis to Floor) mm

Anti-roll Bar Yes No 1.20 1.40 1.60

Camber Positive Negative Deg

Link Washers (Vertical) mm

Inboard Pin Pro-Squat Anti-Squat Horizontal

Pivot Block Spacers Front mm Rear mm

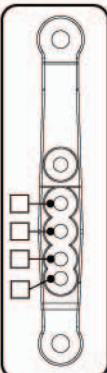
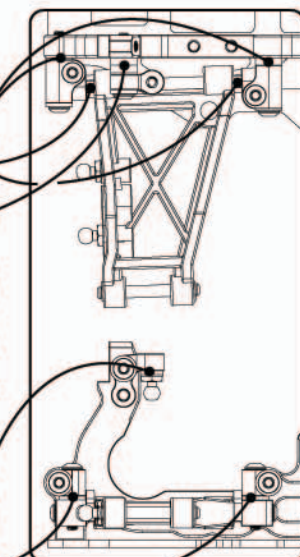

Rear Shocks

Oil WT

Springs

Piston Holes 2 3

length

Rebound %

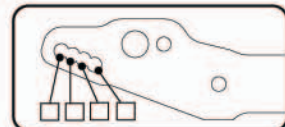

Driver Notes