

DRIVER AND EVENT DETAILS

Name Adam Mackman
 Date 21/22 feb 09
 Event carpet wars world cup 2 day
 Weather
 Result qual 6 fin 6

CHASSIS AND ELECTRICS

Chassis 2mm
 Top Deck 2.5mm stiff
 Bodyshell hb mps
 Wing
 E.S.C lrp tc punch 6 drag 0
 Servo ko lp 30% curve 80% lock
 Receiver spectrum micro
 Number of Cells 4 5 6
 Type of Cells core rc 5000 lipo

TRACK CONDITIONS

Grip Level High Medium Low
 Track Type Tight Open Both
 Surface Carpet Tarmac Wood
 Venue Indoor Outdoor
 Track Condition Smooth Bumpy
 Track Temperature °C °F

MOTOR AND GEARING

Type Brushed Brushless
 Motor novak 10.5
 Brush
 Spring
 Timing max
 Gear Pitch 48Dp 64Dp
 Spur Size 116
 Pinion Size 36



DRIVER NOTES

lightweight spool. tir shafts. wide rear shock tower. hpi pink blue better when grip was higher. 20g front corners 15g near servo horn

WHEELS, TYRES AND INSERTS

Wheels sorex 28
 Tyres glue front side walls
 Inserts
 Tyre Additive lrp full
 Additive Time 20 MIN (R) MIN (F)
 Tyre Warmers Yes No

FRONT SETTINGS

Drive Diff Spool One-Way Height High Low

Servo Saver Yes No
 Toe In-Out In-board Out-board 0 ° Toe-out
 Screw Block Spacers Front 1.5 mm Rear 1.5 mm
 Wishbone Quik-Klips Front 2 mm Rear 2 mm
 Link Washers (Horizontal) 2.5 mm
 Ride Height (Chassis to Floor) 5.5 mm
 Droop (Chassis to Floor) 4.5 mm
 Anti-roll Bar Yes No 1.20 1.40 1.60
 Castor 0° 2° 4° 6°
 Camber Positive Negative 1.5 Deg
 Link Washers (Vertical) 0.5 mm
 Inboard Pin Kick-up Anti-dive Horizontal
 Pivot Block Spacers Front 1 mm Rear 1 mm

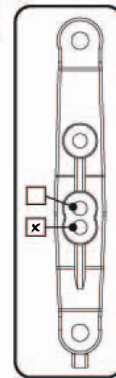
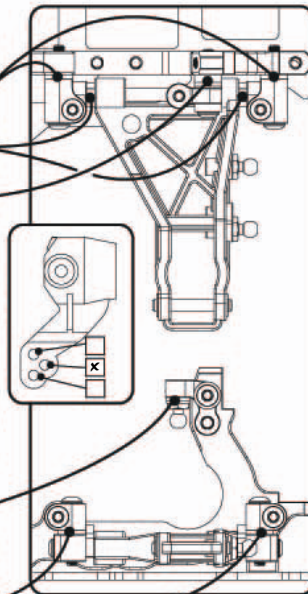

Front Shocks

Oil 50 WT
 Springs xray 2.8
 Piston Holes 2 3
 length 62.5
 Rebound 75 %

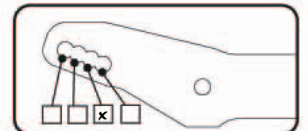

Centre Track Rod

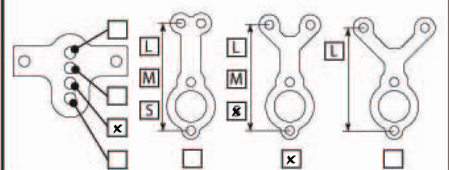

REAR SETTINGS

Drive Height High Low

Toe In In-board Out-board °
 Screw Block Spacers Front 2.5 mm Rear 1.5 mm
 Wishbone Quik-Klips Front 3 mm Rear 1 mm
 Link Washers (Horizontal) 2.5 mm
 Ride Height (Chassis to Floor) 5.5 mm
 Droop (Chassis to Floor) 4 mm
 Anti-roll Bar Yes No 1.20 1.40 1.60
 Camber Positive Negative 2 Deg
 Link Washers (Vertical) 2.5 mm
 Inboard Pin Pro-Squat Anti-Squat Horizontal
 Pivot Block Spacers Front 2 mm Rear 2 mm

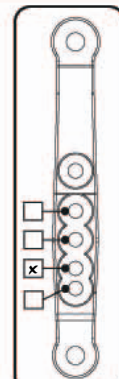
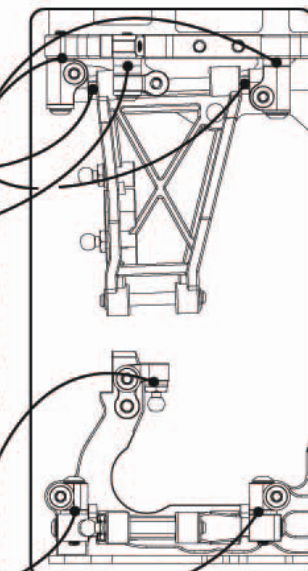

Rear Shocks

Oil 40 WT
 Springs 2.6
 Piston Holes 2 3
 length 63.5
 Rebound 75 %

Driver Notes

lightweight spool. tir shafts. wide rear shock tower. hpi pink blue better when grip was

