

Driver:
Date:
Meeting:
Best Time:

E Schumacher



FRONT SETTINGS

Ride Height *mm*
 Anti-Roll Bar.....
 Castor..... 2° 4° 6°
 Kick Up..... *mm* Anti-Dive..... *mm*
 Toe-In/Out..... *degrees*
 Roll Centre *mm*
 Camber..... *degrees*
 Wishbone..... Short Mid/Short Mid/Long Long

Notes:

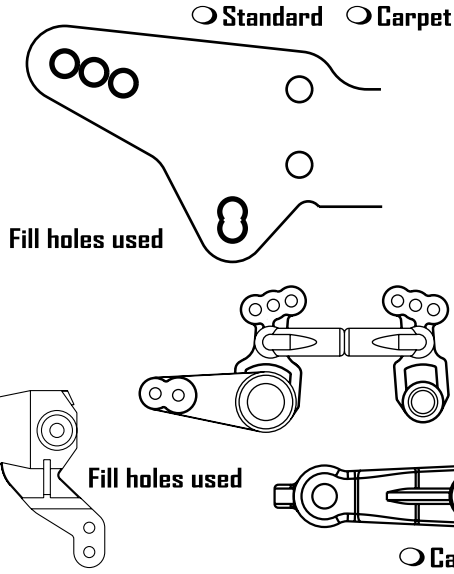

FRONT SHOCKS

Oil.....
 Spring.....
 Piston.....2...3...
 Length.....*mm*..
 Droop.....*mm*..

REAR SETTINGS

Ride Height *mm*
 Anti-Roll Bar.....
 Anti/Pro Squat.....
 Toe-In (In)..... *degrees*
 Roll Centre *mm*
 Camber..... *degrees*
 Wishbone..... Short Mid/Short Mid/Long Long

Notes:

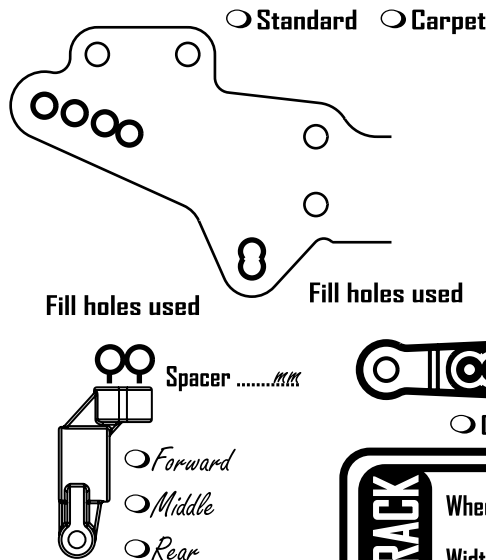

REAR SHOCKS

Oil.....
 Spring.....
 Piston.....2...3...
 Length.....*mm*..
 Droop.....*mm*..

OTHER SETTINGS

Bodyshell.....
 Differential..... Standard Locked One-Way
 Chassis
 Top Deck
 E.S.C.
 Cells
 Servo.....
 Receiver

MOTOR & GEARING

Motor.....
 Brush.....
 Spring.....
 Timing..... *degrees*
 Pinion Size..... *tooth*
 Spur Size..... *tooth*

TYRES & WHEELS

Front Tyres.....
 Rear Tyres.....
 Front Inserts.....
 Rear Inserts.....
 Wheel.....
 Tyre Additive..... Yes No *Type*

DRIVERS NOTES

TRACK CONDITIONS

VENUE Indoor
 Outdoor

SURFACE Carpet
 Concrete
 Tarmac

TYPE Tight
 Open

GRIP High
 Medium
 Low

CONDITION Smooth
 Bumpy

TRACK

WheelBase *mm*
 Width Front..... *mm*..Rear..... *mm*..