

Driver:  
Date:  
Meeting:  
Best Time:

Schumacher



**FRONT SETTINGS**

Ride Height ..... *mm*  
 Anti-Roll Bar.....  
 Castor.....  2°     4°     6°  
 Kick Up..... *mm*    Anti-Dive..... *mm*  
 Toe-In/Out..... *degrees*  
 Roll Centre ..... *mm*  
 Camber..... *degrees*  
 Wishbone.....  Short    Mid/Short    Mid/Long    Long

Notes:

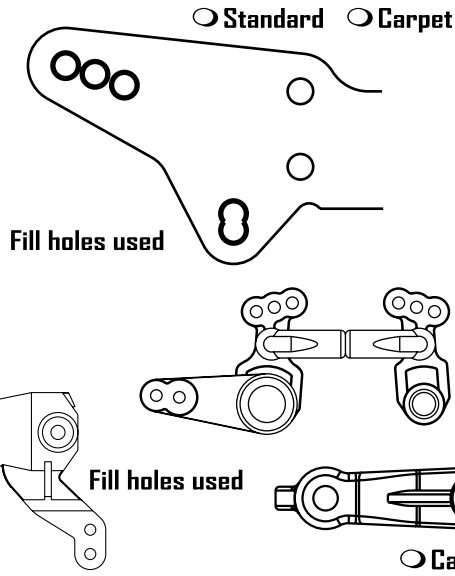

**FRONT SHOCKS**

Oil.....  
 Spring.....  
 Piston.....2...3...  
 Length.....*mm*..  
 Droop.....*mm*..

**REAR SETTINGS**

Ride Height ..... *mm*  
 Anti-Roll Bar.....  
 Anti/Pro Squat.....  
 Toe-In (In)..... *degrees*  
 Roll Centre ..... *mm*  
 Camber..... *degrees*  
 Wishbone.....  Short    Mid/Short    Mid/Long    Long

Notes:

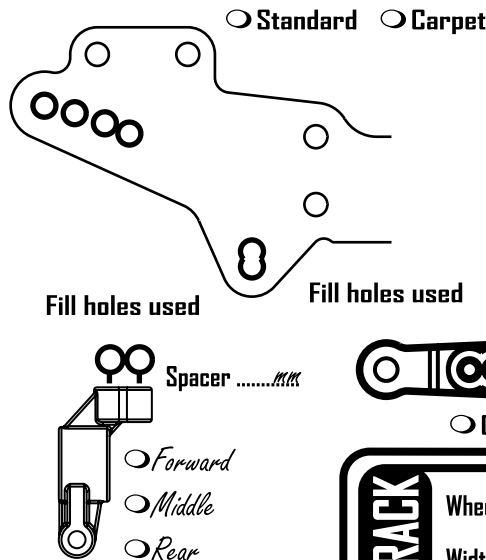

**REAR SHOCKS**

Oil.....  
 Spring.....  
 Piston.....2...3...  
 Length.....*mm*..  
 Droop.....*mm*..

**OTHER SETTINGS**

Bodyshell.....  
 Differential.....  Standard    Locked    One-Way  
 Chassis .....  
 Top Deck .....  
 E.S.C. ....  
 Cells .....  
 Servo.....  
 Receiver .....

**MOTOR & GEARING**

Motor.....  
 Brush.....  
 Spring.....  
 Timing..... *degrees*  
 Pinion Size..... *tooth*  
 Spur Size..... *tooth*

**TYRES & WHEELS**

Front Tyres.....  
 Rear Tyres.....  
 Front Inserts.....  
 Rear Inserts.....  
 Wheel.....  
 Tyre Additive.....  Yes    No   *Type*

**DRIVERS NOTES**

**TRACK CONDITIONS**

**VENUE**    Indoor  
                    Outdoor

**SURFACE**    Carpet  
                    Concrete  
                    Tarmac  
                    .....

**TYPE**    Tight  
               Open

**GRIP**    High  
               Medium  
               Low

**CONDITION**    Smooth  
                       Bumpy

**TRACK**

WheelBase ..... *mm*  
 Width Front..... *mm* ..Rear..... *mm*