

DRIVER DETAILS

NAME *Robert Krens*
 DATE *01-06-2015*
 EVENT *Dutch Nationals round 2 - HFCC Racing*
 WEATHER *Dry, Sunny, 24degC*
 RESULT *Q: TQ, F: P3 25R in 5:14 FL17,57*

CHASSIS AND ELECTRICS

CHASSIS Rear Motor Mid Motor
 TOP DECK *STD + extra bar*
 BODYSHELL *Protoform Mazda Speed 6 GX*
 WING *JG Racing Wing 10mm over*
 E.S.C *Much More Fleta Euro's*
 SERVO *Futaba 9551*
 RECIEVER *Sanwa 451R*
 CELLS *Dualsky 6250Mah 90C*
 CELL POSITION Forward Middle Rearward

TRACK CONDITIONS

GRIP LEVEL High Medium Low
 TYPE Tight Open Mixed
 SURFACE Carpet Tarmac
 CONDITION Smooth Bumpy
 TEMPERATURE °C °F *35degC tarmac*
 VENUE Indoor Outdoor

NOTES

Car is awesome fast. Tires are shit!
MR33 + Lamp also works.

Mi5

Schumacher
 racing-cars.com

MOTOR AND GEARING

MOTOR *Much More Fleta ZX 13,5T 'Zero Degree'*
 ROTOR DIAMETER *12,3mm*
 TIMING *~ 12 degree*
 GEAR PITCH 48DP 64DP
 SPUR SIZE *96*
 PINION SIZE *38*

WHEELS, TYRES AND INSERTS

WHEELS *Ride Rex 27027*
 TYRES *Ride Rex 34R*
 INSERTS *Yellow*
 TYRE ADDITIVE *Mighty Gripper V3*
 ADDITIVE TIME Front *20* Minutes Rear *20* Minutes
 TYRE WARMERS Yes No Temp *70 °C* Time *10* Minutes

REAR

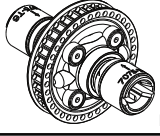

Ball Diff
 Gear Diff
 Diff Oil *900* cTs



1.1mm - Yellow
 1.2mm - Red
 1.3mm - Green
 1.4mm - Blue
 1.5mm - Grey
 1.6mm - Orange

Droop.....*2.5*...mm
 On 10mm Block
 Ride Height*5.8*...mm
 Camber.....*3*...Degree's

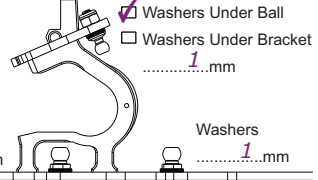

Washers Under Ball
 Washers Under Bracket
*1*...mm

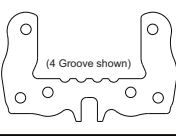

3 Groove 39mm
 4 Groove 37mm
 (4 Groove shown)

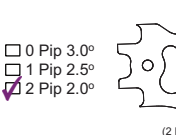

0 Pip 3.0°
 1 Pip 2.5°
 2 Pip 2.0°
 (2 Pip shown)

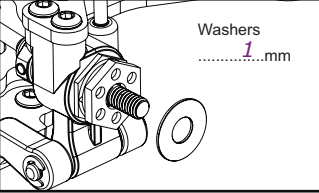

Washers
*1*...mm

0 Groove
 1 Groove
 2 Groove



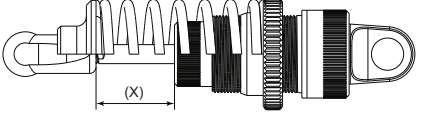

CAP TYPE Vented Sealed Emulsion
 OIL.....*350*...cTs
 SPRING...*Schumi Green*.....
 PISTON...*#3*.....
 DRILLED Yes No
 DRILLED PISTON HOLE SIZE.....*1.1*...mm
 SHOCK LENGTH (X).....*11.54*...mm
 REBOUND *0%*.....

Alloy Steel

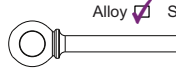

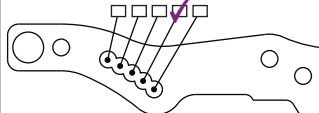

FRONT

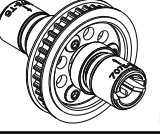

Spool
 Gear Diff
 Diff Oil *1Mil* cTs



1.1mm - Yellow
 1.2mm - Red
 1.3mm - Green
 1.4mm - Blue
 1.5mm - Grey
 1.6mm - Orange

Washers Under Ball
 Washers Under Bracket
*1*...mm

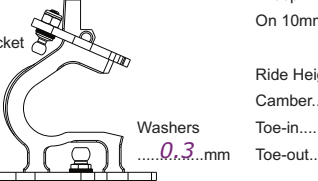

Washers
*0.7*...mm

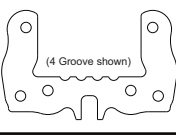

3 Groove 39mm
 4 Groove 37mm
 (4 Groove shown)

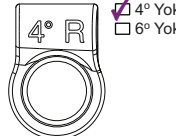

4° Yoke
 6° Yoke
 Yes No
 SERVO SAVER

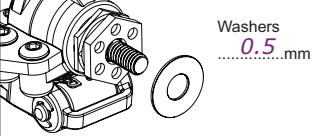

Washers
*0.5*...mm

Washers
*0.5*...mm

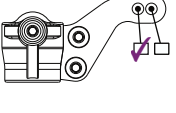

Washers
*1*...mm

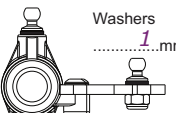

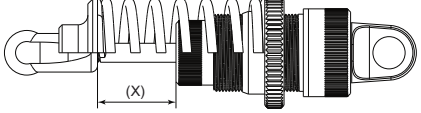

CAP TYPE Vented Sealed Emulsion
 OIL.....*300*...cTs
 SPRING...*Schumi Green*.....
 PISTON...*#3*.....
 DRILLED Yes No
 DRILLED PISTON HOLE SIZE.....*1.1*...mm
 SHOCK LENGTH (X).....*11.54*...mm
 REBOUND *0%*.....

Alloy Steel Double Joint

