



**A**  
BAG



①~②  
Kit Bag A

① Lower deck

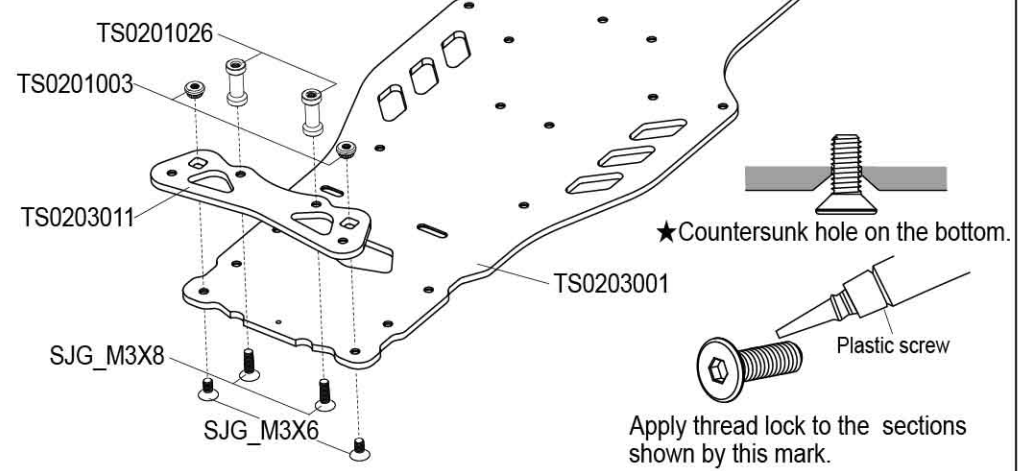
-  (h=15mm)  
TS0201026 .....2
-  .....2
-  .....2
-  .....2



②



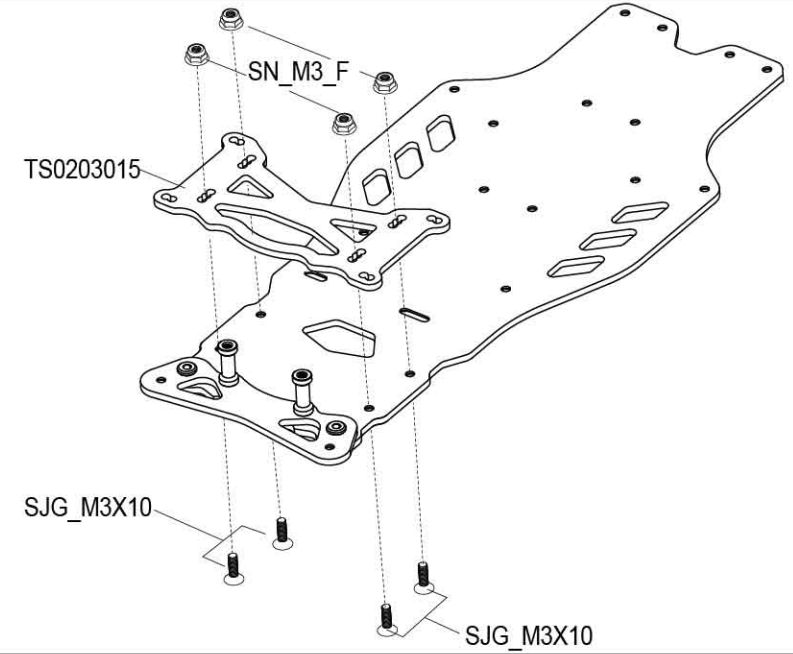



-  .....4
-  .....4



③

**B**  
BAG

③~④  
Kit Bag B

-  .....2
-  (h=23mm) .....2
-  (h=2.5mm) .....6
-  .....4
-  .....2
-  .....2

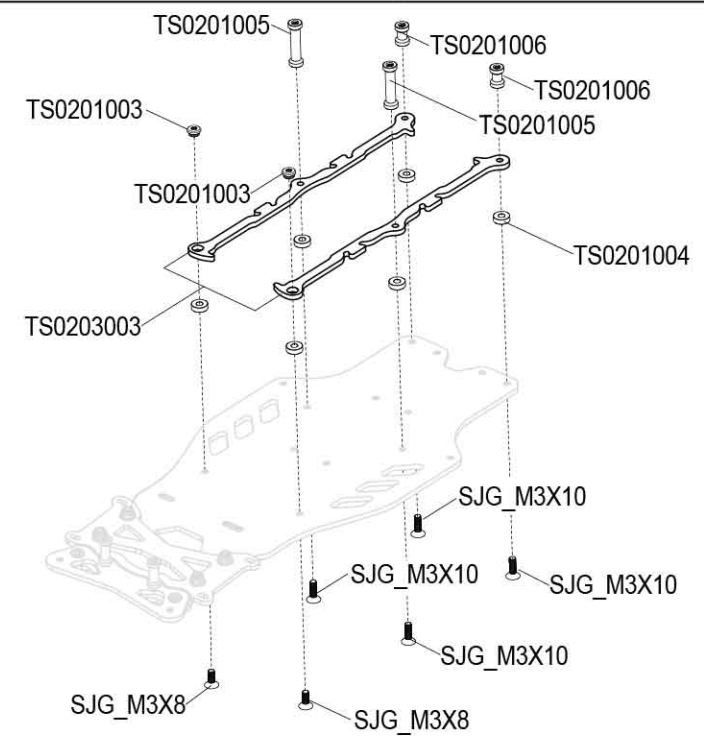

Ver 1.01

**C**  
BAG

⑤~⑦  
Kit Bag C

-  .....1
-  .....2
-  .....3
-  .....2

⑤ Lower brace

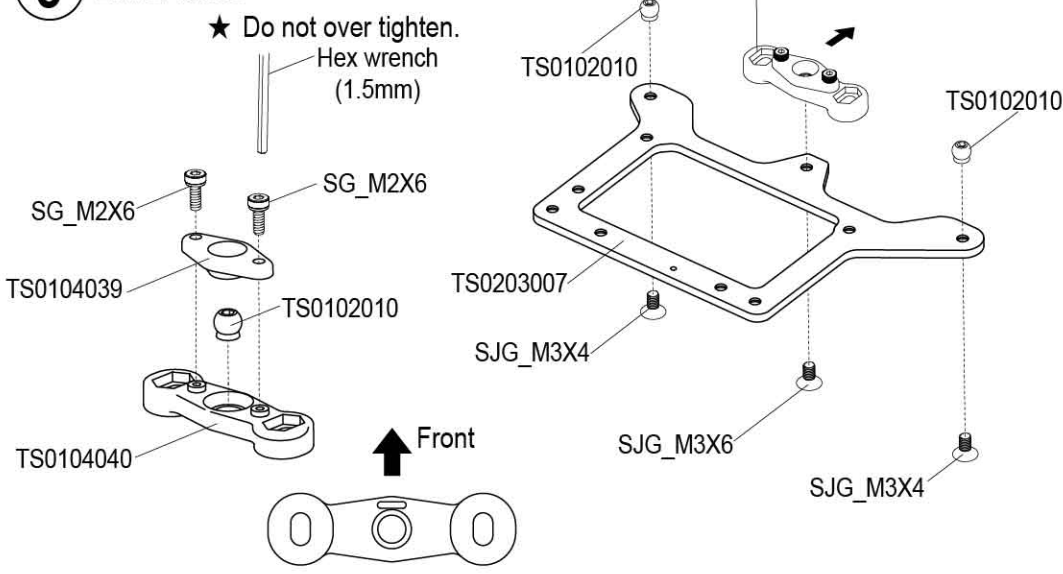

⑥ Attaching lower brace

-  .....2
-  .....2

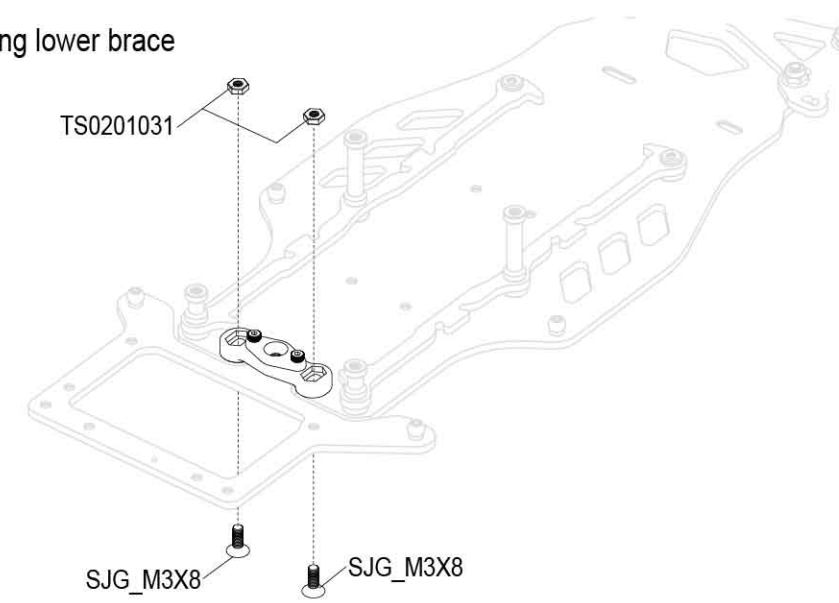

- SG\_M2X6 .....4
- TS0104038 .....2

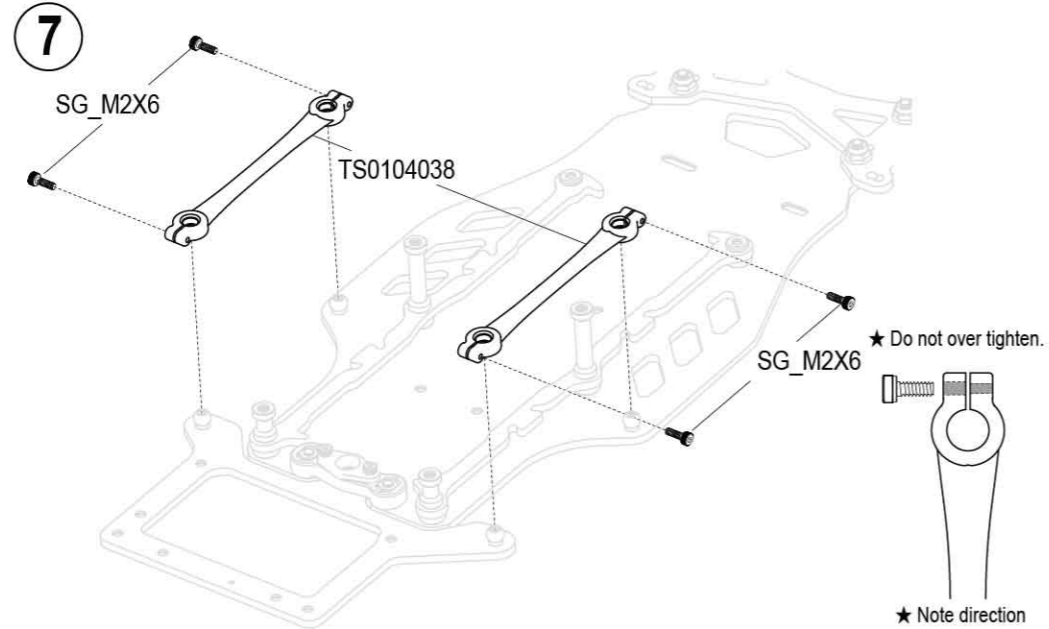

**D**  
BAG

**8**  
Kit Bag D

- SJG\_M3X8 .....5
- SIG\_M3X6 .....4
- TS0101021 .....1
- TS0101020 .....1

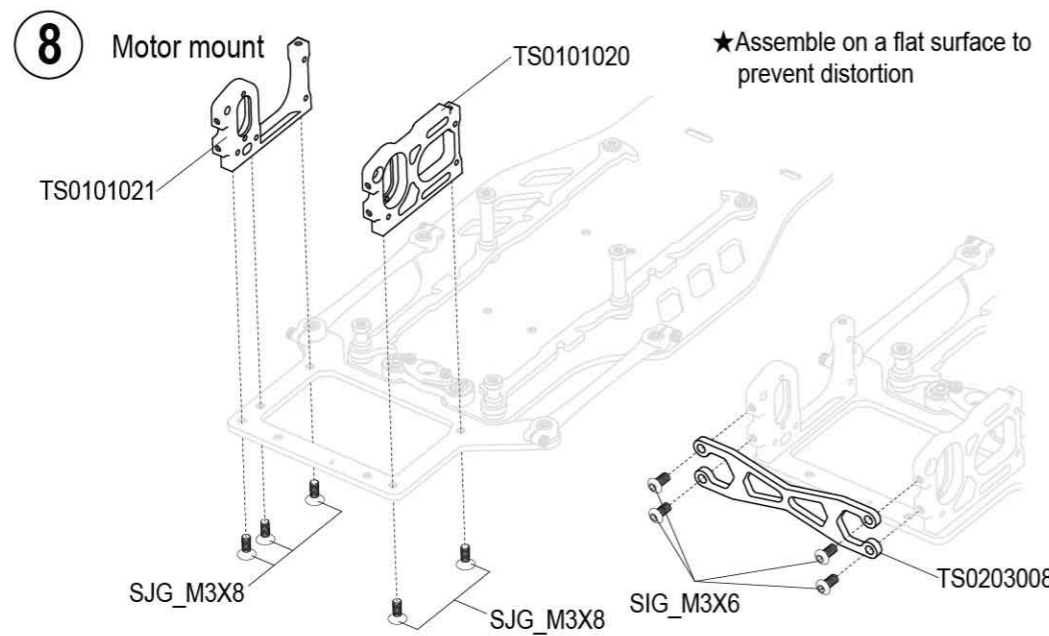

**E**  
BAG

**9~10**  
Kit Bag E

- TS0201019 .....1
- TS0201018 .....1
- MR\_106-OR .....2
- TS0201022 .....1
- SK\_3X3 .....2

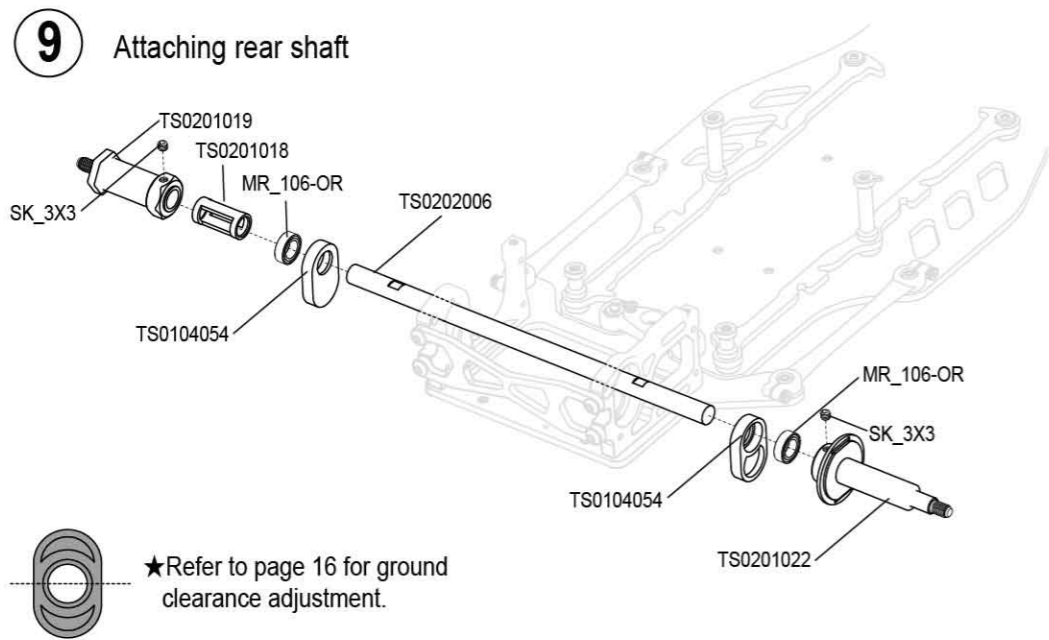

- 5x11x4
- MR115-OR .....1
- 8x12x3.5
- MR128-OR .....1
- TS0102011 .....2
- TS0102006 .....12
- TS0101006 .....1
- TS0204012 .....1
- SIG\_M3X4 .....3

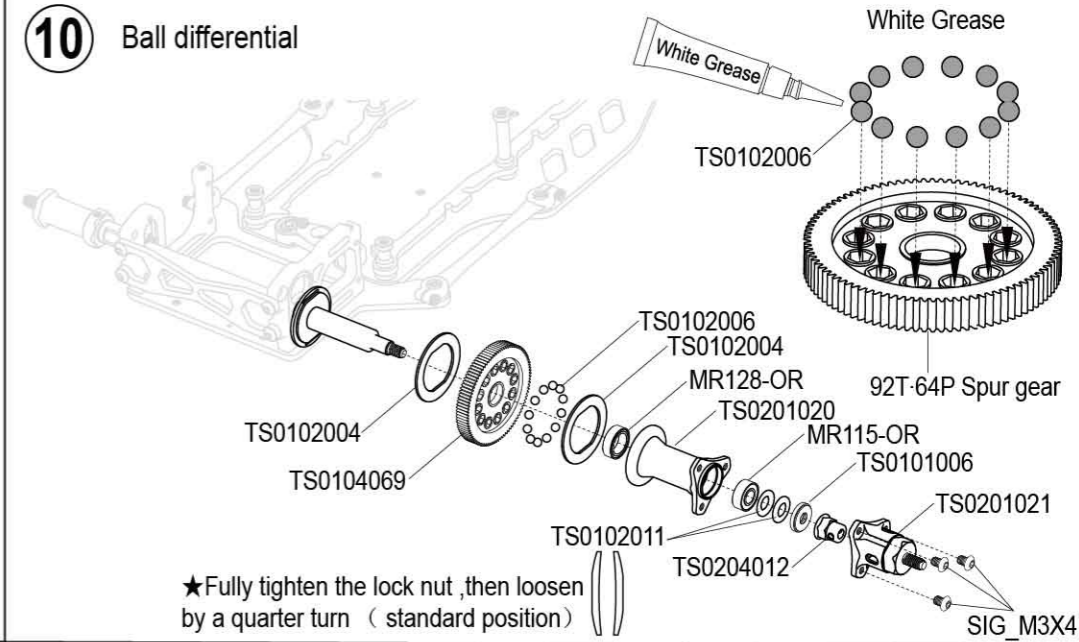

**F**  
BAG



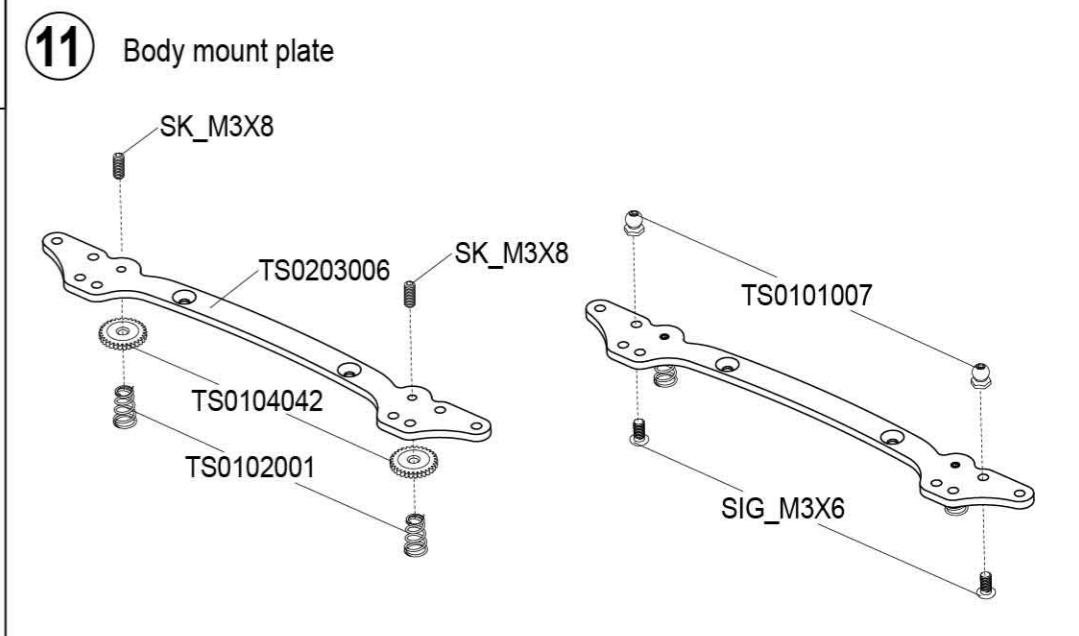

**11~16**  
Kit Bag F

- TS0104042 .....2
- TS0102001 .....2
- SK\_M3X8 .....2
- TS0101007 .....2
- SIG\_M3X6 .....2

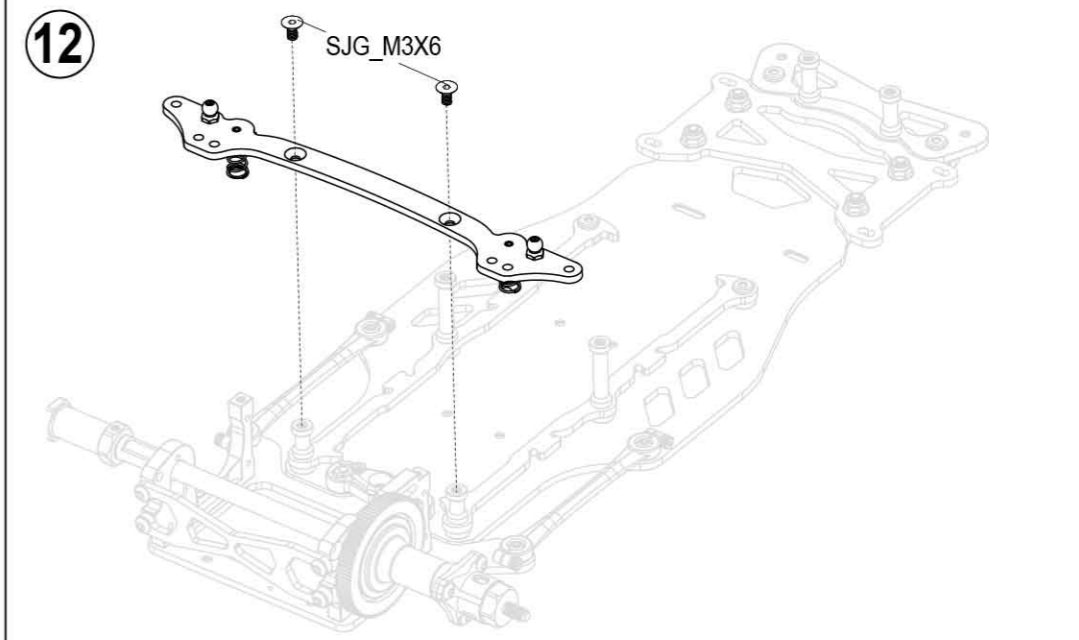





- SJG\_M3X6 .....2

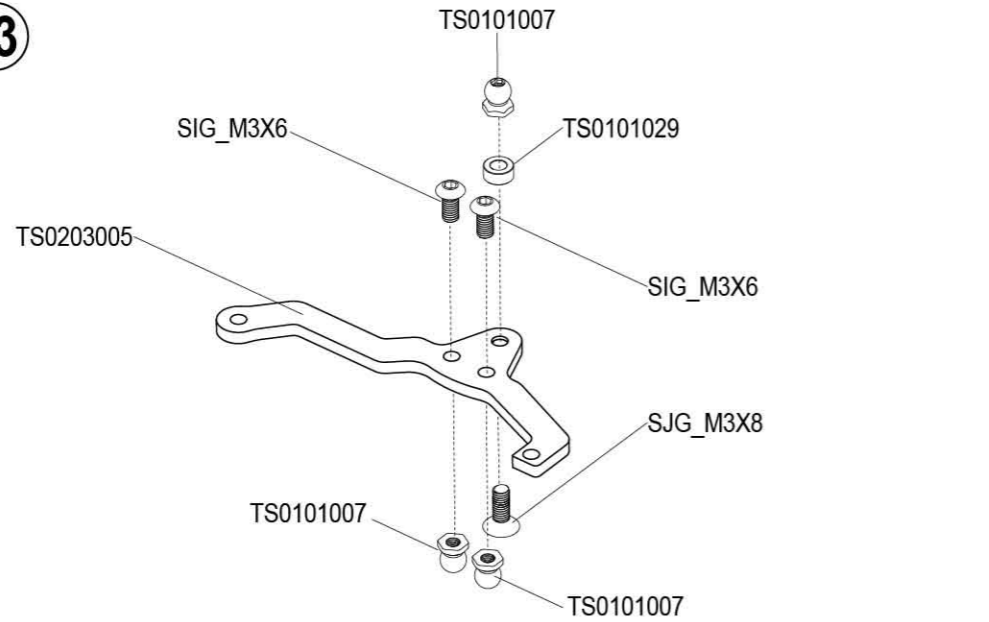

-  TS0101007 .....3
-  TS0101029 .....1
-  SIG\_M3X6 .....2
-  SJG\_M3X8 .....1

**13**



-  (L=13.5mm) TS0104026 .....4
-  TS0101018 .....2
-  TS0104080 .....2
-  SK\_M3X10 .....2



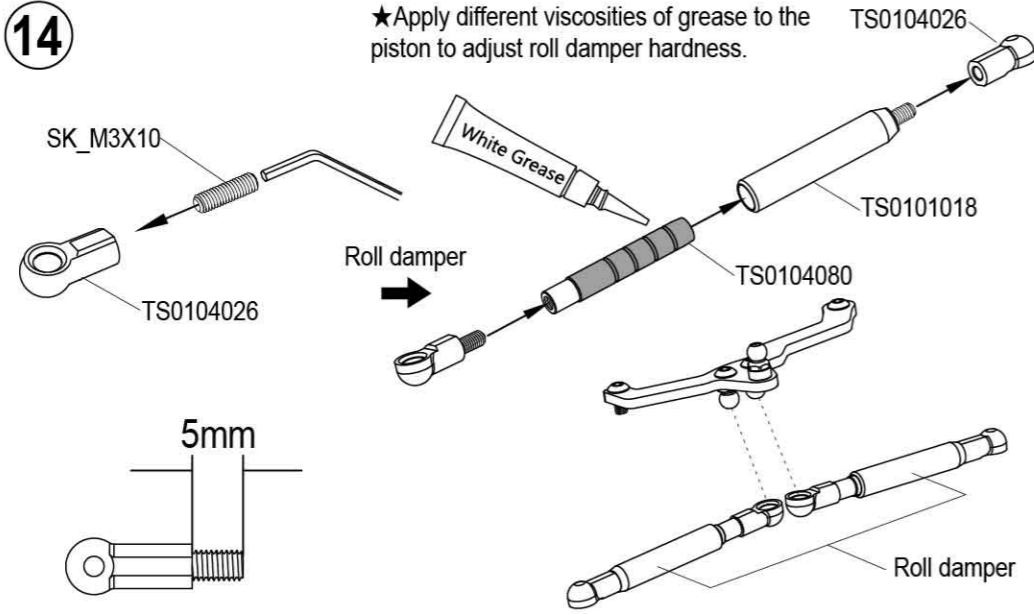

**14**

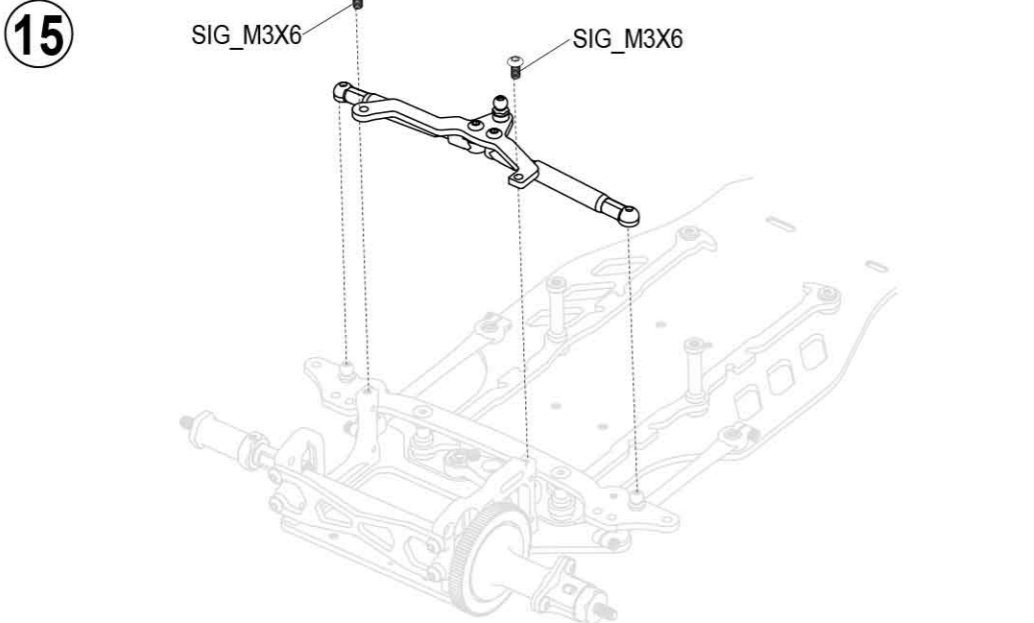

-  SIG\_M3X6 .....2

**15**





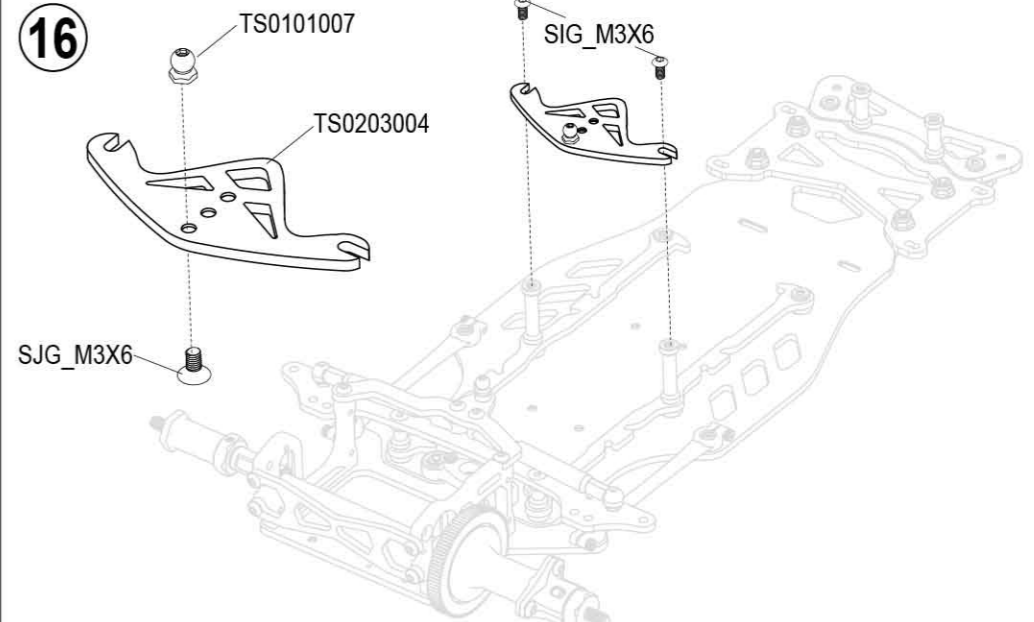

-  TS0101007 .....1
-  TS0203004 .....1
-  SJG\_M3X6 .....1
-  SIG\_M3X6 .....2

**16**







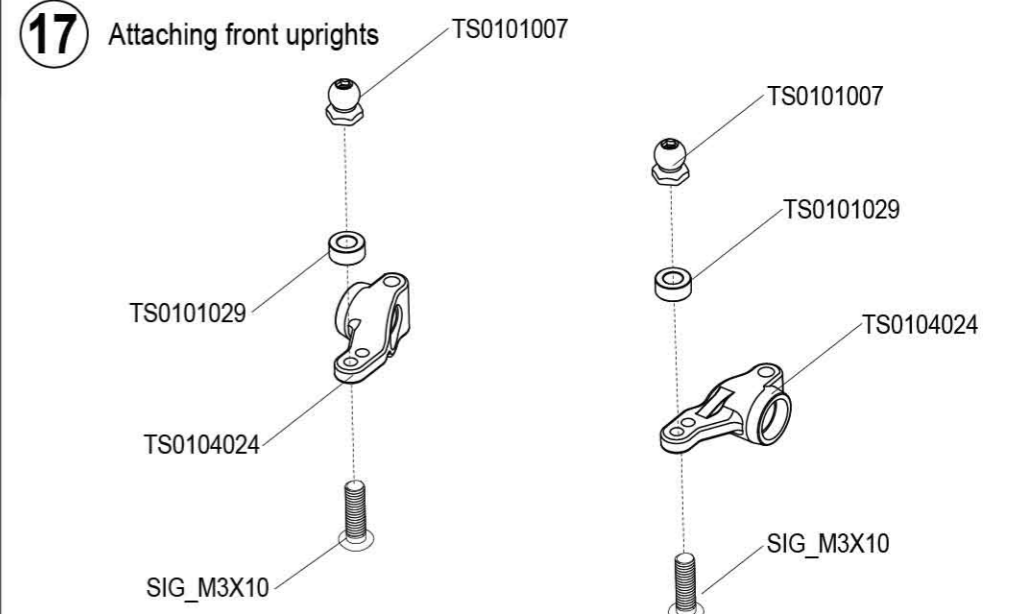

**G**  
BAG Kit Bag G

-  TS0104024 .....2
-  TS0101007 .....2
-  TS0101029 .....2
-  SIG\_M3X10 .....2

**17**



-  TS0201804 .....2
-  TS0202010 .....2
-  TS0202007 .....2
-  5X8X2.5 MR085-OR .....4
-  5X7X0.5 TS0102018 .....2
-  SG-M1.6X5 .....2

**18**

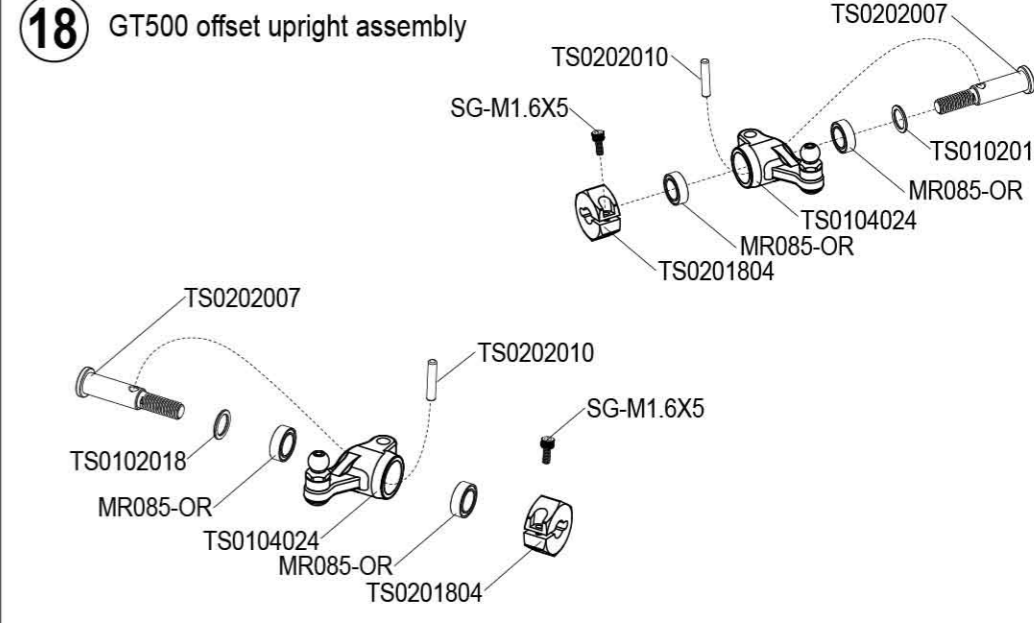

- TS0204004 .....2
- TS0204002 .....2
- TS0202003 .....2
- TS0204005 .....2

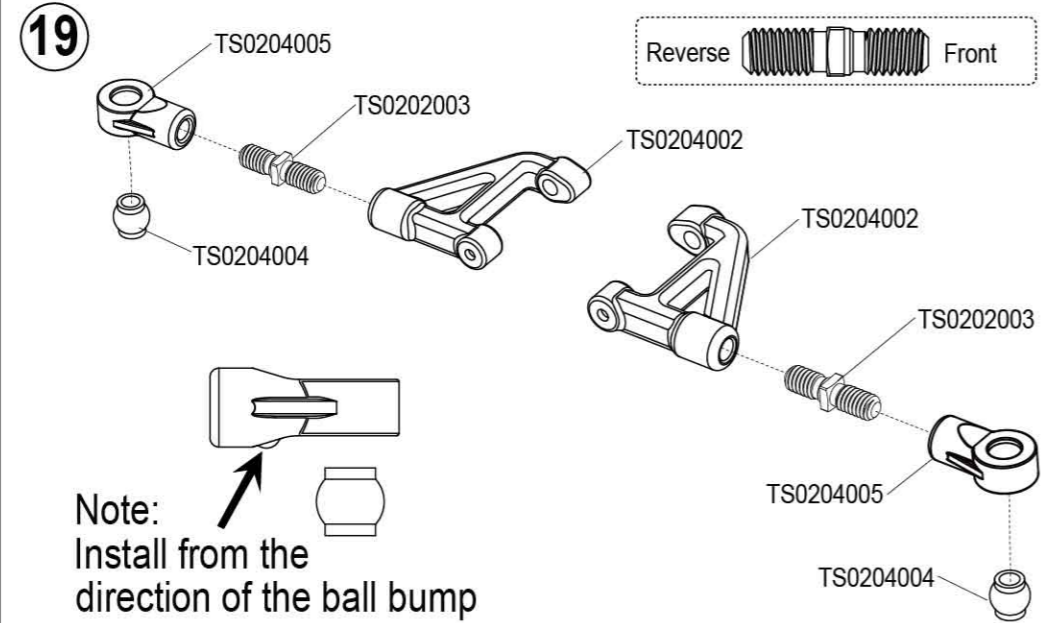

- TS0203019 .....1
- SIG\_M2X4 .....2
- TS0202002 .....2

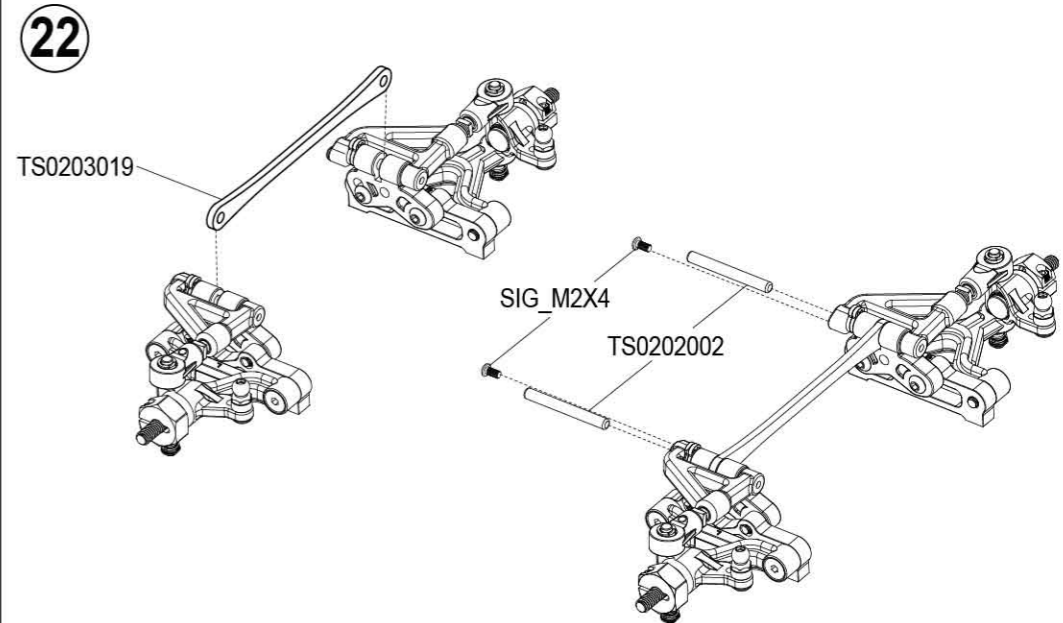

- TS0204004 .....2
- TS0201001 .....2
- TS0204001 .....2
- SJG\_M3X12 .....4
- SIG\_M3X10 .....4

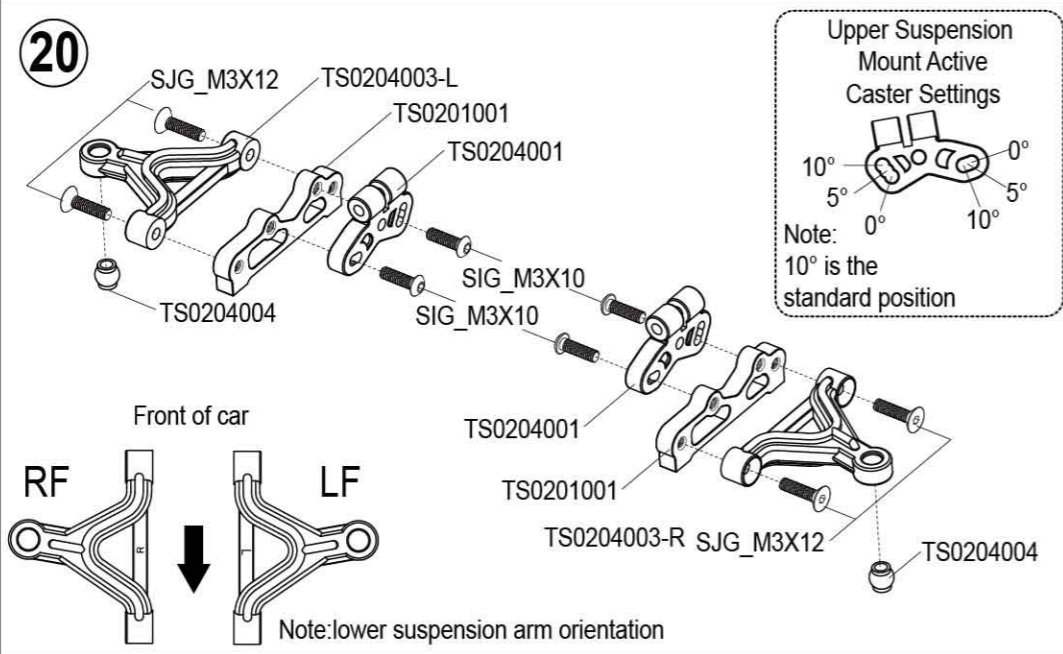

- TS0201025 .....4
- TS0201015 .....4
- TS0201002 .....4
- TS0201014 .....4
- SIG\_M3X12 .....4

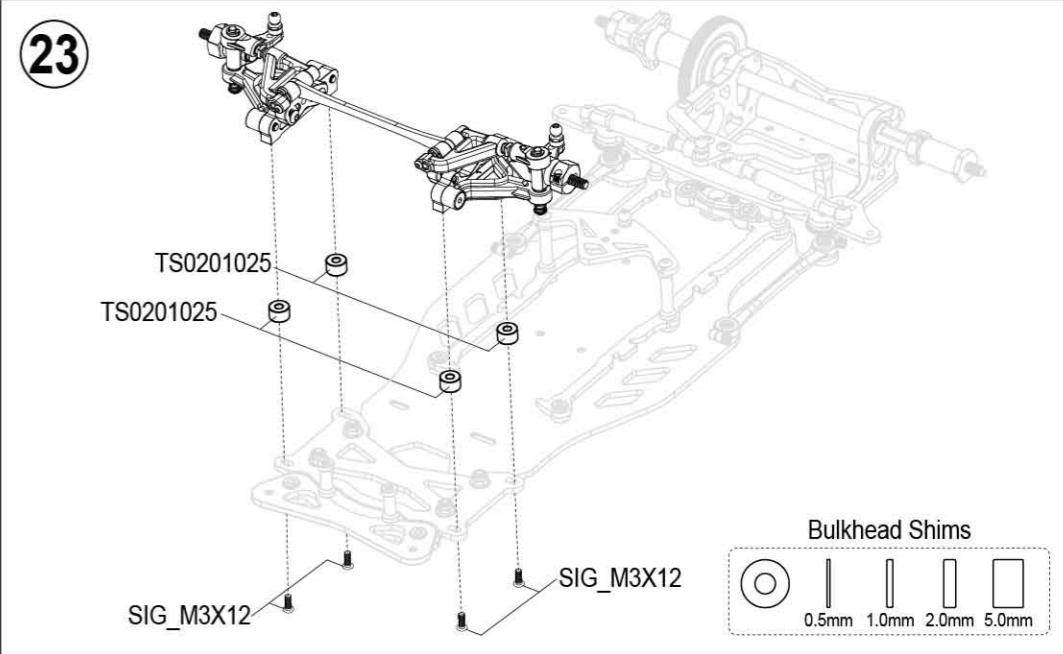



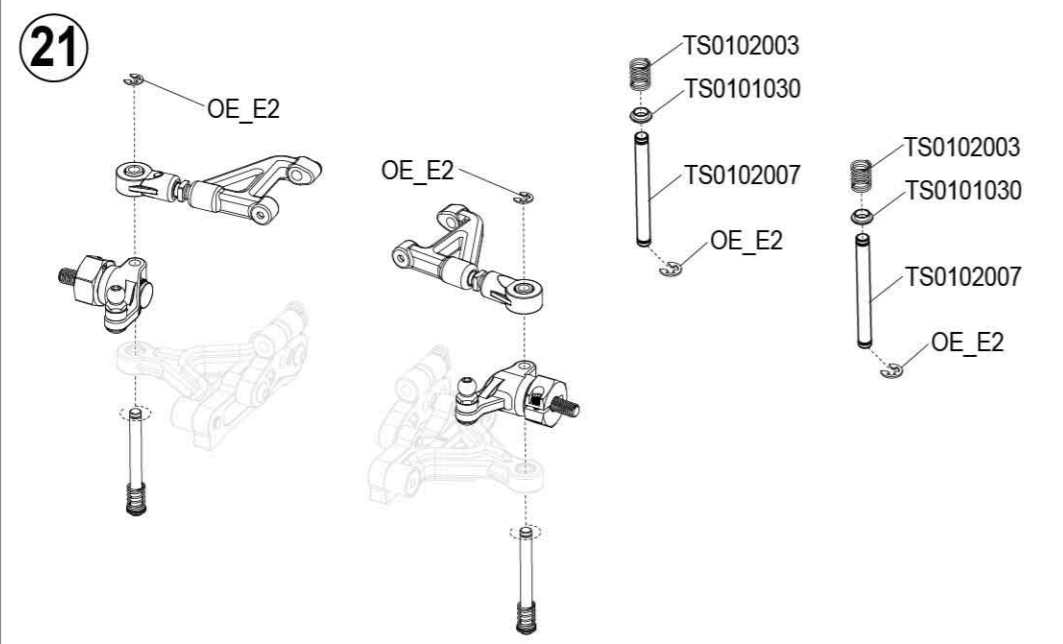

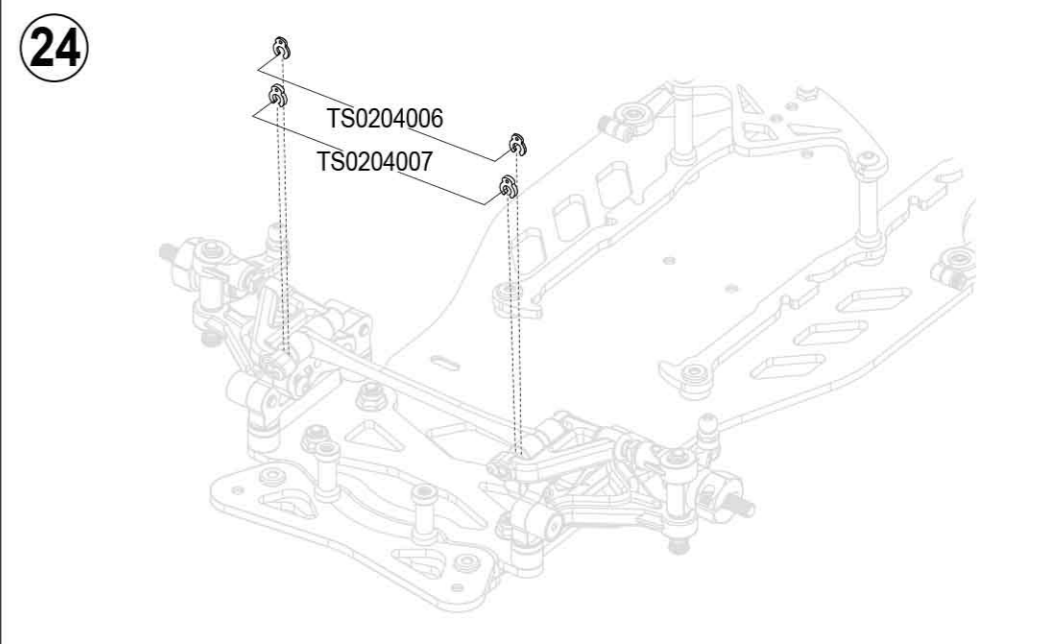

- OE\_E2 .....2
- TS0101030 .....2
- TS0102003 .....2
- TS0102007 .....2



- TS0204006 .....2
- TS0204007 .....2



**25** Damper assembly

-  TS0105004 .....1
-  TS0104034 .....1
-  TS0104037 .....1
-  TS0102009 .....1
-  OE\_E2 .....2
-  TS0105002 .....1

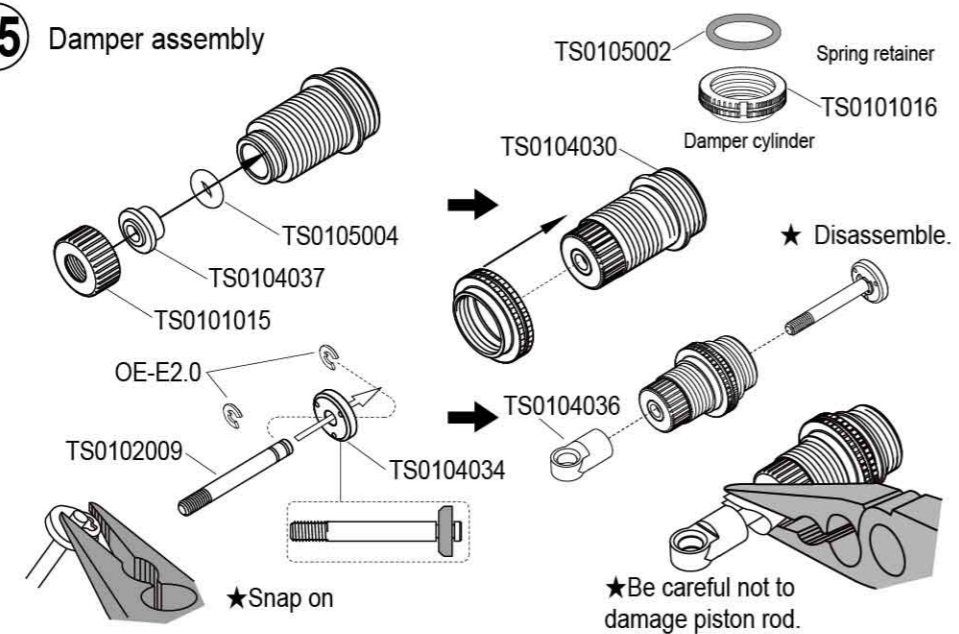

**26** Damper oil



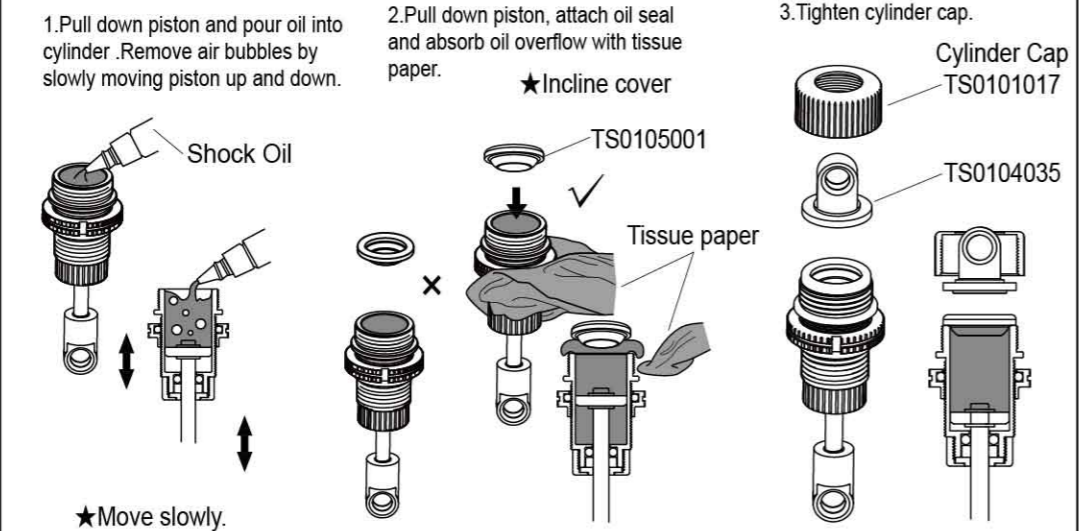



-  TS0105001 .....1

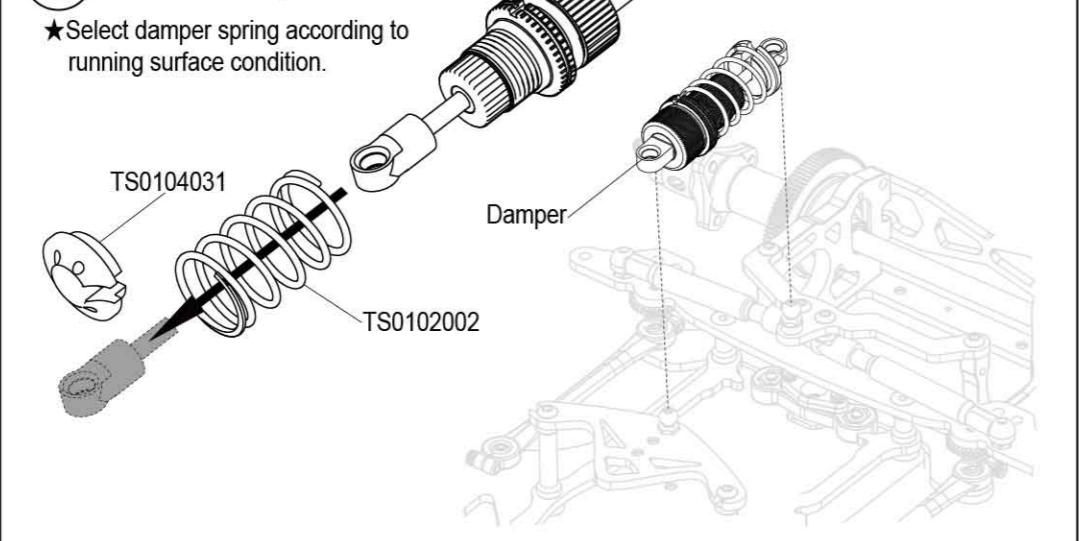



**27** Attaching dampers

-  TS0102002 .....1



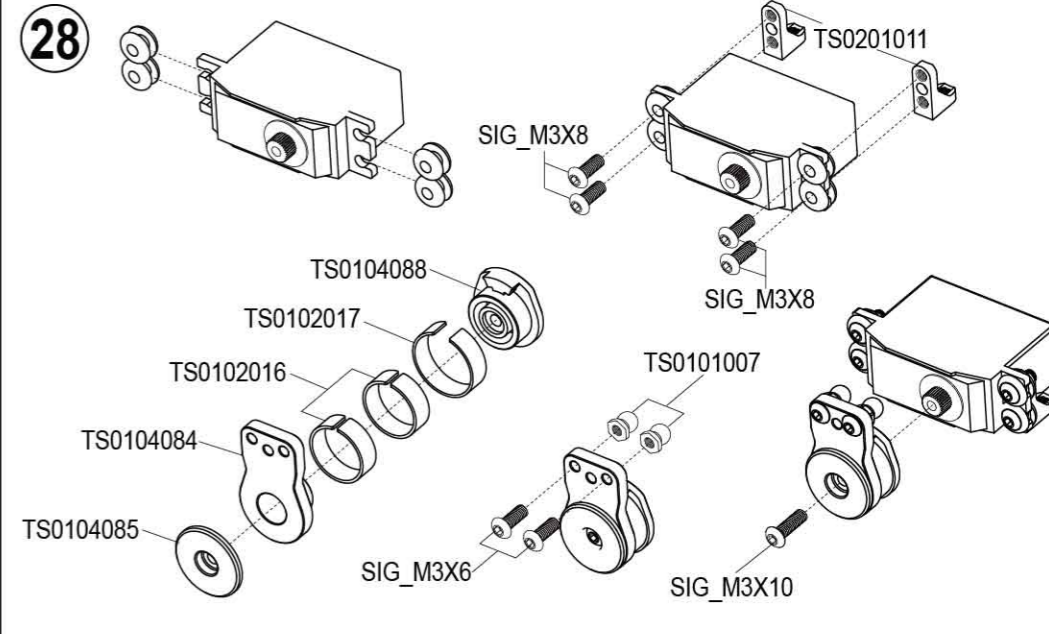

-  TS0201011 .....2
-  TS0102017 .....1
-  TS0102016 .....2
-  SIG\_M3X6 .....2
-  SIG\_M3X8 .....4
-  SIG\_M3X10 .....1

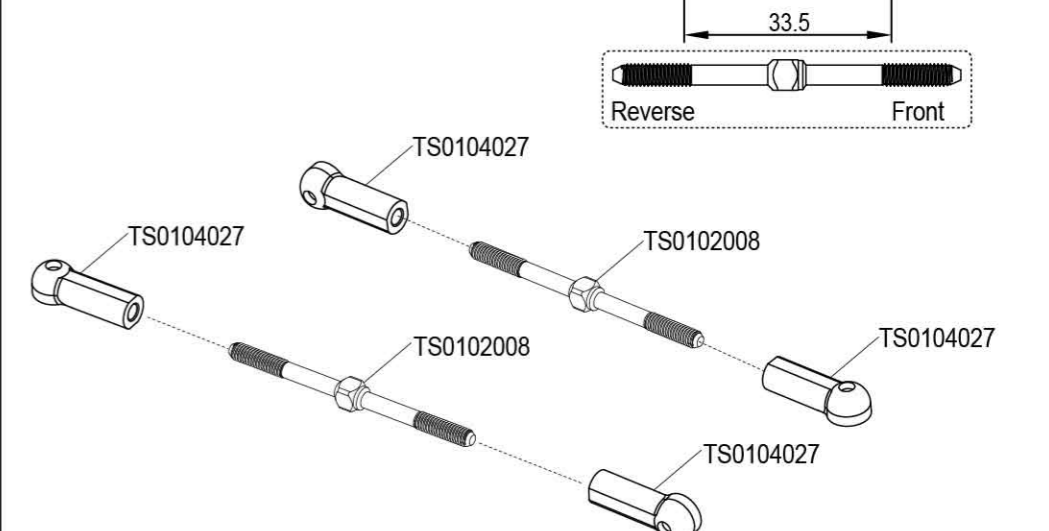

-  L=45.7mm  
TS0102008 .....2
-  TS0104027 .....4

**29** Servo saver



-  SJG\_M3X6 .....2

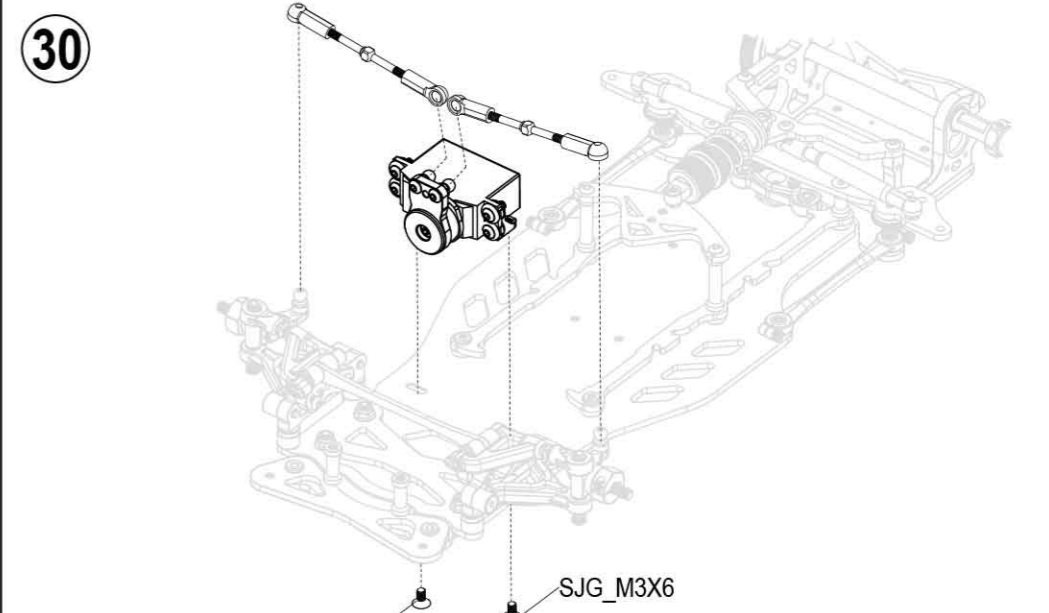

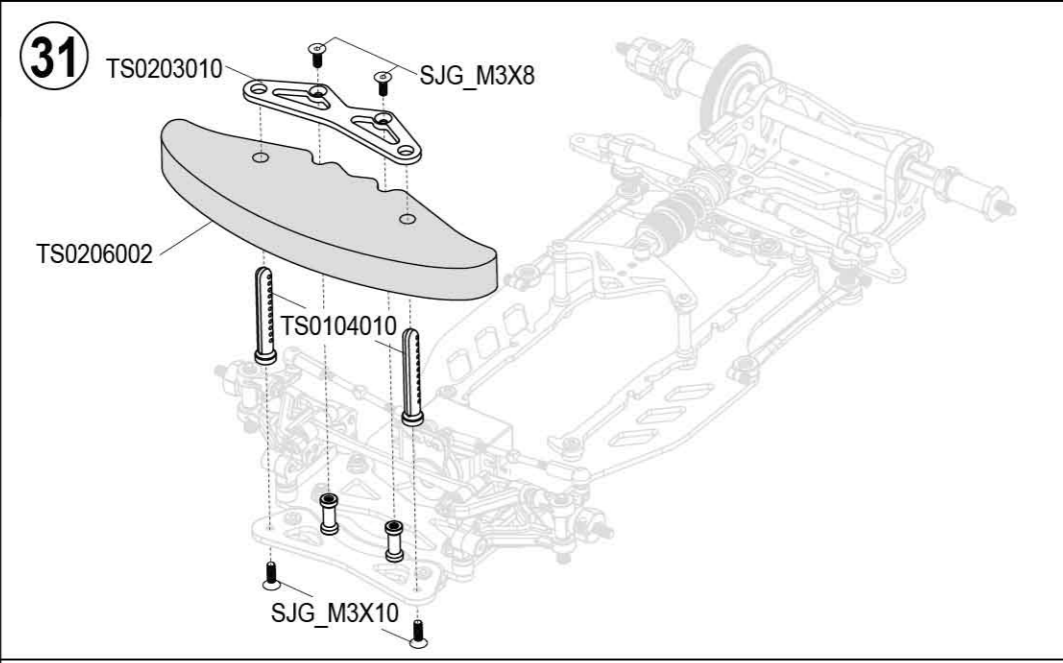

- TS0104010 .....2
- SJM3X10.....2
- SJM3X8 .....2

- TS-P034\_R6.....4
- TS0104003 .....2

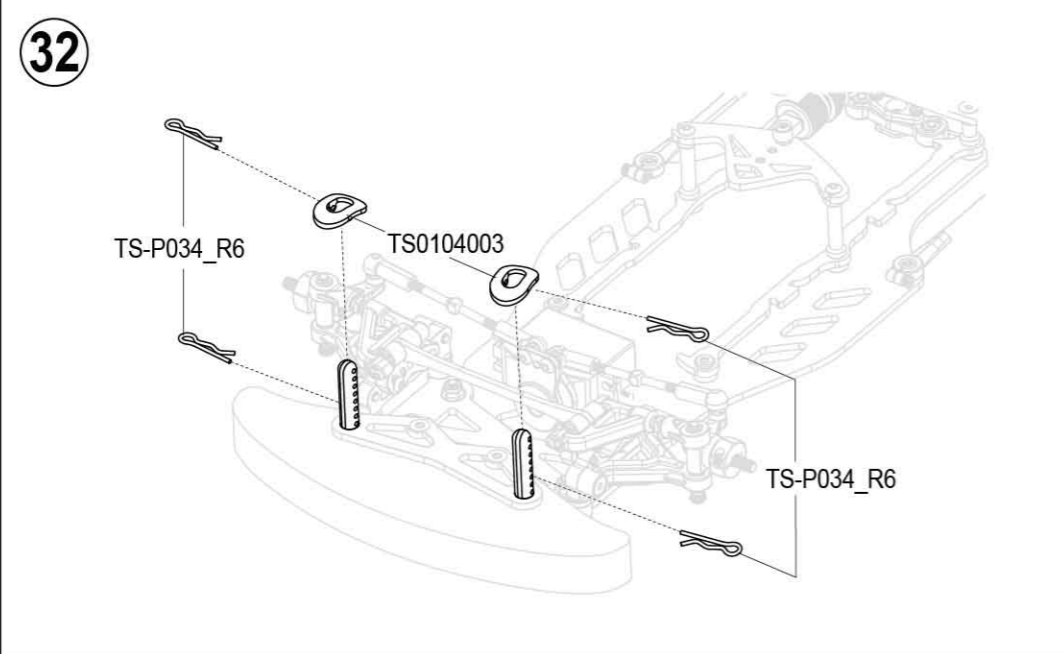

- SIG\_M3X8 .....6
- TS0104007 .....2
- L=40mm TS0201028 .....2

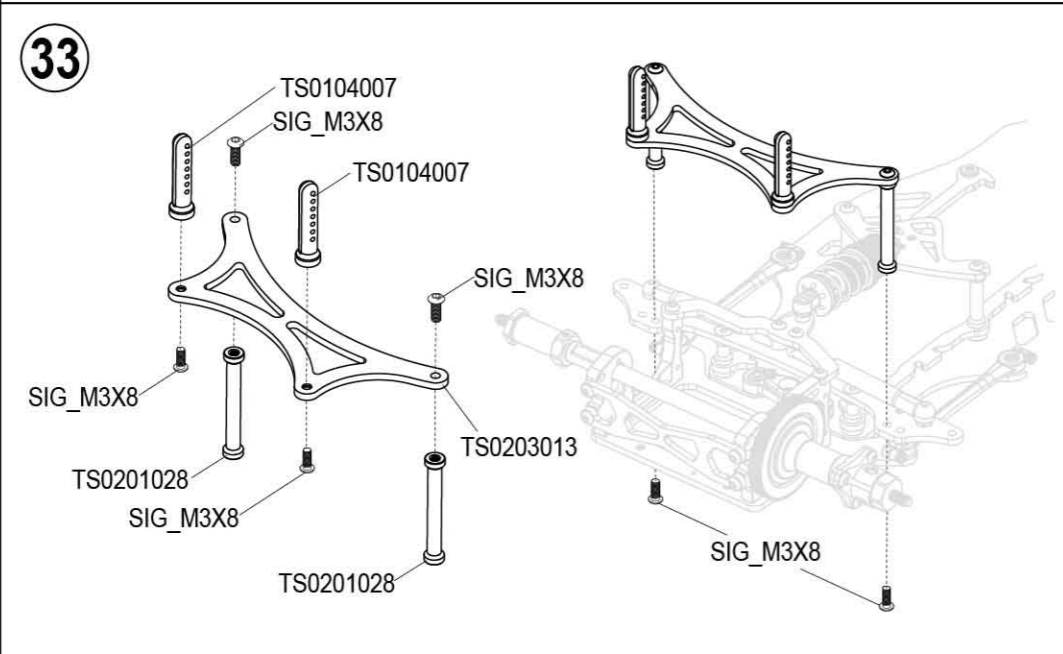

- TS-P034\_R6 .....2
- TS0104003 .....2

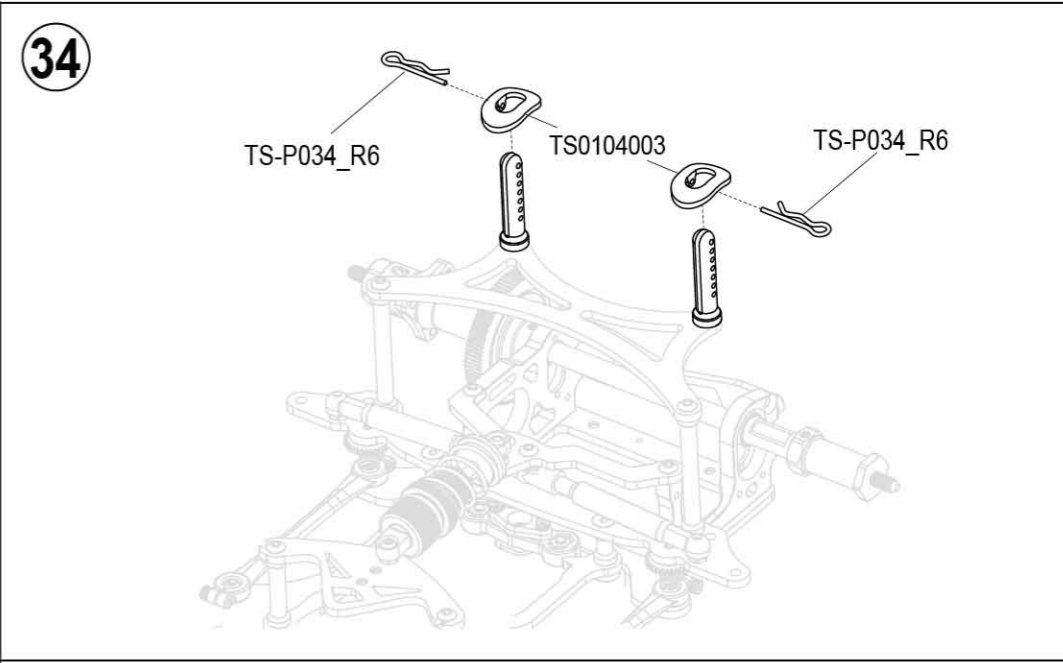

- SJM3X6 .....2

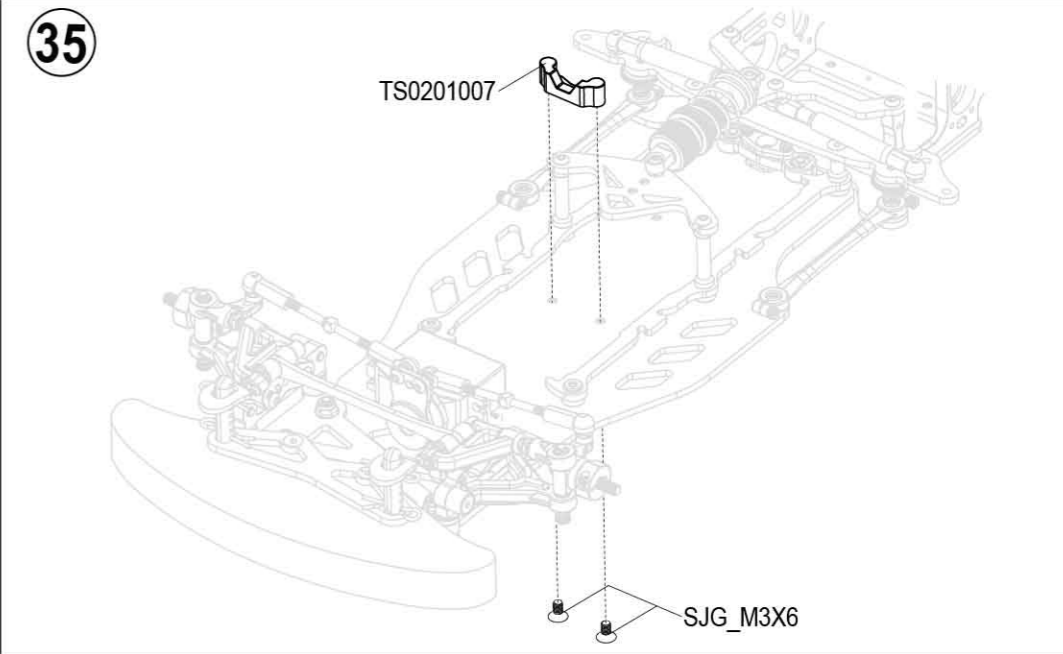

- SN\_M4-F .....2

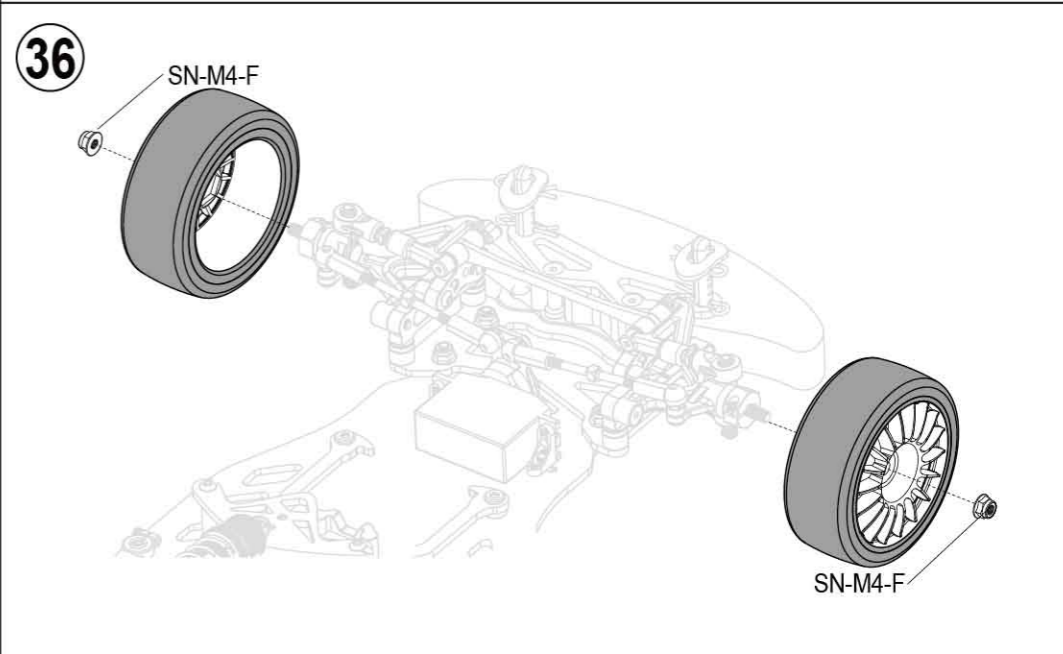

SN\_M4-F .....2

37

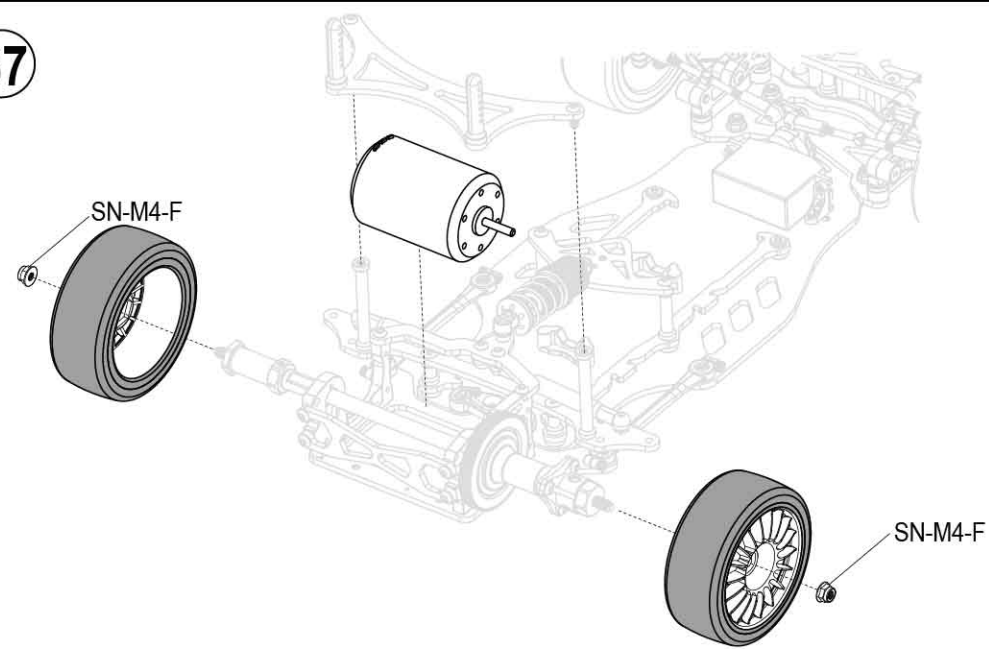

38 2S Standard battery assemble as below

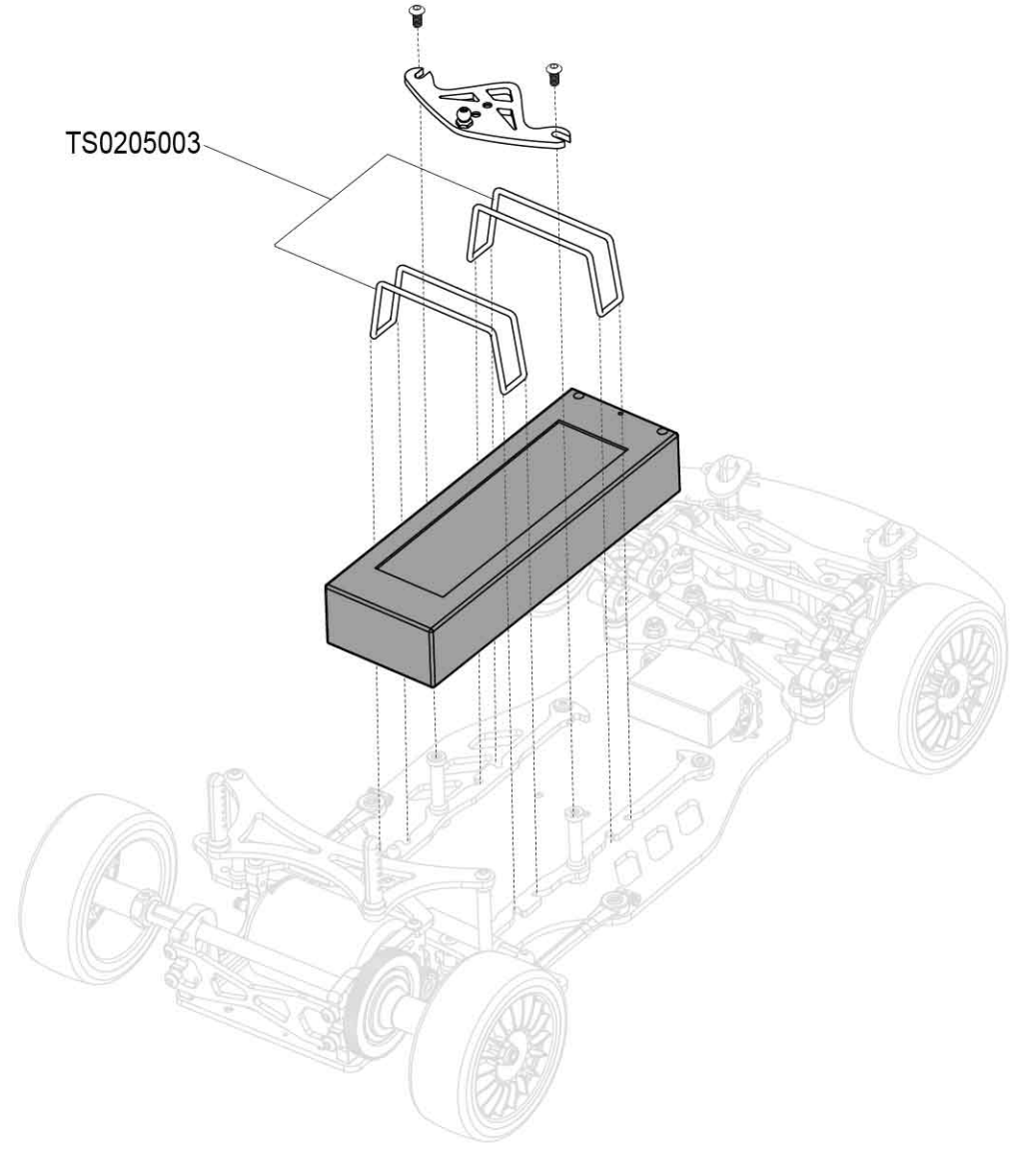
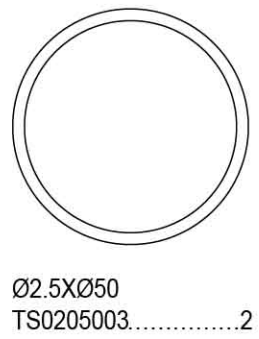

TS0201007.....1

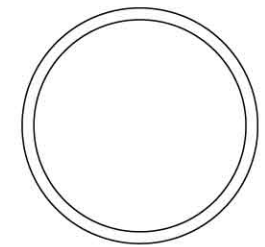

Ø2.5XØ50  
TS0205003.....1

SJG\_M3X6 .....2

39 2S Short battery assemble in front position

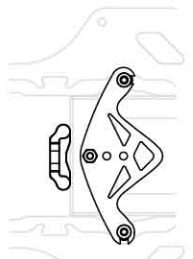
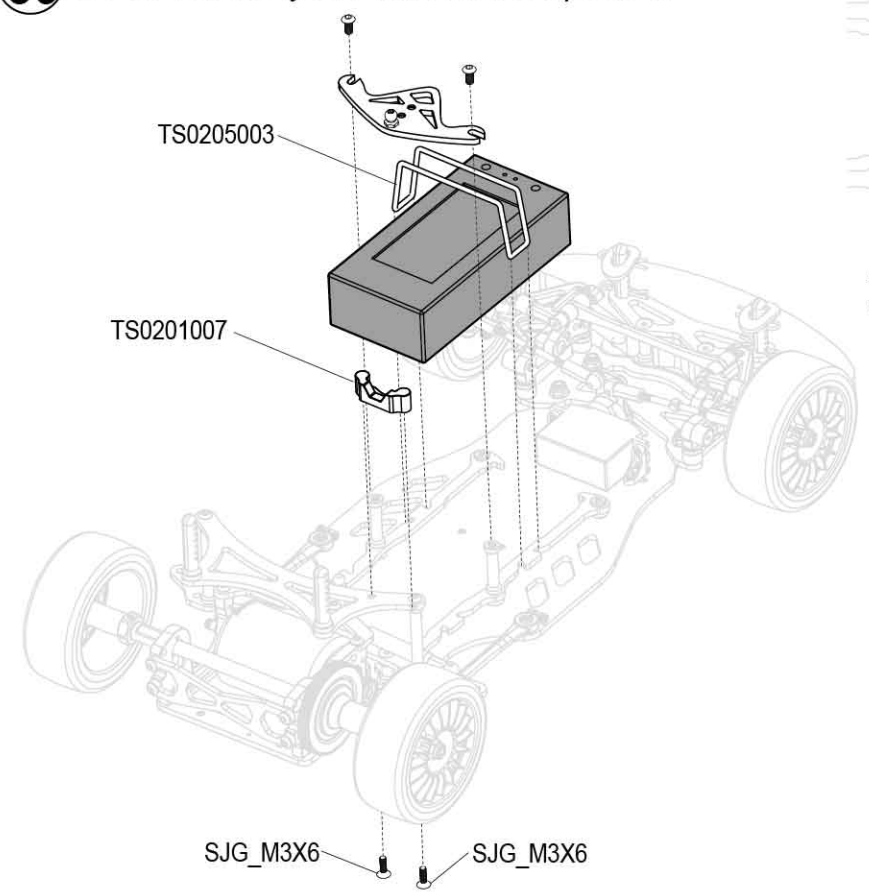

Attention to the direction of block

TS0201007.....1

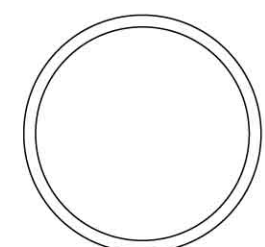

Ø2.5XØ50  
TS0205003.....1

40 2S Short battery assemble in rear position

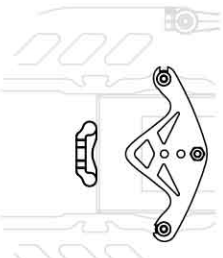
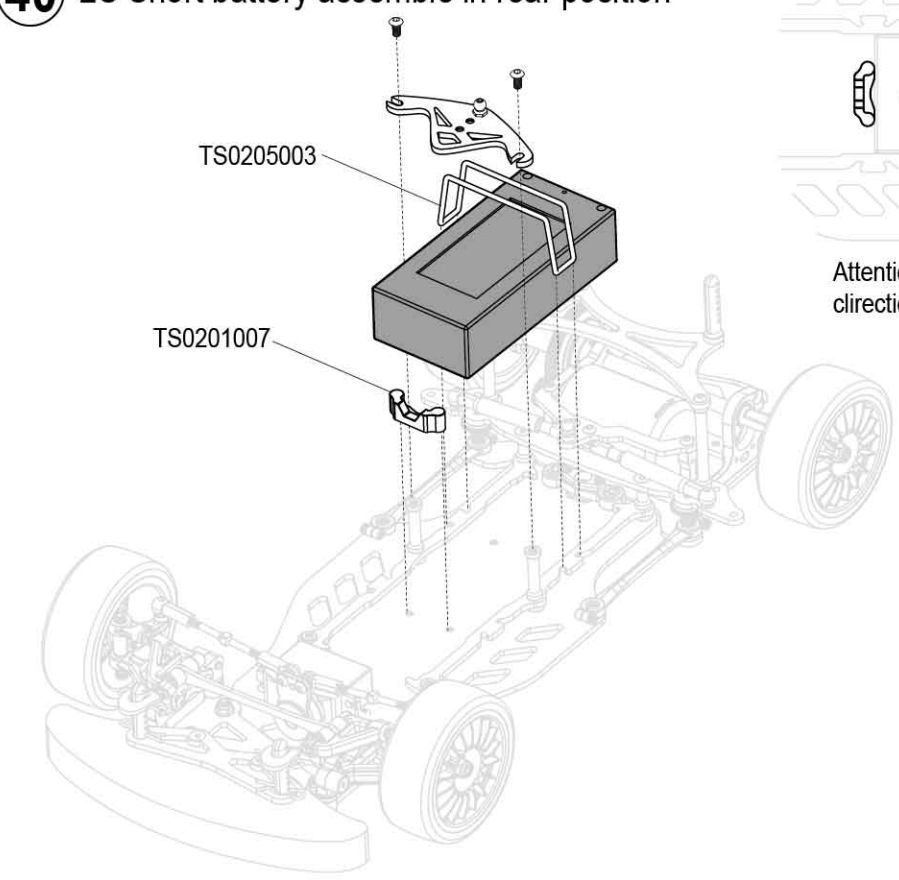

Attention to the direction of block

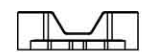

TS0201007.....1

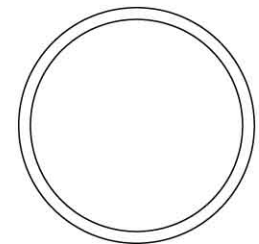

Ø2.5XØ44  
TS0205002.....1

### 41 1S Battery assemble in front position

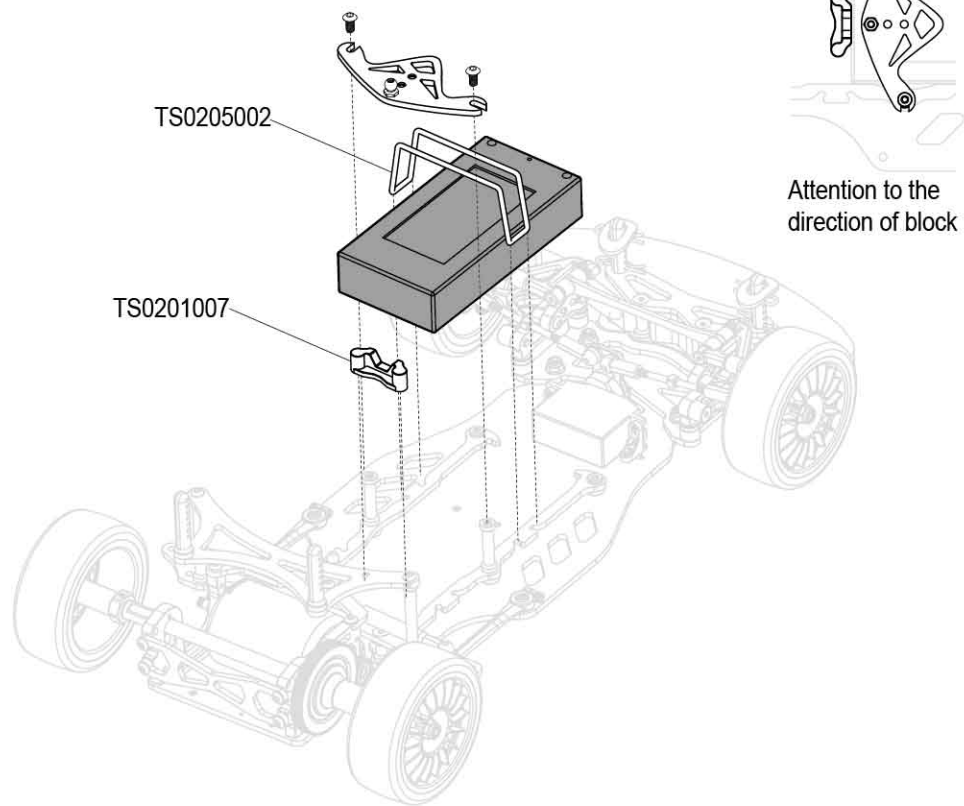

TS0201007.....1

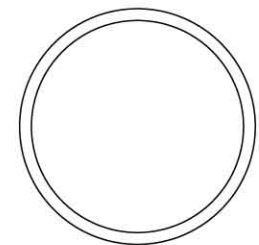

Ø2.5XØ44  
TS0205002.....1

### 42 1S Battery assemble in rear position

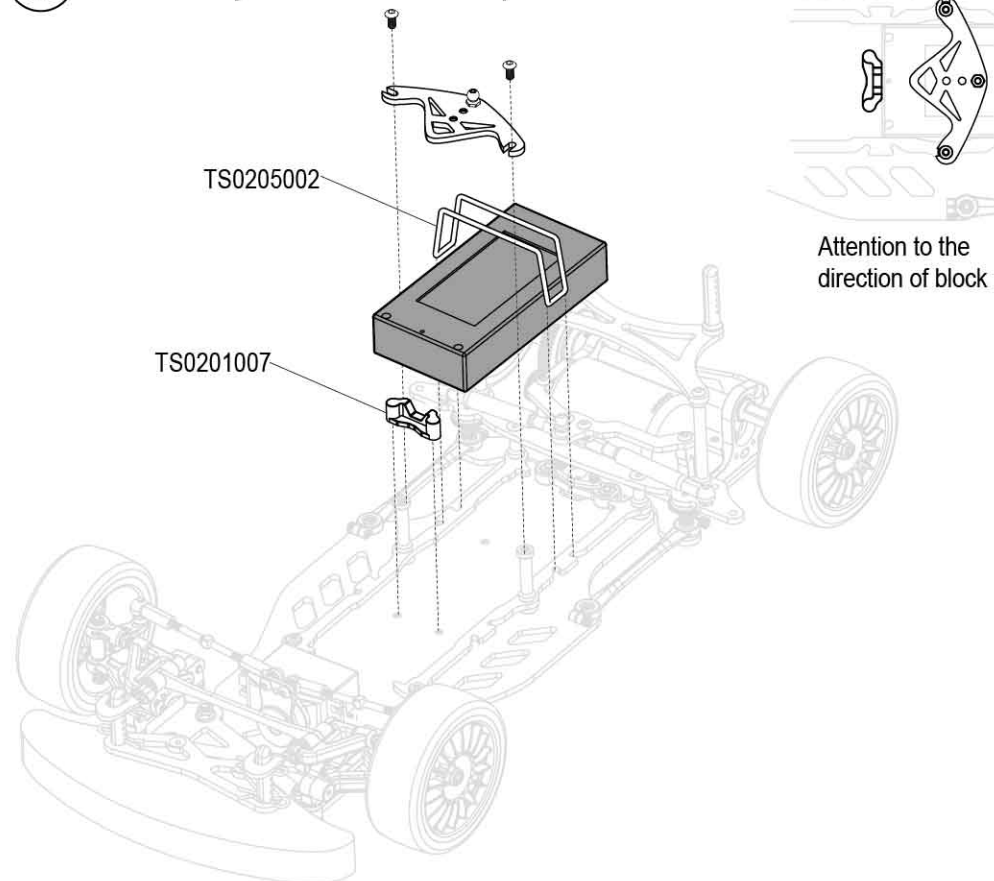

## SETTING - UP

- Record various running conditions and settings on the setting sheet on page 16.

### TOE-IN AND TOE-OUT

Toe-in and toe-out

- Adjust rod length by rotating adjuster.
- Make sure the servo is in neutral.

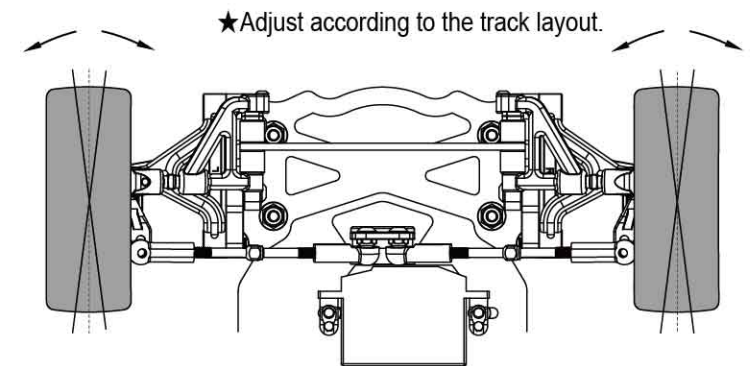
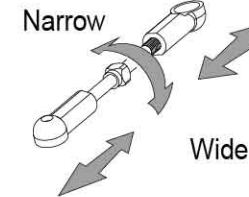

### CAMBER ANGLE

Camber angle

- Adapt for the draw bar to adjust camber angle.

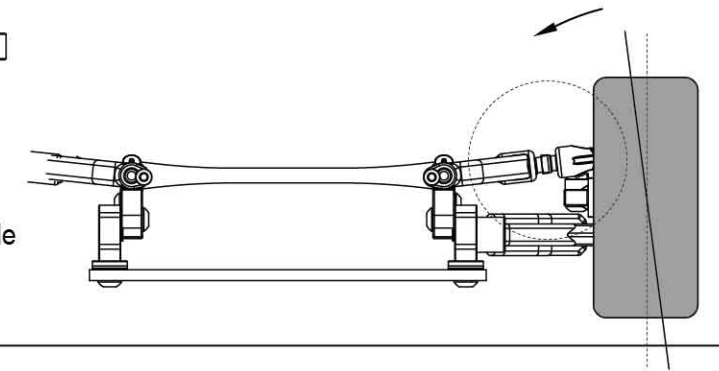
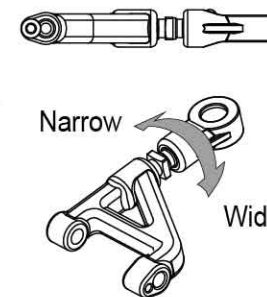

### GROUND CLEARANCE

Front

- Ways for adjusting the turnbuckle to fit the hardness of the front suspension

