

Driver	
Date	



# SET-UP SHEET V2

## AVID

<b>Track</b>			
Location			
Condition	Asphalt	Carpet	Other:
Size	Technical	Mixed	Fast
Traction	Low	Medium	High
Temperature	Air:	Track:	

<b>Adjustments</b>		<b>Front</b>				<b>Rear</b>							
Camber (°)													
Caster (°)		2	3	4	5	Other:							
Toe (°)													
Ride height (mm)													
Suspension mount (°)		FF:				FR:		RF:			RR:		
Rollcenter (mm) FF		0	1.5	2.5	Other:								
Rollcenter (mm) FR		0	1.5	2.5	Other:								
Wheelbase (mm)		+2	+1	0	-1	-2	Other:						
Droop (mm)													
Transmission		Oneway		Spool		Diff							
Anti-Roll Bar		None	mm				Color:	None	mm			Color:	

<b>Shocks</b>													
Spring													
Preload (mm)													
Oil													
Piston		2 holes			3 holes			Other:					
		2 holes			3 holes			Other:					

<b>Shock Position</b>															
Arm		1	2						1	2	3				
Tower		1	2	3	4	5	6	7	1	2	3	4	5	6	7

<b>Upper Suspension</b>														
Washer Inboard (mm)														
Hole Suspension Plate		A	B	C	D	E	F	A	B	C	D	E	F	
Washer Rear Hub (mm)														
Hole Rear Hub		G			H			I						

**Comments**

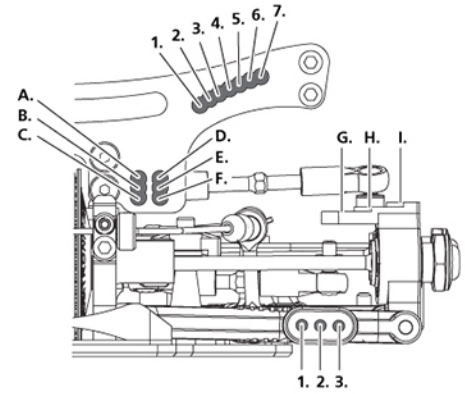
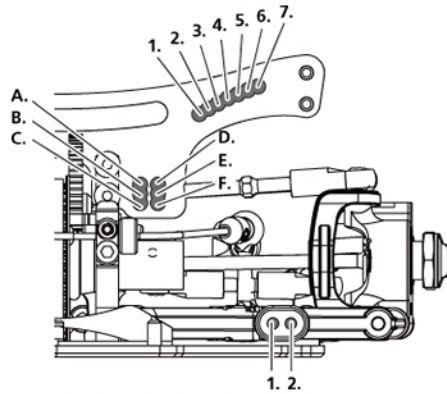

<b>Steering</b>						
Ball End - Position Steering Plate		1	2	3	4	5
Position Knuckle Arms		1	2			
Washer under Ball End Knuckle (mm)						

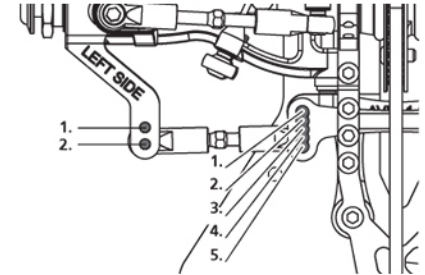

<b>Tires</b>			
Tire			
Insert			
Rim			
Additive			

<b>Chassis</b>			
Low Desk		2.5mm	3.0mm
Top Desk		2.0mm	2.5mm

<b>Motor &amp; Battery</b>		<b>Transmission (IR:1.77)</b>			
Motor		Pinion			
Timing		Spur			
Brush		Ratio			
Battery		Pitch	48DP	64DP	

<b>Body &amp; Wing</b>			
Body			
Wing			

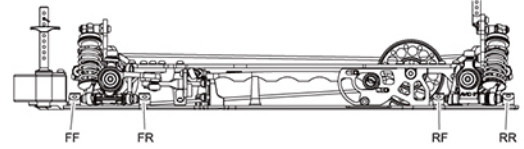

**Comments**