

ROBITRONIC Avid

POWER FOR WINNERS

Set-Up Ludo Bangkok, Thailand

SET-UP SHEET

DRIVER	Ludovic LEFLON
DATE	July 2007

TRACK:				
RACE	LOCATION	RC Speedway and FRC Bangkok, Thailand		
TRACK CONDITION	CARPET	ASPHALT		
TRACK SIZE	TECHNICAL	MIXED		FAST
TRACTION	LOW	MEDIUM		HIGH
TEMPERATURE / °C	AIR	33 °C	TRACK	48 °C

ADJUSTMENT:				
FRONT:				
CAMBER / °degree	2 °			
RIDE HIGH / mm	4 mm			
CASTER / °degree	2°	3°	<input checked="" type="checkbox"/> 5°	
WHEELBASE / mm	+2mm	+1mm	0mm	-1mm -2mm
ROLLCENTER / mm (0, 1,5, 2,5mm)	FF: 1,5 mm	FR: 1,5 mm		
SUSPENSION MOUNT / °degree	FF: 3 °	FR: 3 °		
TOE IN	3,5 °			
TRANSMISSION	<input checked="" type="checkbox"/> ONWAY	<input type="checkbox"/> SPOOL	<input type="checkbox"/> DIFFERENTIAL	
ANTI-ROLL BAR	<input checked="" type="checkbox"/> YES <input type="checkbox"/> NO			
DROOP / mm	? mm			
REAR:				
CAMBER / °degree	3 °			
RIDE HIGH / mm	4 mm			
WHEELBASE / mm	+2mm	+1mm	0mm	-1mm -2mm
ROLLCENTER / mm (0, 1,5, 2,5mm)	RF: 1,5 mm	RR: 1,5 mm		
SUSPENSION MOUNT / °degree	RF: 0°	RR: 2,5 °		
ANTI-ROLL BAR	<input type="checkbox"/> YES <input checked="" type="checkbox"/> NO			
DROOP / mm	? mm			

SHOCKS:	
FRONT:	
SPRING	Tamiya Yellow
PRELOAD / mm	4t
SHOCK OIL	LRP 40w
PISTON	2 HOLES <input checked="" type="checkbox"/> 3 HOLES
REAR:	
SPRING	Tamiya Red
PRELOAD / mm	4t
SHOCK OIL	LRP 40w
PISTON	2 HOLES <input checked="" type="checkbox"/> 3 HOLES

TRANSMISSION:	
SPUR GEAR / T	90 T
PINION / T	26 T
PITCH	<input checked="" type="checkbox"/> 48dp <input type="checkbox"/> 64dp
DRIVE RATIO	0 - 19

CHASSIS:	
LOWER CHASSIS PLATE	<input checked="" type="checkbox"/> 2,0mm <input type="checkbox"/> 3,0mm
UPPER CHASSIS PLATE	2,0mm <input checked="" type="checkbox"/> 3,0mm

TIRES:	
TIRE	Tami Sorex 30R 24mm
INSERT	Ride 40 Orange
RIM	Ride 16 spokes
ADDITIVE	Paragon/LRP Asphalt Bk

MOTOR:	
MOTOR	Orion KATANA
ARMATURE / turns	23 T
BRUSH	Stock
TIMING	locked mm

BODY:	
BODY	Dodge Status III Protoform

COMMENTS:	
Normal wing, tyres warmed at 80°C for 15 minutes before run with Much More CTX-W. Very exciting tracks !	

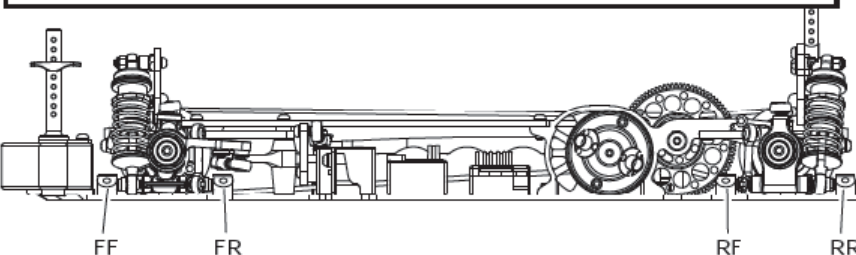

UPPER SUSPENSION FRONT			
WASHER INBOARD / mm	4 mm		
HOLE SUSPENSION PLATE	INNER HOLE	MIDDLE HOLE	OUTER HOLE

SHOCK POSITION FRONT			
A-ARM (1. = INNER HOLE)	1.	<input checked="" type="checkbox"/>	
SHOCK STAY (1. = INNER HOLE)	1.	<input checked="" type="checkbox"/>	3. 4.

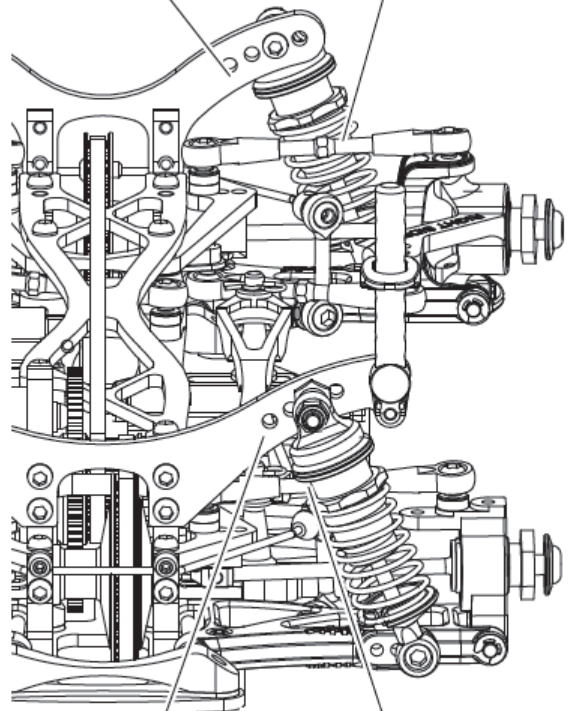

SHOCK POSITION REAR			
A-ARM (1. = INNER HOLE)	1.	2.	<input checked="" type="checkbox"/>
SHOCK STAY (1. = INNER HOLE)	1.	<input checked="" type="checkbox"/>	3. 4.

UPPER SUSPENSION REAR			
WASHER INBOARD / mm	4		
HOLE SUSPENSION PLATE	INNER HOLE	MIDDLE HOLE	OUTER HOLE
WASHER REAR HUB / mm	2		
HOLE REAR HUB	INNER HOLE	MIDDLE HOLE	OUTER HOLE

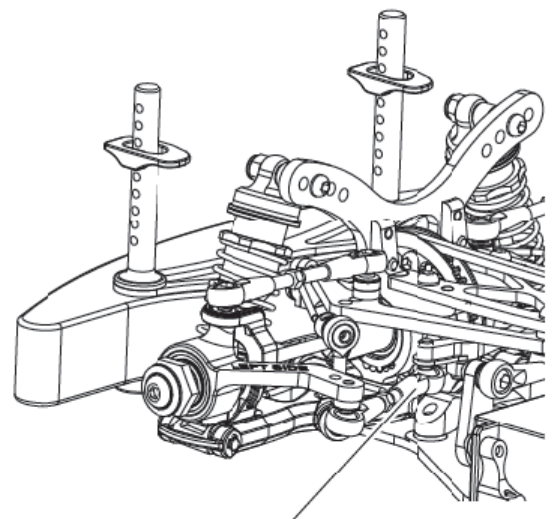

STEERING:		
BALL END - POSITION KNUCKLE	FRONT HOLE	REAR HOLE
WASHER UNDER BALL END KNUCKLE	2 mm	
WASHER UNDER BALL END STEERING PLATE	0 mm	