

Driver: \_\_\_\_\_

Date: \_\_\_\_\_

Tracks: \_\_\_\_\_

Events: \_\_\_\_\_

Conditions: \_\_\_\_\_

Rev:2

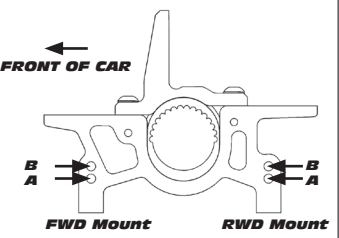
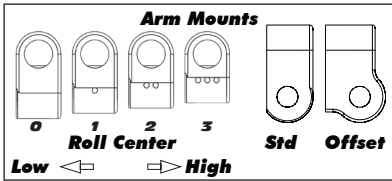
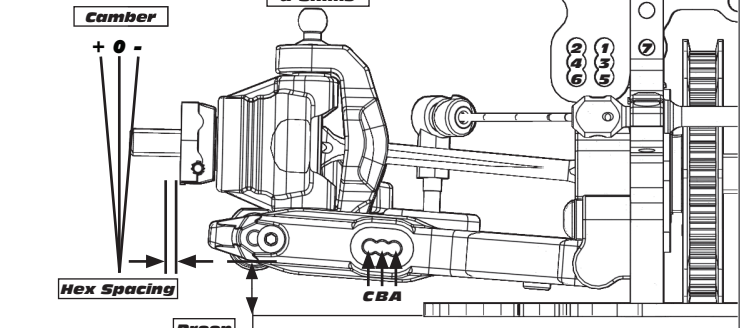
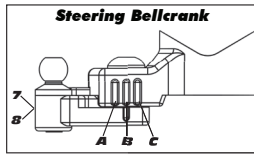
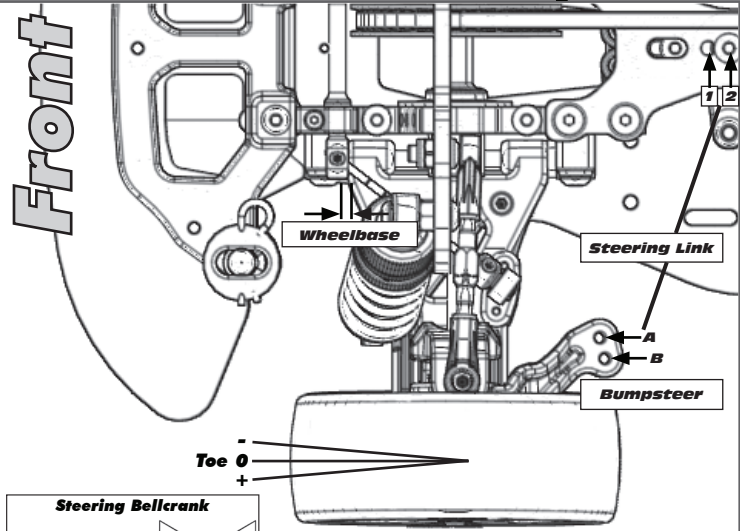

Transmitter	
Turning Circle:	
Steering Expo:	
Brake E.P.:	
Throttle Expo:	
Motor	Gearing
	/
Notes:	Notes:

Speed Control	
E.S.C. Type:	
E.S.C. Settings:	S.W. Ver.
Notes:	Notes:

Front	Alignment	Rear
	Ride Height	
	Camber	
	Caster	N/A
N/A	Rear Hub Toe	
	Toe (Total)	
	Hex Spacing	
	Wheelbase	
	Steering Bellcrank	N/A
	Steering Link	N/A
	Bumpsteer	N/A

Notes:

Suspension Geometry	
	Shock Position
	Camber Link Position
	Inner Ball & Shims
	Outer Ball & Shims
	FWD Arm Mount
	FWD Mount Shim
	RWD Arm Mount
	RWD Mount Shims
	Droop
	Anti-Roll Bar

Notes:

Shocks	
	Oil
	Piston
	Rebound
	Spring

Notes:

Differentials	
	Type
	Setting
	Cam Holder
	Belt Tension Number

Notes:

Tires	
	Type
	Tire Diameter
	Insert & Wheel
	Additive & Amount

Notes:

Chassis	
	Chassis
	Top Plate
Notes:	Notes:

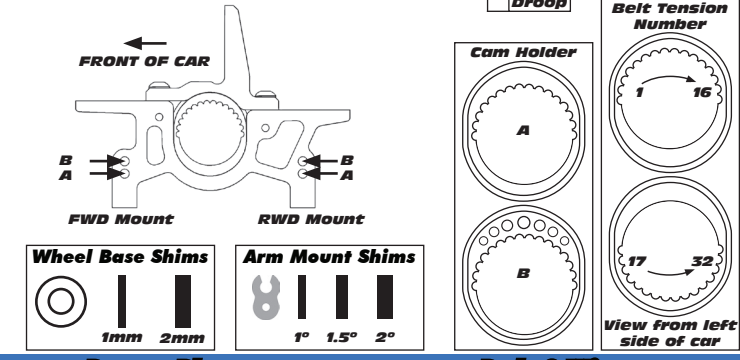
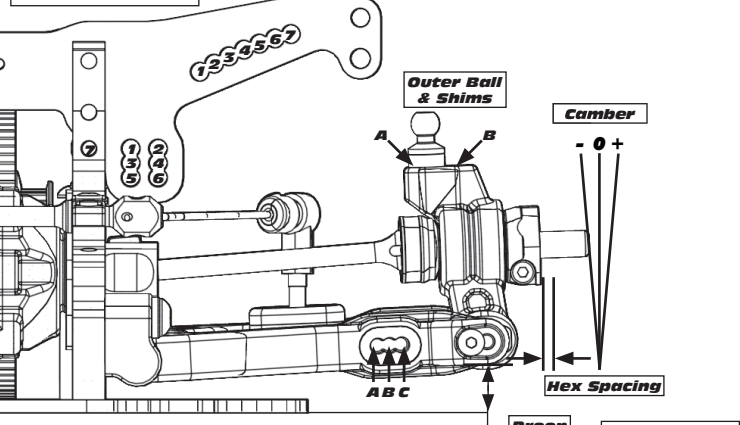
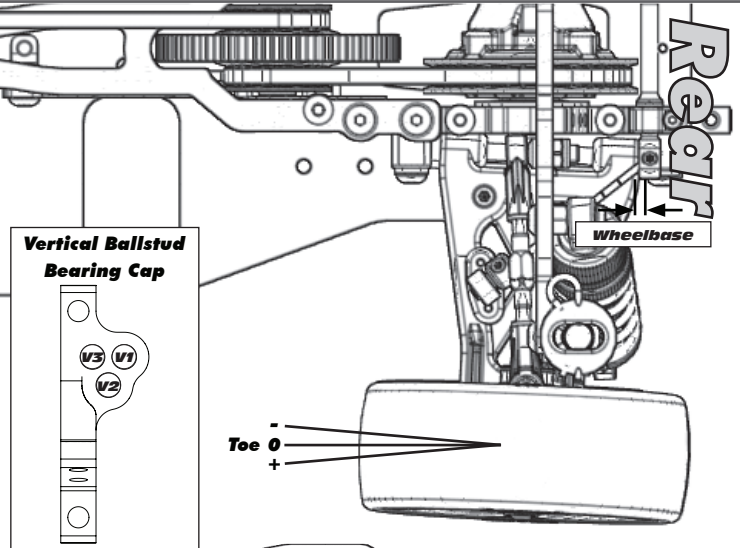

Battery Placement		Body & Wing	
Notes:	Notes:	Notes:	Notes: