

SETUP SHEET



NAME: Brian Stewart
 DATE: Yesterday :)
 EVENT: Boronia Bash VTA
 TRACK: 17.780 Q5 A2 A1 A2 - 2ND
 TRACK CONDITION: Asphalt (Indoor/Outdoor) Carpet
 Technical Mixed Fast
 Low Medium High
 Bumpy Smooth

HUMIDITY: _____ TEMP AIR: _____ TRACK: _____

MOTOR: Team Powers Actinium V2

PIVON: 3.8 FDR SPUR: _____ FITCH: 64

ESC: TEAM POWERS RADON V2

BATTERY: TEAM POWERS 8300 100C

FRONT	SHOCKS	REAR
2.6-2.9 RO	SPRING	2.7-SILV
KIT	PISTON	KIT
550	OIL	550
KIT	LENGTH	KIT
	PRELOAD	
	REBOUND	
<input type="checkbox"/> Yes <input checked="" type="checkbox"/> No	FOAM INSERTS	<input type="checkbox"/> Yes <input type="checkbox"/> No
	O RING ON SHAFT	

KIT ANTIROLL BAR KIT

TIRE: VTA HPI -

RIAM: _____

INSERT: _____

ADDITIVE: USED AOC TYRES -A2 A3 NEW

SURFACE: BITUMEN

PROTOFORM 1969 CAMARO
 TEAM POWERS XPS ESC - V2 ACTINIUM 21.5 - 8300 LIPO - PRIMUS V2 SERVO - 2S X BOOSTER
 ACTIVE REAR SET TO TOE GAIN - ZERO SHIMS. 3.75 STATIC AT RIDE HEIGHT - 4.25 GAIN
 TOO MUCH REAR GRIP IN TIGHT TURNS - VERY PLANTED - ADD .5MM SHIMS TO DIAL GAIN OUT AND TRY 3.5-4 AND 3.5-3.75. ZERO OVERSTEER AFTER WARM UP LAPS.
 BETTER GRIP THAN CARPET AT AOC RAS SHOCKS WORKED WELL BUT HAD AIR BY FINALS. REAR SPUR GEAR MOUNT SCREWS REMOVED - LOCTITE TOP DECK, MOTOR MOUNT AND SPUR GEAR MOUNT SCREWS - KIT PLASTICS THROUGHOUT - DREMELLED C HUB MOD (PORTELLI SHEETS) XRAY DIFF

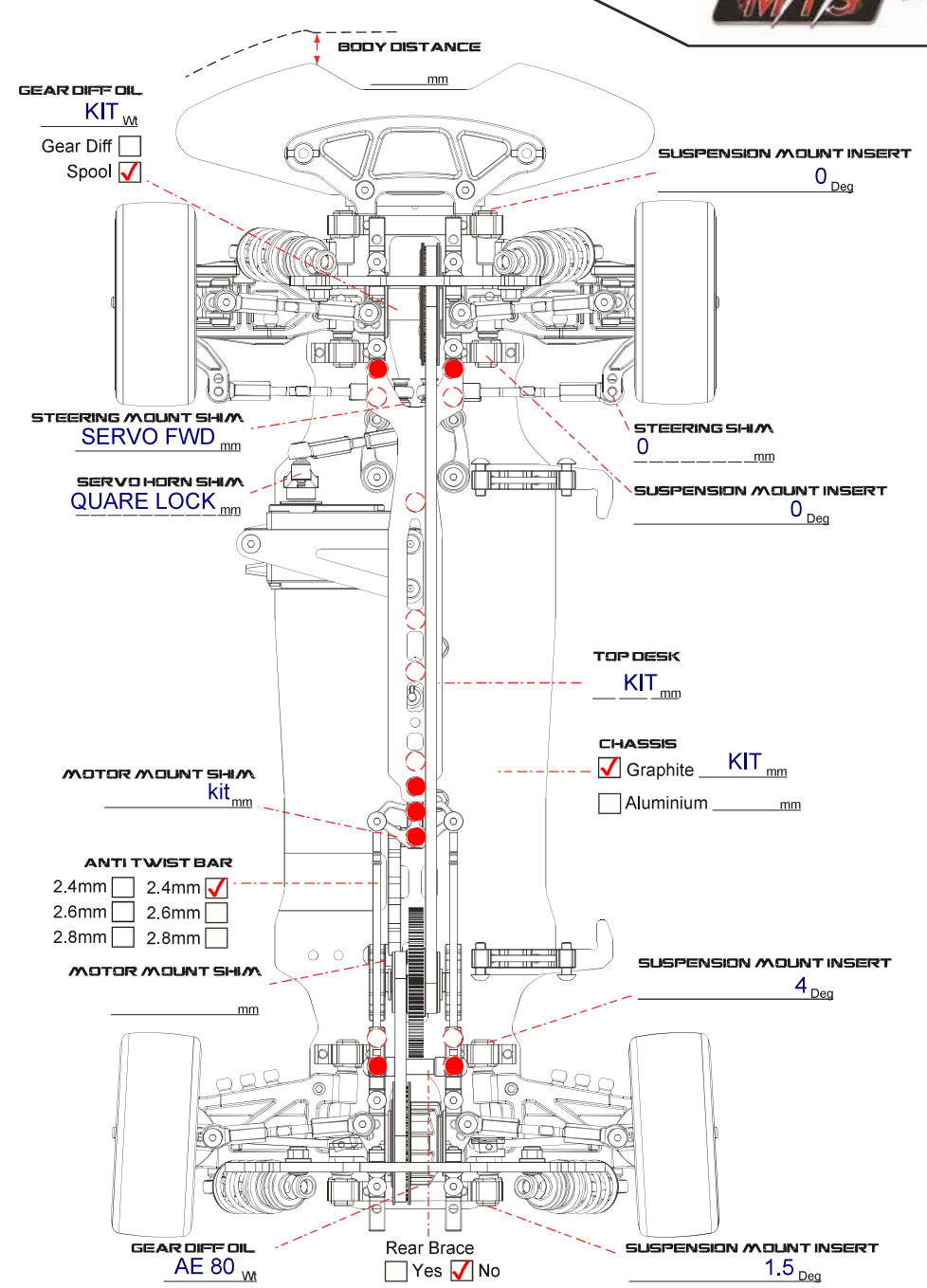
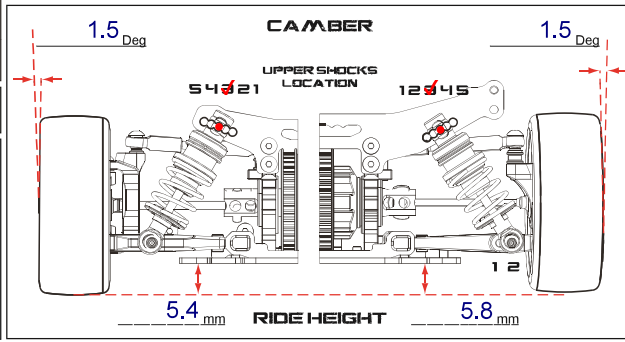
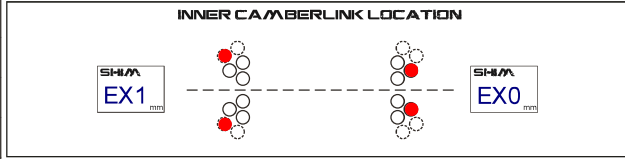
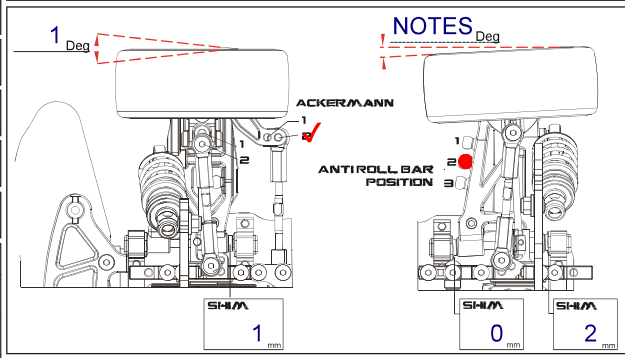
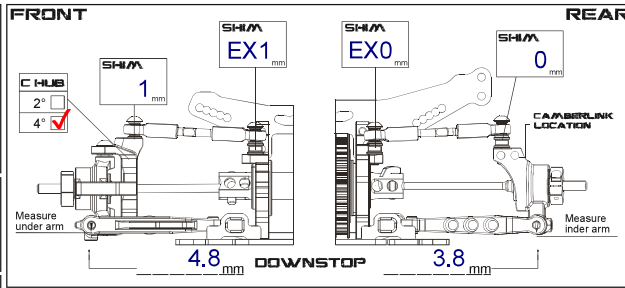

Arno / PetitRC.com

