

NAME			
DATE			
TRACK			
RACE			
TRACK CONDITION	<input type="checkbox"/> CARPET	<input type="checkbox"/> ASPHALT	
	<input type="checkbox"/> INDOOR	<input type="checkbox"/> OUTDOOR	
	<input type="checkbox"/> TECHNICAL	<input type="checkbox"/> MIXED	<input type="checkbox"/> FAST
	<input type="checkbox"/> LOW	<input type="checkbox"/> MEDIUM	<input type="checkbox"/> HIGH

TEMPERATURE	AIR	TRACK
-------------	-----	-------

MOTOR	TIMING
PINION	SPUR
BATTERY	PITCH
ESC	
BODY	WING

SHOCKS	FRONT	REAR
PISTON		
OIL		
LENGTH (mm)		
REBOUND (%)		
SPRING		
129450 1.4x21x5.0 RD 3.5KG		
129455 1.4x21x5.5 SR 3.0KG		
129460 1.4x21x6.0 YE 2.5KG		
129465 1.4x21x6.5 BL 2.0KG		
129550 1.4x21x5.0 RD 3.5KG		
129555 1.4x21x5.5 SR 3.0KG		
129560 1.4x21x6.0 YE 2.5KG		
129565 1.4x21x6.5 BL 2.0KG		
FOAM INSERTS	<input type="checkbox"/> YES <input type="checkbox"/> NO	<input type="checkbox"/> YES <input type="checkbox"/> NO
O-RING ON SHAFT		

	FRONT	ANTI-ROLL BAR	REAR
NONE	1.2mm		1.2mm
	1.4mm		1.4mm
	1.6mm		1.6mm
	1.8mm		1.8mm
	2.0mm		2.0mm

TIRE									
WHEEL									
INSERT									
ADDITIVE									
TIME									
NOTES									
SURFACE	<table border="1"> <tr> <td>FL</td> <td>FR</td> <td>RL</td> <td>RR</td> </tr> <tr> <td></td> <td></td> <td></td> <td></td> </tr> </table>	FL	FR	RL	RR				
FL	FR	RL	RR						

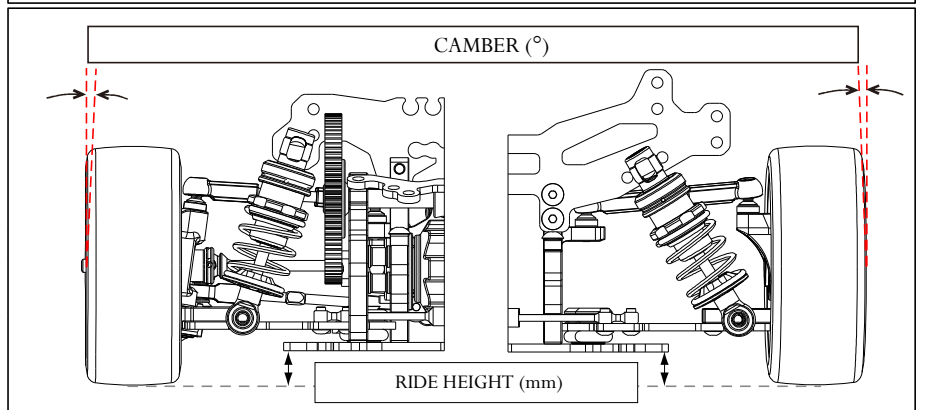
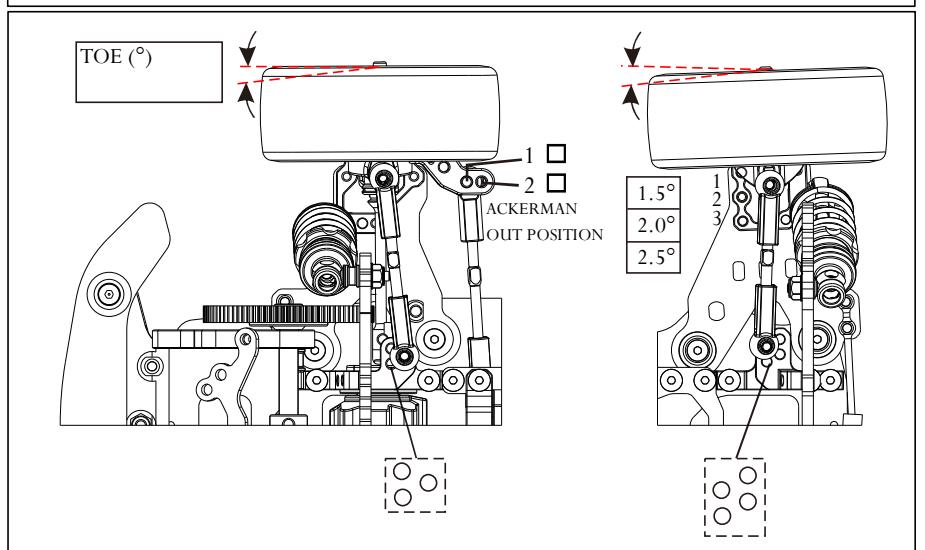
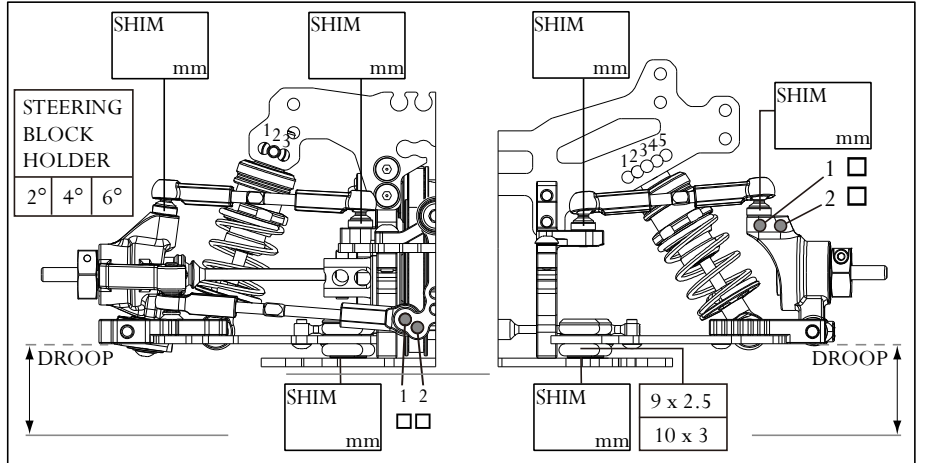

Notes

