

NAME			
DATE			
TRACK			
RACE			
TRACK CONDITION	<input type="checkbox"/> CARPET	<input type="checkbox"/> ASPHALT	
	<input type="checkbox"/> INDOOR	<input type="checkbox"/> OUTDOOR	
	<input type="checkbox"/> TECHNICAL	<input type="checkbox"/> MIXED	<input type="checkbox"/> FAST
	<input type="checkbox"/> LOW	<input type="checkbox"/> MEDIUM	<input type="checkbox"/> HIGH

TEMPERATURE	AIR	TRACK
-------------	-----	-------

MOTOR	TIMING	
PINION	SPUR	PITCH
BATTERY		
ESC		
BODY	WING	

SHOCKS	FRONT	REAR
PISTON		
OIL		
LENGTH (mm)		
REBOUND (%)		
SPRING		
129450 1.4x21x5.0 RD 3.5KG		
129455 1.4x21x5.5 SR 3.0KG		
129460 1.4x21x6.0 YE 2.5KG		
129465 1.4x21x6.5 BL 2.0KG		
129550 1.4x21x5.0 RD 3.5KG		
129555 1.4x21x5.5 SR 3.0KG		
129560 1.4x21x6.0 YE 2.5KG		
129565 1.4x21x6.5 BL 2.0KG		
FOAM INSERTS	<input type="checkbox"/> YES <input type="checkbox"/> NO	<input type="checkbox"/> YES <input type="checkbox"/> NO
O-RING ON SHAFT		

	FRONT	ANTI-ROLL BAR	REAR
NONE	1.2mm		1.2mm
	1.4mm		1.4mm
	1.6mm		1.6mm
	1.8mm		1.8mm
	2.0mm		2.0mm

TIRE				
WHEEL				
INSERT				
ADDITIVE				
TIME				
NOTES				
SURFACE				

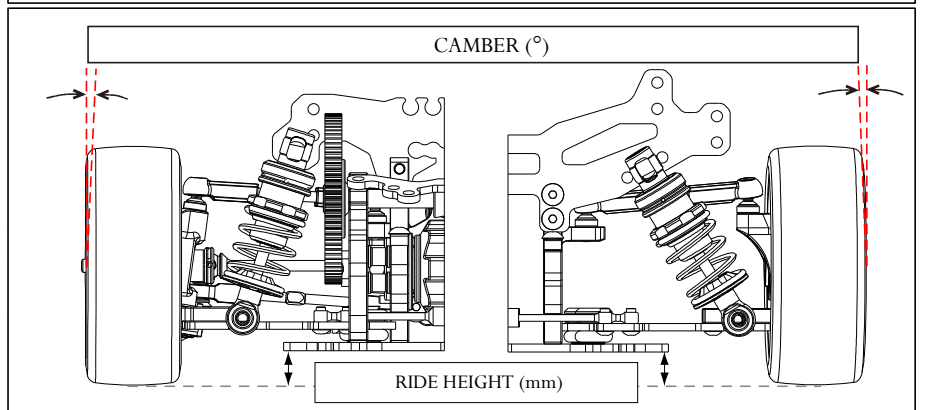
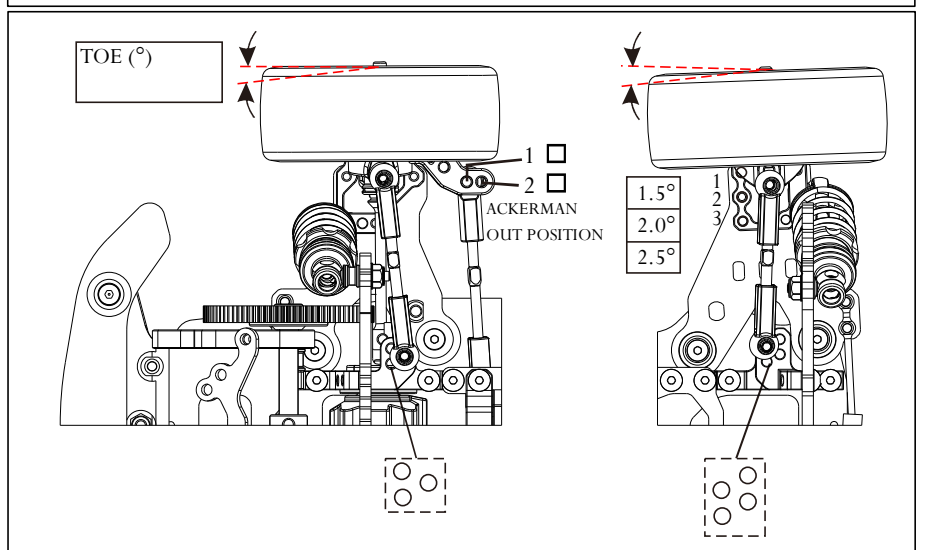
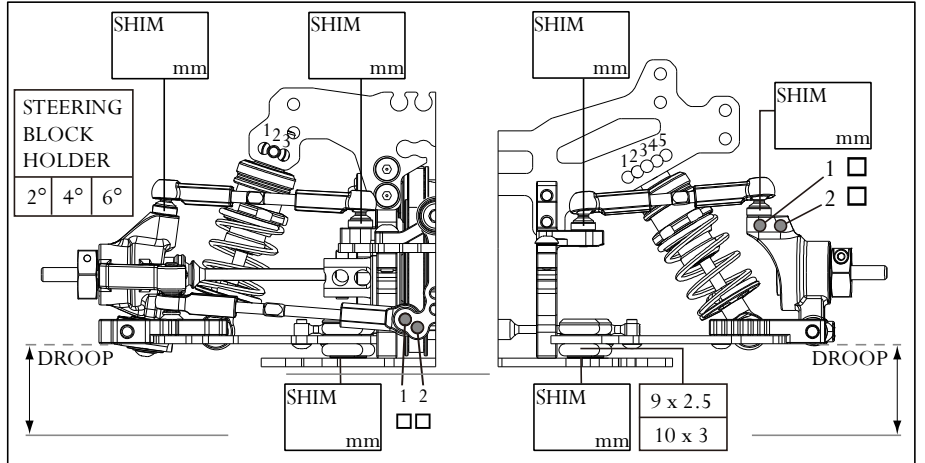

Notes

