

**TRACK CONDITION**

ENVIRONMENT: INDOOR  OUTDOOR   
 COMPOSITION: CARPET  ASPHALT   
 TRACTION: LOW  MEDIUM  HIGH   
 LAYOUT: SLOW  MIXED  FAST   
 SURFACE: BUMPY  SMOOTH   
 NOTE: \_\_\_\_\_

**ELECTRONICS**

MOTOR: *X20 LRP 17,5T* TIMING: *30°Fix*  
 PINION: *38* SPUR: *106*  
 ESC: *LRP Flow X Stock Spec 0,1,0,6,1,0,0,0,0,1*  
 BATTERY: *MuchMore LCG HV 5200*  
 SERVO: *Sanwa 801*  
 RECEIVER: *Sanwa 472*

**SHOCK ABSORBERS**

FRONT REAR  
 PISTON: *4* PISTON: *4*  
 OIL: *550 Hudy* OIL: *550 Hudy*  
 SPRING: *XR 2.5-2.8* SPRING: *XR 2.7*  
 REBOUND: *10%* REBOUND: *10%*  
 NOTE: \_\_\_\_\_

**ANTI-ROLL BAR**

FRONT: 1.2  1.3  1.4  1.5   
 REAR: 1.1  1.2  1.3  1.4

**TIRES & WHEELS**

TIRE: *Volante 28R*  
 INSERT: \_\_\_\_\_  
 WHEEL: \_\_\_\_\_  
 TREATMENT: *CS-High Grip*  
 NOTE: *Test (LRP Carpet 2 & MR33)*

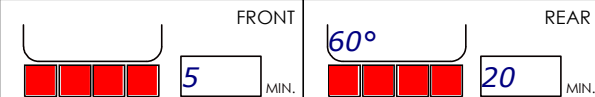

**SERVO SAVER POSITION**



**TRANSMISSION HEIGHT**

SPOOL DIFFERENTIAL  
 HIGH  HIGH   
 LOW  LOW  OIL: *Muchmore 3500*

**FLEX**

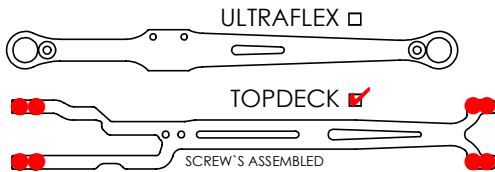

**AERODYNAMICS**

BODY: *HB Subaru C*  
 WING: *KIT*

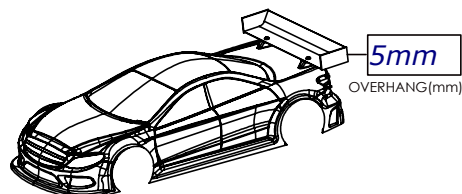

**CASTER POSITION**

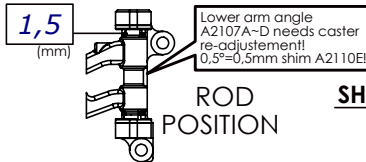

FF: A2105A/A2104  
 1pc. ● 2pcs. ○

FR: A2105B/A2104  
 1pc. ● 2pcs. ○

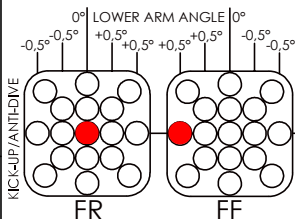

**UPPER ARM POSITION**

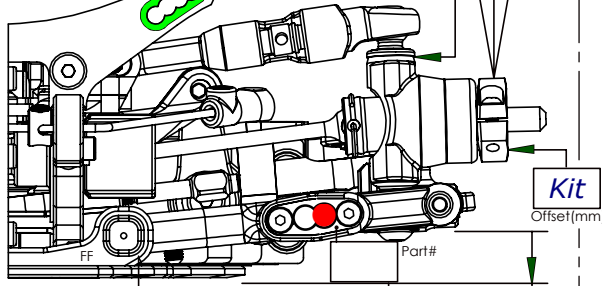
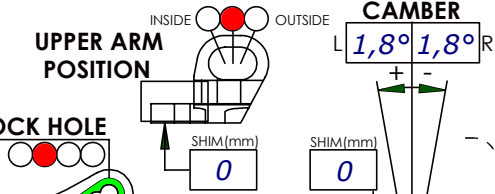

**ROLL CENTER/TRACKWIDTH (LEFT SIDE VIEW)**

RIDE HEIGHT: 5,1 (mm)  
 DOWNSTOP: 5,8 (mm)

**CAMBER LINK POSITION**

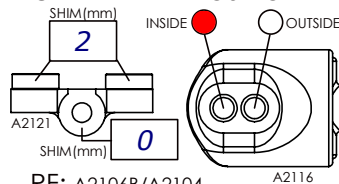

RF: A2106B/A2104  
 1pc. ○ 2pcs. ●

RR: A2106A/A2104  
 1pc. ● 2pcs. ○

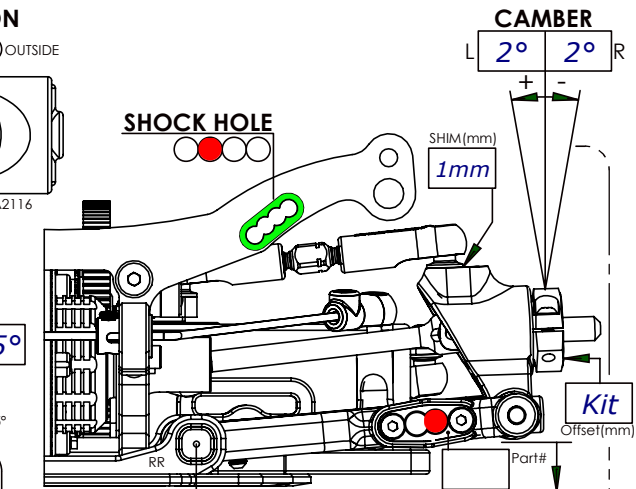
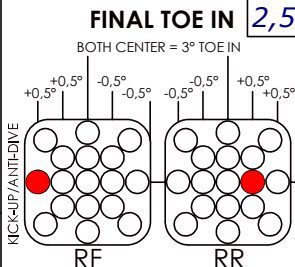

**ROLL CENTER/TOE IN/TRACK WIDTH (RIGHT SIDE VIEW)**

RIDE HEIGHT: 5,2 (mm)  
 DOWNSTOP: 4,8 (mm)

A2404   
 ASSEMBLED SCREW'S

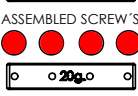

A2405

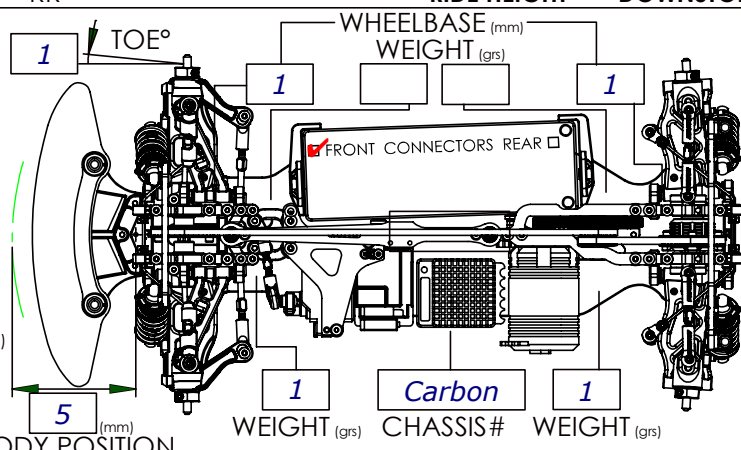
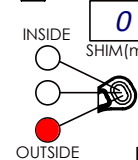

**STEERING SHAFT MOUNTED ON**

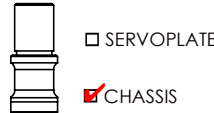

**STEERING STOPPER** A2304/A2305/A2306

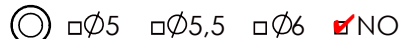

**NOTES:**

*New Black ETS Carpet*