

TRACK CONDITION

ENVIRONMENT: INDOOR OUTDOOR
 COMPOSITION: CARPET ASPHALT
 TRACTION: LOW MEDIUM HIGH
 LAYOUT: SLOW MIXED FAST
 SURFACE: BUMPY SMOOTH
 NOTE: *New ETS black carpet*

ELECTRONICS

MOTOR: *MM 13.5* TIMING: _____
 PINION: *100* SPUR: _____
 ESC: *Muchmore*
 BATTERY: *LRP 6400*
 SERVO: *Highest*
 RECEIVER: *Sanwa 481*

SHOCK ABSORBERS

FRONT REAR
 PISTON: *Std* PISTON: *Std*
 OIL: *550* OIL: *550*
 SPRING: *2.5-2.8* SPRING: *2.7*
 REBOUND: *-* REBOUND: *-*
 NOTE: _____

ANTI-ROLL BAR

FRONT: 1.2 1.3 1.4 1.5
 REAR: 1.1 1.2 1.3 1.4

TIRES & WHEELS

TIRE: *Volante 28R*
 INSERT: *Std.*
 WHEEL: *Std.*
 TREATMENT: *CS High Grip*
 NOTE: _____

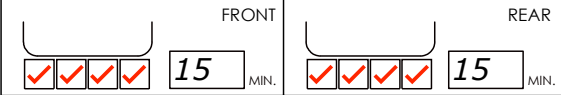

SERVO SAVER POSITION

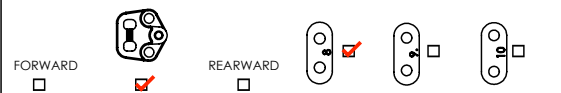

TRANSMISSION HEIGHT

SPOOL DIFFERENTIAL
 HIGH HIGH OIL: *5000*
 LOW LOW

FLEX

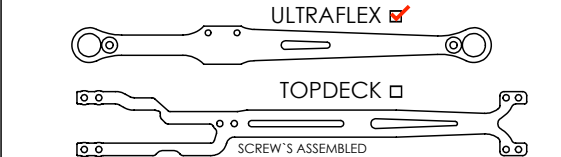

AERODYNAMICS

BODY: *M410 or Madza*
 WING: *MR33*

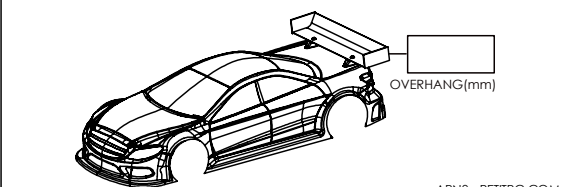

CASTER POSITION

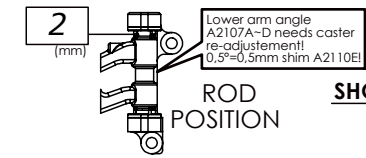

FF: A2105A/A2104
 1pc. 2pcs.
 FR: A2105B/A2104
 1pc. 2pcs.

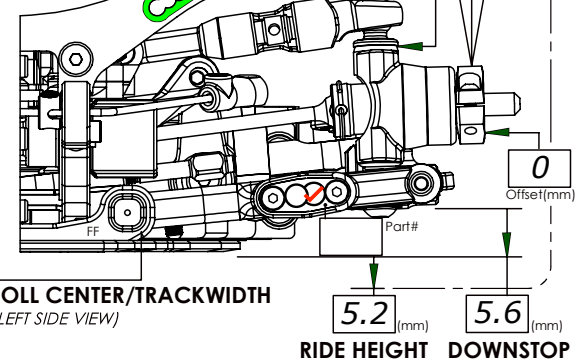
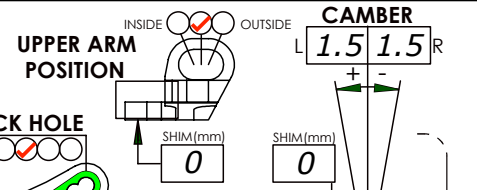
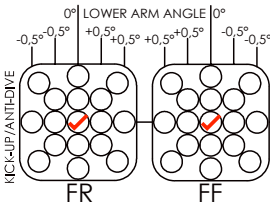

CAMBER LINK POSITION

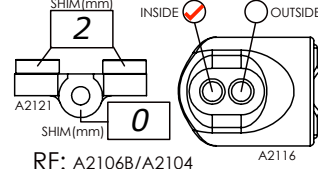

RF: A2106B/A2104
 1pc. 2pcs.
 RR: A2106A/A2104
 1pc. 2pcs.

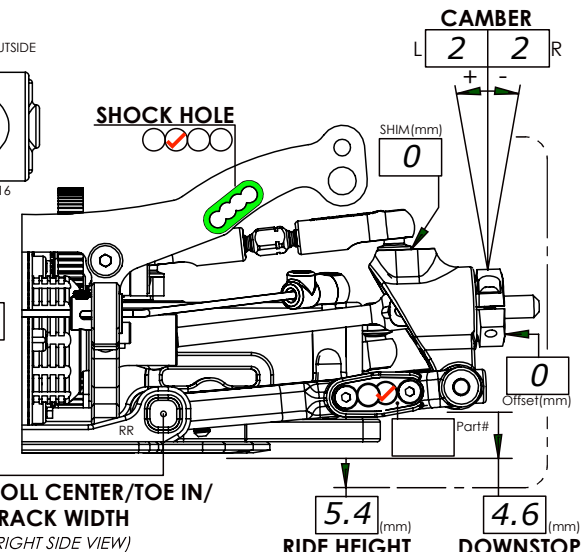
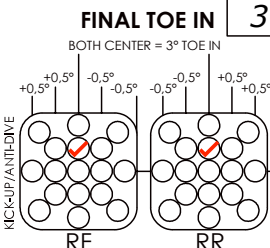

A2404

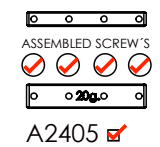

A2405

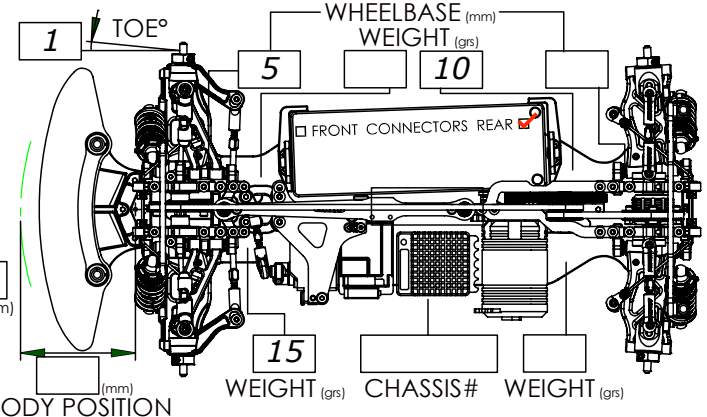
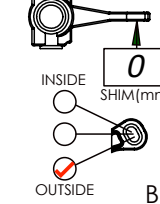

NOTES:
Unstable with LTC-R