

DATE	8/22/2017
DRIVER	Atsushi Hara
TRACK	Bee Tops

CARPET ASPHALT

TRACTION

LOW MEDIUM HIGH

LAYOUT

SLOW MIXED FAST

ELECTRIC'S

STEERING SERVO
TYPE: Futaba
SETTINGS: BLS571SV

ESC
TYPE: Yokomo
BL-PRO4

ENGINE
TYPE: Yokomo
M3 - 17.5T

TYRES/ADDITIVE
TYPE: Rush 36S
MTG V3 Yellow

FRONT FULL MIN. 5
REAR FULL MIN. 5

SHOCK ABSORBERS

FRONT REAR

PISTON Kit PISTON Kit

OIL #450 OIL #450

SPRING Xray 2.6 SPRING Xray 2.6

ANTI ROLL BAR FRONT

1,2 1,3 1,4 1,5

ANTI ROLL BAR REAR

1,1 1,2 1,3 1,4

SERVO SAVER POSITION

FORWARD REARWARD

PINION 38T SPUR 114T

DIFF SPOOL

HIGH LOW

HIGH LOW

DIFF OIL CST #5,000

SHOCK POSITION LOWER ARM

PART# REAR Kit PART# FRONT Kit

HOLE POSITION BALL LINK INSIDE OUTSIDE

HOLE POSITION BALL LINK INSIDE OUTSIDE

FLEX

ULTRAFLEX

TOPDECK

SCREW'S ASSEMBLED

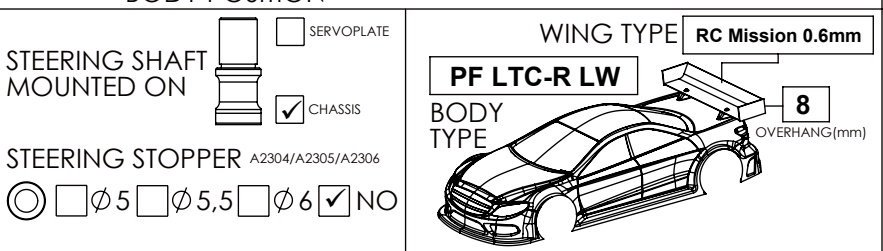
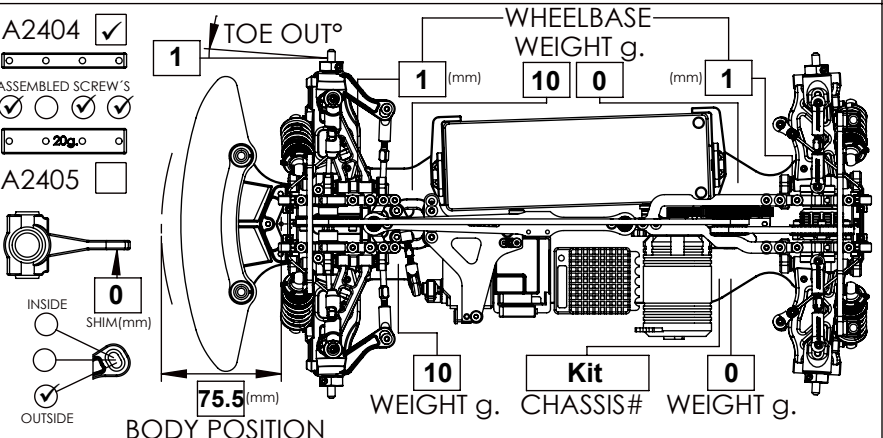
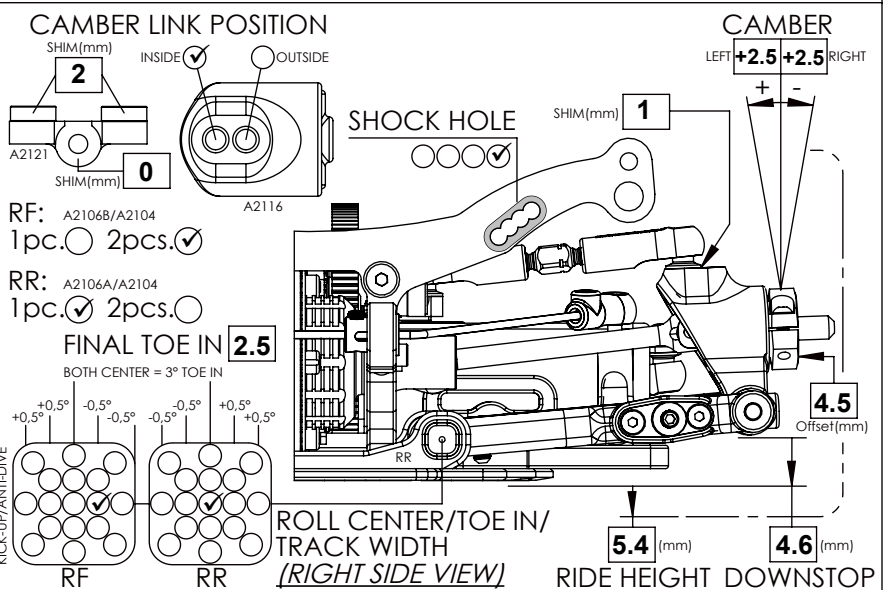
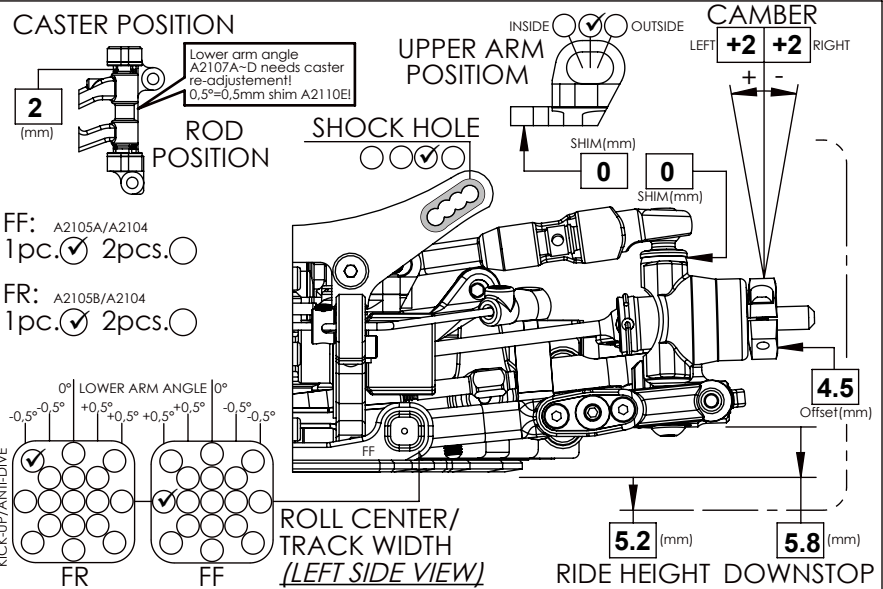

NOTES:

タデフは路面状況により、#3,000~#5,000で調整する。

Adjust the diff oil #3,000~#5,000 depending on the track condition.