

1. Introduction

The MMax Pico sensed Electronic Speed Controller is the ultimate in engineering design from Maclan Racing. Our commitment to quality and exhaustive track testing ensures that the MMax Pro/ ESC gives you the smoothest power band and reliable performance in the most demanding R/C conditions.

Please read the following instructions carefully before installing your new MMax Pro system.

2. Precautions

- For the best performance, we recommend using MMax Pro ESC with Maclan Racing MRR series motors.
- Never operate your MMax Pico ESC without the capacitor module. It will cause permanent damage to the ESC and void factory warranty.
- MMax Pico ESC is a high end racing product that offers many tuning parameters. If you are not well versed in ESC setup, we have numerous factory default profiles to get you started. If you need help with detailed settings, please contact Maclan directly for assistance.
- Never "free rev" and brake the motor and ESC system with no load. It can cause extreme spikes that can damage both the motor and ESC, and moreover, will void the factory warranty.
- Do not connect reversed polarity voltage. This will damage the ESC and void the factory warranty.
- Pay attention to the motor timing. More timing will generate more heat on both the ESC and the motor.
- Do not leave batteries plugged into the ESC when not in use. This will prevent short circuits and over discharging of the battery.
- Always monitor both the ESC and motor temperature after running them. Temperature should never exceed 180 degrees Fahrenheit.

3. Features

- High performance 32-bit CPU for high speed and accurate processing.
- New generation firmware algorithms for the strongest ever throttle and brake performance.
- On board USB host for the ease of connectivity and unlimited extensibility.
- Dual "power-on" options for the ease of operation. (can be controlled by a switch or direct to battery)
- All aluminum structure with omnidirectional heatsink for maximum airflow and optimum cooling performance.
- All detachable connectors with several optional length cables.
- Low weight and low center of gravity structure design.
- Adjustable throttle and brake PWM frequency for fine tuning.
- 8 profiles available for on road and off road applications.
- Motor/ESC temperature protection and low voltage protection.
- MS Windows compatible software for data logging, programming.

4. Specifications

Scale: 1/10th Brushless Sensored/Sensorless ESC
Continuous Current: 100A
Power input: 2S Li-Po
BEC output: Linear Mode 8V to 7.4V, 4A
Wire input: Black-13AWG-200mm*2
Wire output: Black-13AWG-200mm*3
Cooling Fan: 30x30x10mm HV (Optional)
Motor: Brushless Sensored/sensorless motor
Dimension: 40x30x16mm (w/o cooling fan)
Net Weight: 31g (without wires and capacitor module)

5. MMax Pico Programming Parameters

Parameters	Values
Run Mode	Practice/Race/Blinky
SBEC Voltage	5.0V to 7.4V
Forward Power	50% to 100%
Reverse Power	25% to 100%
Sensor Mode	Full Sensored/ Smart Sense
Motor Rotation	Normal/ Reverse
Battery Cut Off	Disable/ 3.0V to 7.4V
Motor Temperature Cut	Disable/ 160 degrees F (71 degrees C) to 230 degrees (110 degrees C)
ESC Temperature Cut	Disable/ 160 degrees F (71 degrees C) to 230 degrees (110 degrees C)
Quick Boot	On/Off
Brake Strength	0% (disable) to 100%
Brake PWM	500Hz/1KHz/1.5KHz/2KHz/2.5KHz/3.2KHz/4KHz/5KHz/6.4KHz
Brake Curve	-EXP1 to -EXP5 / Linear / -EXP1 to -EXP5
Drag Brake	0% (disable) to 100%
Initial Brake	0% to 50%
Throttle PWM	1KHz/1.5KHz/2KHz/2.5KHz/3.2KHz/4KHz/5KHz/6.4KHz/8KHz/9.6KHz/12KHz/16KHz/32KHz
Throttle Punch	1% to 100%
Throttle Curve	-EXP1 to -EXP5 / Linear / -EXP1 to -EXP5
Dead Band	Narrow/Middle/Wide

Parameter 1: Run Mode

Options are Practice/Race Blinky

Practice allows all settings to be adjusted on the ESC. Race Blinky locks out reverse power in the profiles.

Parameter 2: SBEC Voltage

Options are from 5.0V to 7.4V in 0.1V Increments.

A higher voltage will make servos react faster at the expense of a shorter life span. However, do not set SBEC Voltage above the servo manufacturer's recommended voltage.

Parameter 3: Forward Power

Options are from 50% to 100% in 1% Increments. This setting allows you to limit the forward power.

Parameter 4: Reverse Power

Options are from 25% to 100% in 1% Increments. This setting allows you to limit the reverse power.

Parameter 5: Sensor Mode

Options are Full Sensored and Smart Sense

The Full Sensored mode will operate the ESC in sensed only mode. It will provide the highest performance and smoothest power at all times. The Smart Sense mode will allow the Esc to operate with either a sensorless or sensed motor. This option can be helpful in the case of sensor wire malfunction or failure.

Parameter 6: Motor Rotation

Options are normal and reverse.

This allows for the changing of motor rotation for some specific chassis that require to run a reversed motor rotation.

Parameter 7: Battery Cut Off

Options are Disable, 2.8V to 7.4V in 0.1V increments.

This parameter monitors the Li-Po pack voltage. If the voltage drops to the setup value, the ESC will reduce the power output to the motor to avoid battery damage.

Parameter 8: Motor Temperature Cut

Options are Disable/ 160 degrees F (71 degrees C) to 230 degrees (110 degrees C).

This parameter displays both Fahrenheit and Celsius (°F and °C) for easier reading. When the motor reaches the setup temperature value, the ESC will reduce the power output to the motor to 30% to avoid overheat damage.

Note: This temperature is read from the sensor unit circuit inside the motor can. There can be discrepancies between the temperature that you capture on the outside of the motor can and what the sensor board is indicating.

Parameter 9: ESC Temperature Cut

Options are Disable/ 160 degrees F (71 degrees C) to 230 degrees (110 degrees C).

This parameter displays both Fahrenheit and Celsius (°F and °C) for easier reading. When the ESC reaches the setup temperature value, the ESC will reduce the power output to the motor to 30% to avoid overheat damage.

Note: This temperature is read from the CPU temperature sensor. It may be different from the temperature that you capture from the ESC heat sink.

Parameter 10 Quick Boot

Options are On and Off.

When Quick Boot function is on, the ESC will boot up without initialization procedure and make the boot up time shorter.

Parameter 11: Brake Strength

Options are 0% (Disabled) to 100%, in 1% Increments.

A lower Brake Strength percentage will have less powerful brakes, while a higher percentage will have stronger brakes.

different from the temperature that you capture from the ESC heat sink.

Parameter 12: Brake PWM

Options are 500Hz/1KHz/1.5KHz/2KHz/2.5KHz/3.2KHz/4KHz/5KHz/6.4KHz
 PWM stands for Pulse Width Modulation and is rated in Hertz, meaning cycles per second. A lower frequency will have a more aggressive braking feel. A higher frequency results in smoother braking, is more precise, and increases the ESC temperature.

Parameter 13: Brake Curve

Options are 100% ~ 10% / Linear / -10% ~ -100%.

A negative % Brake Curve will have a softer brake feel at the beginning of the brakes being engaged and get more aggressive as the brake is fully engaged. A linear Brake Curve will be uniform

throughout the whole brake range. A positive % Brake Curve has strong brakes initially and then becomes softer.

Parameter 14: Initial Brake

Options are 0% to 50% in 1% increments.

This will set the minimum brake force when pushing the throttle trigger from neutral point to the initial brake position. A higher value will provide stronger brake strength when it engages.

Parameter 15: Drag Brake

Options are 0 (disable) to 100% in 1% Increments.

This function will provide a drag force when the throttle is released to the neutral position.

Parameter 16: Throttle PWM

Options are

1KHz/1.6KHz/2KHz/2.5KHz/3.2KHz/4KHz/6.4KHz/8KHz/9.6KHz/12KHz /16KHz/32KHz

PWM stands for Pulse Width Modulation and is rated in Hertz, meaning cycles per second. A lower frequency will have a more aggressive throttle feel and have less motor RPM. A higher frequency results in smoother throttle, is more precise, produces more motor RPM, but will increase ESC temperatures.

Parameter 17: Throttle Punch

Options are 1% to 100% in 1% increments.

A lower Throttle Punch percentage will have a slower throttle response and feel softer initially. A higher Throttle Punch percentage will have a faster throttle response.

Parameter 18: Throttle Curve

Options are 100% ~ 10% / Linear / -10% ~ -100%.

A negative % Throttle Curve will have a softer throttle feel at the beginning of the throttle being engaged and get more aggressive as it is fully engaged. A linear Throttle Curve will be uniform throughout the whole throttle range. A positive % Throttle Curve has strong throttle initially and then becomes softer.

Parameter 19: Dead Band

Options are Off/Narrow/Middle/Wide

This is the amount of "play" when the throttle is engaged. A setting of 'Off' will make the throttle engage more instantaneously, while 'Wide' would require more trigger movement.

6. Factory Profiles

The MMax Pico ESC provides 6 profiles. You can select a corresponding profile for your application. You can also reload factory default settings for each profile via the ProLink or a PC. You can also fine tune all parameters in each profile to meet your needs.

Parameters	Profile 1	Profile 2	Profile 3	Profile 4	Profile 5	Profile 6
	Off Road 2WD Blinky	Off Road 4WD Blinky	TC Blinky	Crawler	Custom 1	Custom 2
Run Mode	Race Blinky	Race Blinky	Race Blinky	Race Blinky	Practice	Practice
SBEC Voltage	6.0V	6.0V	6.0V	6.0V	6.0V	6.0V
Forward Power	100%	100%	100%	100%	100%	100%
Reverse Power	-	-	-	-	50%	50%
Sensor Mode	Full Sensored	Full Sensored	Full Sensored	Full Sensored	Smart Sense	Smart Sense
Motor Rotation	Normal	Normal	Normal	Normal	Normal	Normal
Battery Cut Off	6.4V	6.4V	6.4V	6.4V	6.4V	6.4V
Motor Temperature Cut	220°F/104°C	220°F/104°C	220°F/104°C	220°F/104°C	220°F/104°C	220°F/104°C
ESC Temperature Cut	220°F/104°C	220°F/104°C	220°F/104°C	220°F/104°C	220°F/104°C	220°F/104°C
Brake Strength	100%	100%	100%	100%	100%	100%
Brake PWM	1.6KHz	2.5KHz	1.6KHz	1.6KHz	1.6KHz	1.6KHz
Brake Curve	Linear	Linear	Linear	Linear	Linear	Linear
Drag Brake	5%	3%	5%	100%	0%	0%
Initial Brake	disable	disable	disable	disable	disable	disable
Throttle PWM	2.5KHz	4KHz	2.5KHz	4KHz	4KHz	4KHz
Throttle Punch	100%	100%	100%	75%	75%	75%
Throttle Curve	Linear	Linear	Linear	Linear	Linear	Linear
Dead Band	Middle	Middle	Middle	Middle	Middle	Middle

7. Service & Warranty

Your Maclan MMax Pico ESC is guaranteed to be free from defects in materials and workmanship for a period of 120 days. Your original receipt showing the item and the date and place of purchase is required with your warranty service application. An ESC that is found to have been mishandled, abused or used incorrectly, including use in an application other than that for which the ESC is intended, will not be covered under the warranty. Maclan Racing has no control over the use of the ESC application with other electronic devices such as motors and batteries. Maclan Racing is not liable for any loss or damage, whether direct or indirect, incidental, or consequential, or any situation from the use, misuse or abuse of the product. Your MMax Pico ESC is not a toy. This product is not intended for use by a child under age of 14 without a adult supervision. The MMax Pro ESC generates a lot of power that could result in physical injuries. By setting up, connecting or operating the product, the user accepts all related liabilities.

For service, please visit www.hadrma.com and follow the service instructions for the quickest turnaround time. Or call us at 1-866-206-8558.

For all technical questions, please visit www.maclan-racing.com for the corresponding FAQ, or e-mail your question to service@hobbyauthority-dst.com

Maclan Racing offers a product trade-in program and reserves the right for all warranty applications. Please visit www.maclan-racing.com for details.

WWW.MACLAN-RACING.COM

Made in Taiwan





1. MMax Pro/Pico Physical Diagram

- ❶ Fan power port
- ❷ RX receiver port
- ❸ Power switch port
- ❹ Micro USB host port
- ❺ LED #1
- ❻ LED #2

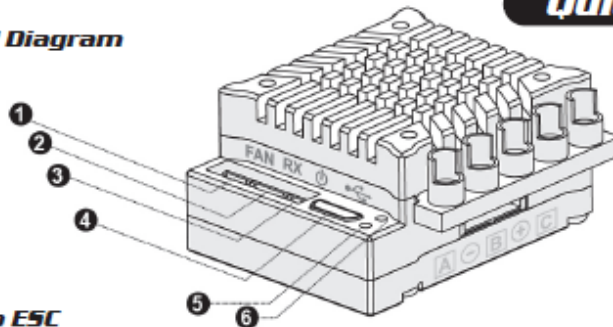

2. Power on MMax Pro/Pico ESC

There are 2 ways to power on and off MMax ESC; with the included slide switch plugged into the ESC, it will be controlled by the switch. If the slide switch is not installed, the ESC power is controlled by the battery connection and the ESC will power on as soon as the battery is plugged in. It will then power off when the battery is unplugged.

3. Radio Calibration

a. Power on your transmitter with the ESC off.

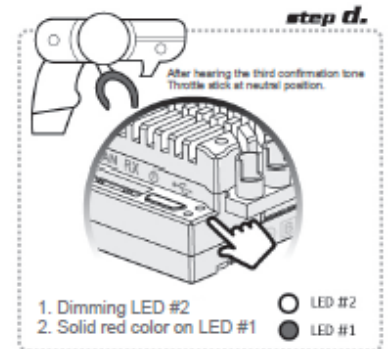
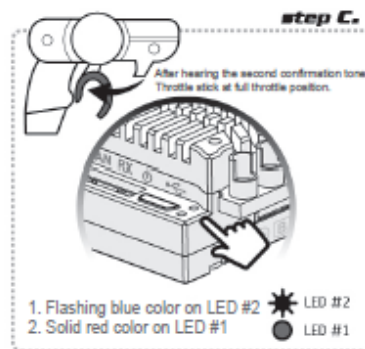
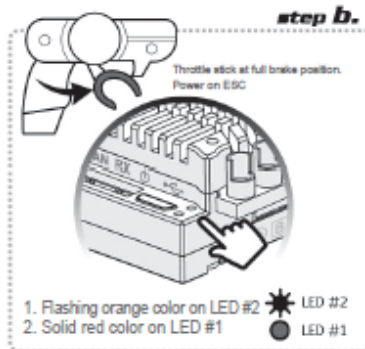

- b.** Hold FULL BRAKE on your transmitter while powering on the ESC. You will get a confirmation tone. You will see a solid RED on LED #1 with flashing ORANGE LED #2. (The flashing ORANGE LED means the ESC is capturing the FULL BRAKE position)
- c.** When the ORANGE LED turns solid, you will get a second confirmation tone. The LED #2 will begin flashing BLUE. Apply FULL THROTTLE now. (The flashing BLUE LED #2 means the ESC is capturing the FULL THROTTLE position)
- d.** When the BLUE LED turns off with a third confirmation tone, release the throttle to neutral position. The ESC is now capturing the neutral position.
- e.** You will get a power-on tone to confirm the calibration process is complete.

****A complete radio calibration video could be found from Maclan Racing web site and its YouTube channel. Visit the web site to view the complete process.**

4. Programming MMax Pro/Pico ESC

There are some options to program your Maclan MMax Pro/ Pico ESC. You can connect the MMax Pro/ Pico ESC to Maclan ProLink (sold separately) via the RX (receiver) port on the ESC, or to the micro USB port to change settings. You can connect MMax Pro/ Pico ESC to a Windows 7/10 PC via its micro USB port to change settings. You will need to download Maclan Panel PC software from Maclan web site. The web site address is www.Maclan-Racing.com. You can also connect MMax Pro/ Pico to an Android based mobile device (Android OS version 5.0 and up) to change settings by Maclan Smart Link app (to be released in autumn of 2017)

5. Firmware Update

- 1. Download the latest firmware from www.maclan-racing.com
- 2. Connect MMax Pro USB to a Windows 7 or Windows 10 PC
- 3. Run the firmware updating software and follow the instruction on the screen

6. LED Indicators

	LED 1	LED 2	Actions
Power on & no receiver signal	Red	Blue	LED 1 & 2 flash every sec simotaneously
Power on & ROAR blinky mode	Red	Blue & Orange	LED 1 (solid) + LED 2 (alternating blue & orange)
Power on & race open mode	Red	Blue	LED 1 (solid red) + LED 2 (solid blue)
Power on & vehicle runs forward	Red	Blue	LED 1 (solid Red) + LED 2 flashes blue rapidly to solid (full throttle)
Power on & vehicle brakes	Red	Orange	LED 1 (solid Red) + LED 2 flashes orange rapidly to solid (full brake)
Low voltage cut off	Red	Blue	LED 1 & 2 flash every sec alternatly with motor beeping
ESC temperature cut off	Red	Orange	LED 1 & 2 flash twice every sec alternatly with motor beeping
Motor temperature cut off	Red	Orange	LED 1 & 2 flash 3 times every sec alternatly with motor beeping