

Name: _____ Date: _____ Event: _____
 City: _____ State: _____ Track: _____

Track Conditions

<input type="checkbox"/> Indoor	<input type="checkbox"/> Tight	<input type="checkbox"/> Asphalt	<input type="checkbox"/> Sealed	<input type="checkbox"/> Low Bite
<input type="checkbox"/> Outdoor	<input type="checkbox"/> Open	<input type="checkbox"/> Concrete	<input type="checkbox"/> Smooth	<input type="checkbox"/> Med Bite
		<input type="checkbox"/> Carpet	<input type="checkbox"/> Rough	<input type="checkbox"/> High Bite

Front Suspension

Toe: _____
 Ride Height: _____
 Camber: _____
 Kick/Anti-Dive: _____
 Caster: _____
 Droop: _____
 Front Pivot: 0° 1° 2°
 Roll Center: _____
 Arm Spacing: _____
 Shock Position: _____
 Steering Rack: _____
 Spindle Ackerman: _____
 Camber Link: _____
 Camber Ball Stud: _____
 Sway Bar: _____

Up Travel: _____
 Arm Length: Short Long
Front Drivetrain
 Front Drive: Spool One-way Diff
 Grease Type: _____
 Pulley: 41 42
 Diff Height: High Low
 Drive Axle: _____
 Hex Width: .165 stk. .195 .225
Shocks
 Oil: _____
 Oil Brand: _____
 Piston: _____
 Spring: _____
 Bladder: _____
 Above Bladder: _____

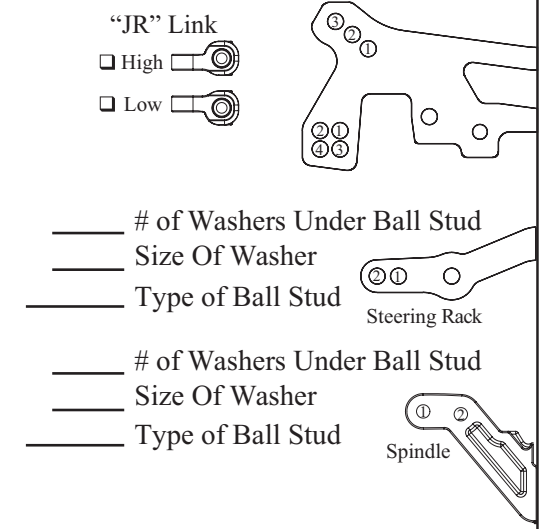

Rear Suspension

Toe: _____
 Ride Height: _____
 Droop: _____
 Camber: _____
 Anti/Pro Squat: _____
 Hub: STD. Offset 0° 1/2° 1° 2°
 Rear Pivot: 0° 1° 2°
 Roll Center: _____
 Arm Spacing: _____
 Shock Position: _____
 Camber Link: _____
 Camber Link Ball Stud: _____
 Sway Bar: _____

Up Travel: _____
 Arm Length: Short Long
Rear Drivetrain
 Diff Height: High Low
 Drive Axle: _____
 Hex Width: .165 stk. .195 .225
Shocks
 Oil: _____
 Oil Brand: _____
 Piston: _____
 Spring: _____
 Bladder: _____
 Above Bladder: _____

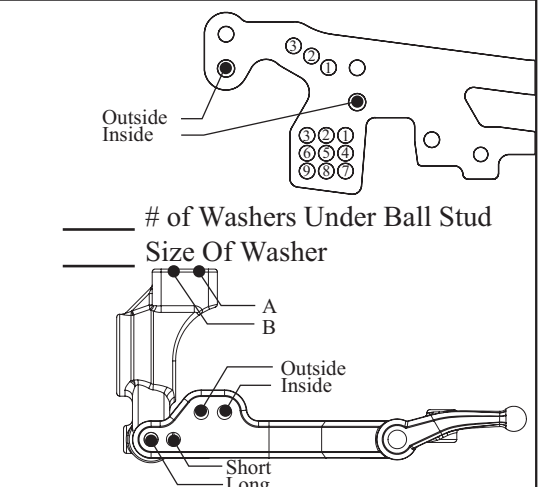

Body _____
 Wing _____
 FR Body Hole _____
 RR Body Hole _____
 5th Body Hole _____
 Body Height _____

Inside
 Outside

Motor _____
 Turns _____
 Brushes _____
 Springs _____
 Timing _____

Spur Gear _____
 Pinion Gear _____
 Ratio _____
 Roll Out _____
 Fans _____

Servo _____
 ESC _____
 Receiver _____
 Battery _____
 Transponder Location _____

Tires:	Brand/Compound	Size (mm)	Insert	Wheel	Tire Warmers
Front:	_____	_____	_____	_____	<input type="checkbox"/> YES Temp °F or C
Rear:	_____	_____	_____	_____	<input type="checkbox"/> NO

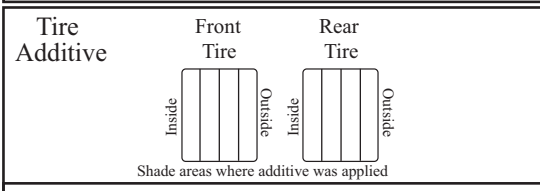

NOTES:

Weight Location and Size