

Name: Shin Adachi Date: 30/Aug/2011 Truck / City: WANGAN Circuit Event: _____

Front Suspension

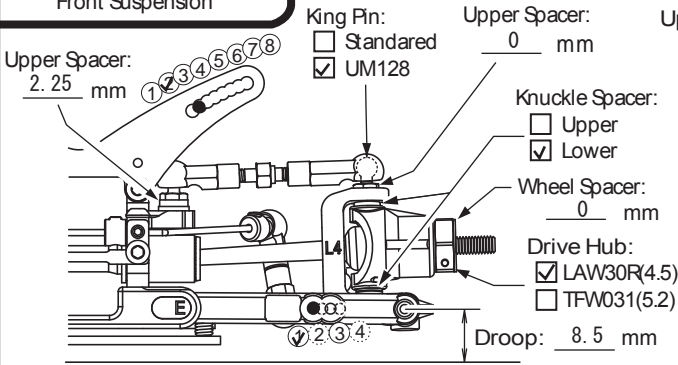

Upper Rod Position:

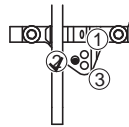

Diff. Position:



Sus. Arm Spacer:
Front 3 mm
Rear 0 mm

Knuckle Spacer:
1 mm

Ride Height:
5.0 mm

Sway Bar: 1.4 mm

Toe Angle: 0.5 °

Sus. Holder Bush:

Front A In Out B 0.3 mm

Rear A In Out B 0.3 mm

Sus. Holder Spacer:

0 mm

Notes:

- Spool
 Oneway
 Diff.

Rear Suspension

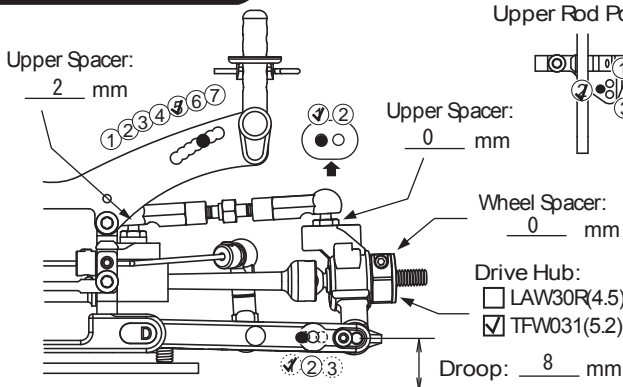

Upper Rod Position:

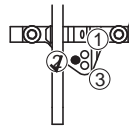

Sus. Arm Spacer:
Front 2.25 mm
Rear 0.5 mm

Diff. Position:

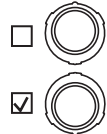

Ride Height:
5.2 mm

Sway Bar: 1.2

Hub Carrier Spacer:

Front 1 mm
Rear 1 mm

Sus. Holder Bush:

Front A IN / OUT C 0.3 mm

Rear A IN / OUT E 0.3 mm

Sus. Holder Spacer:

4 mm

Camber Angle: 2 °

Shock

	Front	Rear
Shock Oil:	# 42.5 (LOS!)	# 42.5 (LOS!)
Shock Spring:	White	White
Diaphragm:	Std	Std
Pressure Form:	None	None
Shock Length:	63.0 mm	63.5 mm

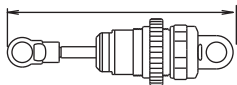

Steering Wiper

Steering Spacer:
0.5 mm

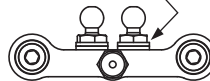

Chassis

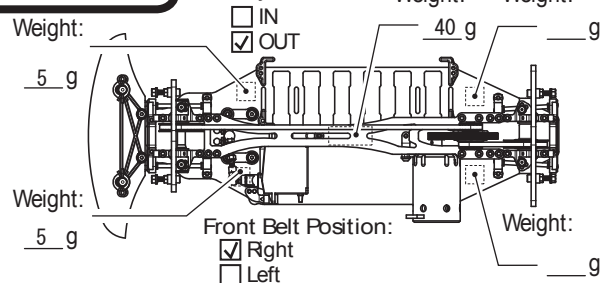

Tire

		Comments
Tire	<u>Rush</u>	<u>Controlled tire</u>
Inserts	<u>Much More</u>	-----
Wheel	<u>Much More</u>	-----
Traction Compound	1st: <u>Mighty</u> 2nd: _____	-----

Others

Motor	<u>ORION VST PRO 5.0T</u>	2nd Gear Ratio: <u>1.83</u>
Pinion/Spur	<u>27 / 115</u>	Gear Ratio <u>7.79</u>
Battery	<u>ORION Lipo 5000 90C</u>	ESC <u>ORION R10 Pro</u>
Body	<u>LTC-R Light Weight</u>	Wing <u>Std</u>

Track Condition

- Smooth Asphalt
 Bumpy Concrete
 Low Truction Carpet
 Med. Truction Indoor
 High Truction Outdoor

Comment:

Use long arms (TF005H) front and rear Gear diff oil : DOT 1