

Name  
坂本 大輔

Date  
2007. 11. 25

Truck / City  
NRCスタジアム

Event  
第1回とりおんカップ

### Front Suspension

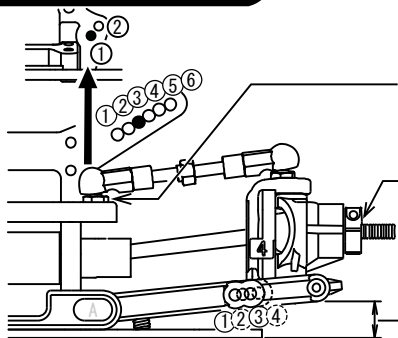

Upper Spacer  
2.5 mm

Wheel Spacer  
0 mm

Droop 7 mm

Diff. Position Front Diff.

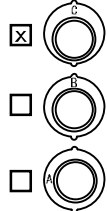

Spool  
 Oneway  
 Diff.

Ride Height  
4.2 mm

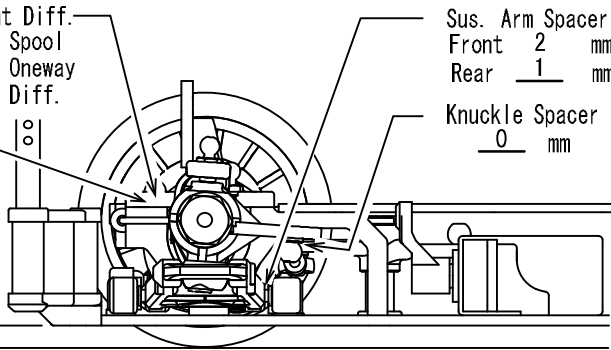

Sus. Arm Spacer  
Front 2 mm  
Rear 1 mm

Knuckle Spacer  
0 mm

Sus. Holder Bush

Front IN / OUT A

Rear IN / OUT A

Sus. Holder Spacer

Front

Rear Front 0 Rear 0

Sway bar 1.3mm

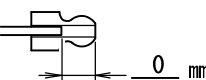

Camber Angle 1.5°

Toe Angle 0 °

Sus. Arm  TF005, TF133  
 TF005H, TF133H

### Rear Suspension

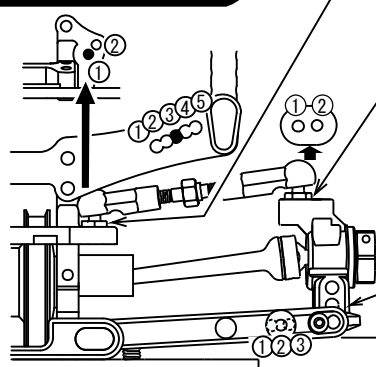

Upper Spacer  
2.0 mm

Upper Spacer  
0 mm

Wheel Spacer  
0 mm

Hub Carrier Height

Up  
 Middle  
 Down

Droop 6 mm

Diff. Position



Hub Carrier  
 0mm offset (SP107H)  
 1.2mm offset (TF009)  
 Aliminum (TFW002)

Hub Carrier Spacer  
Front 1 mm  
Rear 1 mm

Sus. Arm Spacer  
Front 1 mm  
Rear 2 mm

Ride Height  
4.4 mm

Sway bar 1.1mm

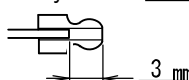

Camber Angle 1.0 °

Sus. Arm  TF005  
 TF005H  
 TF133 (Standard)  
 TF133H

### Shock

	Front	Rear
Shock Piston	<u>2 - C</u>	<u>2 - C</u>
Shock Oil	<u># 350</u>	<u># 300</u>
Shock Spring	<u>ブルー</u>	<u>レッド</u>
Diaphragm	<u>std</u>	<u>std</u>
Pressure Form	<u>Form</u>	<u>Form</u>
Shock Length	<u>61 mm</u>	<u>62 mm</u>

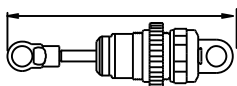

### Steering Wiper

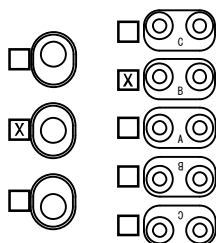

### Chassis

TF126 (Standard)  4cell  
 TFW106  5cell  
 TF103  6cell

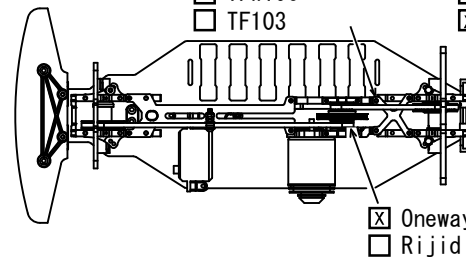

Oneway  
 Rijid

### Tire

Tire	Comments
<u>SOREX 24R</u>	-----
Inserts <u>ゼソンアクア</u>	-----
Wheel <u>ヨコモプレジション</u>	-----
Traction Compound <u>1st:マイティークリッパーV2 2nd:</u>	-----

### Others

Motor KATANA23 3TLF 2nd Gear Ratio : 1.83  
Pinion/Spur 97 / 34 Gear Ratio \_\_\_\_\_  
Battery とりおんForcellMax4300 ESC GM  
Body アレックス LX250 Wing プロトフォーム

### Truck Condition

Smooth  Asphalt  
 Bumpy  Concrete  
 Low Traction  Carpet  
 Med. Traction  Indoor  
 High Traction  Outdoor

Comment : \_\_\_\_\_