

Name

SHINOSUKE ADACHI

Date

2006/11/21

Truck / City

Event

TO SW 2006

Front Suspension

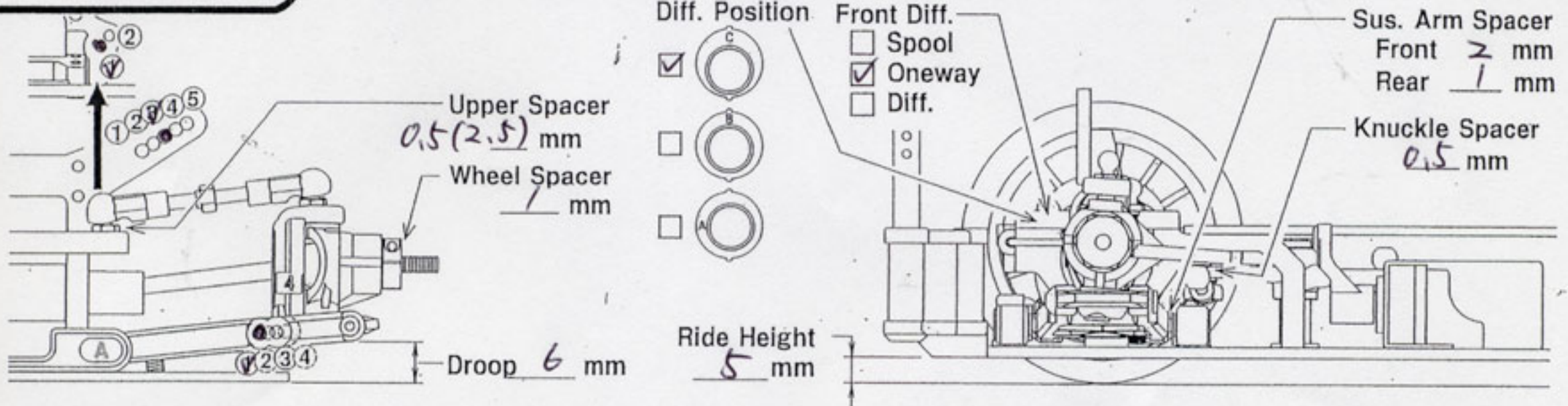

Sus. Holder Bush

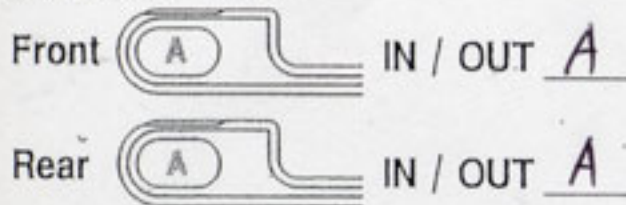

Sus. Holder Spacer

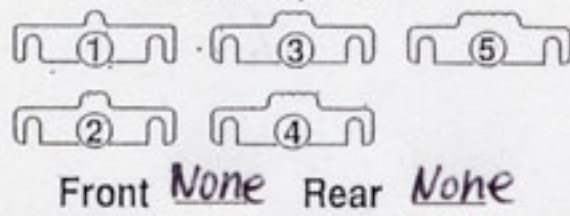

Sway bar None

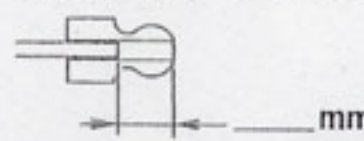

Toe Angle -0.5 °

Camber Angle 1.5 °

Rear Suspension

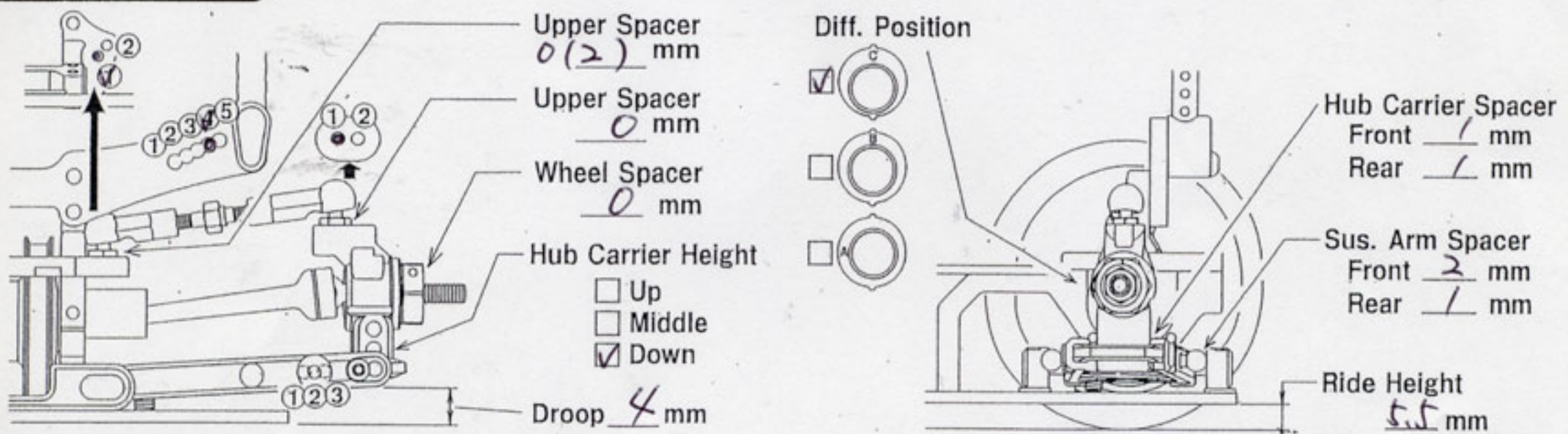

Sus. Holder Bush

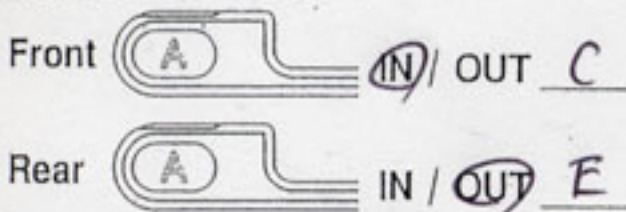

Sus. Holder Spacer

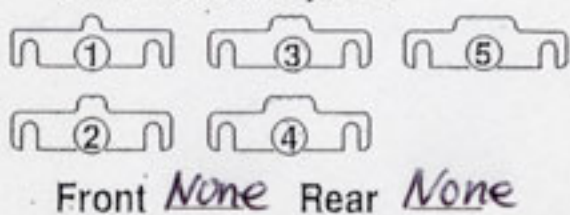

Sway bar None

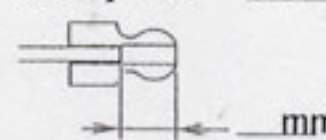

Hub Carrier

- 0mm offset (SP107H)
 1.2mm offset (TF009)

Camber Angle 1.5 °

Shock

	Front	Rear
Shock Piston	<u>1.4-2</u>	<u>1.4-2</u>
Shock Oil	<u># 450</u>	<u># 450</u>
Shock Spring	<u>Yellow</u>	<u>Yellow</u>
Diaphragm	<u>std</u>	<u>std</u>
Pressure Form	<u>None</u>	<u>None</u>
Shock Length	<u>61 mm</u>	<u>62 mm</u>

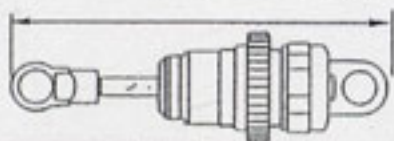

Steering Wiper

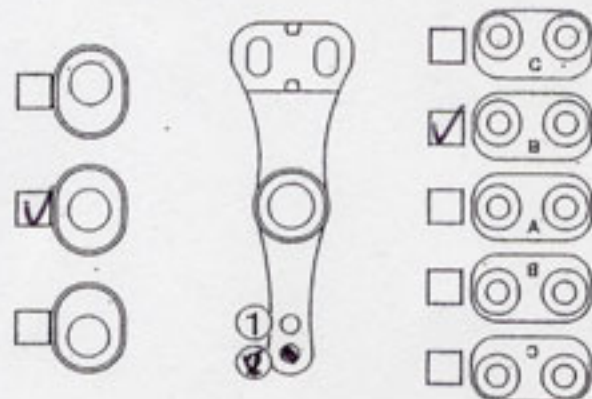

Weight Placement

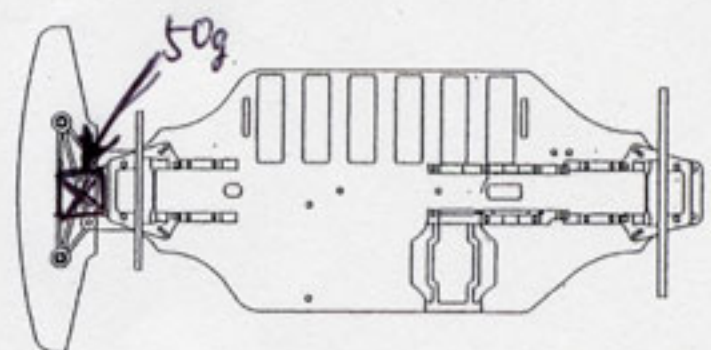

Tire

Tire	Comments
<u>CS 27</u>	<u>Hand out</u>
<u>JB</u>	<u>Hand out</u>
<u>JB</u>	<u>Hand out</u>
Traction Compound 1st: <u>CS High</u> 2nd: _____	

Others

Motor check point 7x1 2nd Gear Ratio : 1.83
 Pinion/Spur 1 Gear Ratio _____
 Battery SBC IB4200WCESC
 Body MAZDA 6 Wing PF High Down face

Truck Condition

- Smooth Asphalt
 Bumpy Concrete
 Low Truction Carpet
 Med. Truction Indoor
 High Truction Outdoor

Comment :