

Name _____

Date _____

Truck / City _____

Event _____

Front Suspension

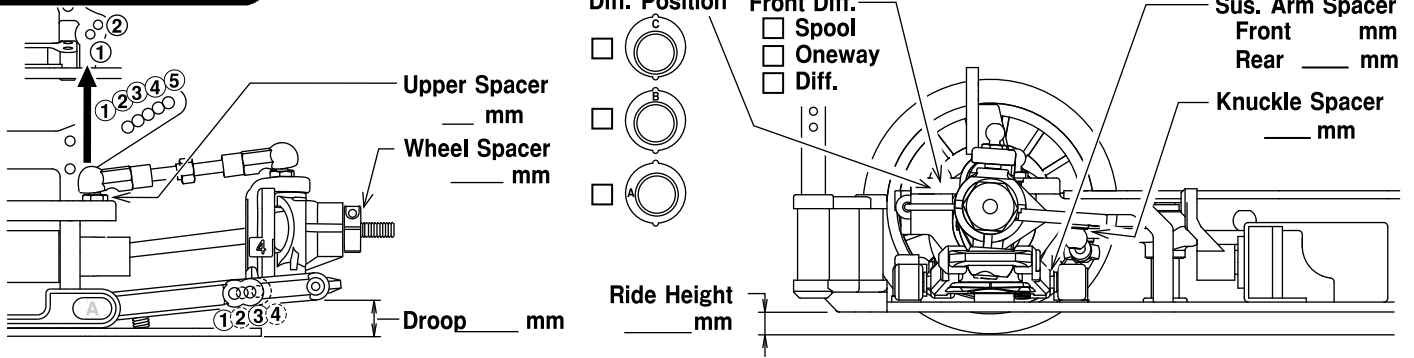

Sus. Holder Bush

Front IN / OUT _____

Rear IN / OUT _____

Sus. Holder Spacer

Front

Rear

Front _____ Rear _____

Sway bar

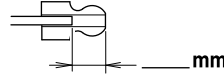

Toe Angle

_____ °

Camber Angle

_____ °

Rear Suspension

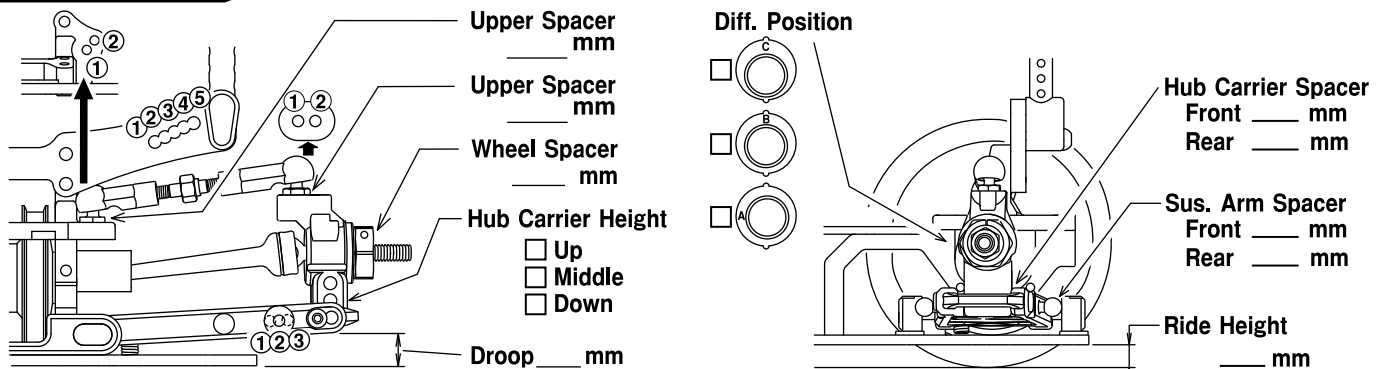

Sus. Holder Bush

Front IN / OUT _____

Rear IN / OUT _____

Sus. Holder Spacer

Front

Rear

Front _____ Rear _____

Sway bar

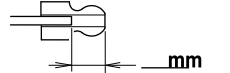

Hub Carrier

- 0mm offset (SP107H)
- 1.2mm offset (TF009)

Camber Angle

_____ °

Shock

Front

Rear

Shock Piston _____
 Shock Oil # _____ # _____
 Shock Spring _____
 Diaphragm _____
 Pressure Form _____
 Shock Length _____ mm _____ mm

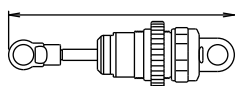

Steering Wiper

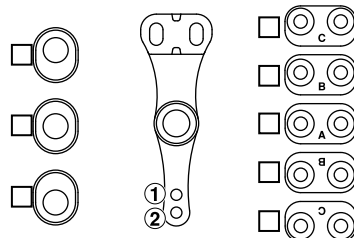

Weight Placement

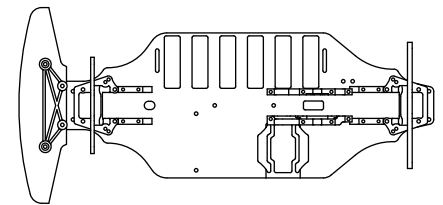

Tire

Tire _____
 Inserts _____
 Wheel _____
 Traction Compound 1st: _____ 2nd: _____

Comments

Others

Motor _____ 2nd Gear Ratio : 1.83
 Pinion/Spur _____ / _____ Gear Ratio _____
 Battery _____ ESC _____
 Body _____ Wing _____

Truck Condition

- Smooth
- Bumpy
- Low Truaction
- Med. Truaction
- Higt Truaction
- Asphalt
- Concrete
- Carpet
- Indoor
- Outdoor

Comment :

