

Name 氏名 Name Nom	Date 日付 Datum Date	Event イベント Veranstaltung Événement	Track サーキット Strecke Piste	Track Condition 路面状況 Streckenzustand Conditions de piste	Temperature 温度 Temperatur Température	Air °	Track °
----------------------------------	------------------------------------	--	---	--	---	-------	---------

Front
フロント
Vorne
Avant

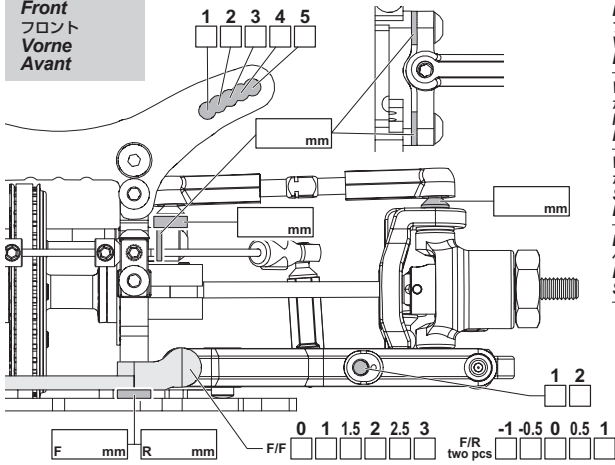

Front Diff フロントデフ Vorderes Differential Diff. avant	Diff Spool One-way	Ride Height 車高 Bodenfreiheit Garde au sol	mm
Wheel Hubs ホイールハブ Radmitnehmer Moyeu	4.5 mm (114535) 5 mm (114536) 6 mm (72036)	Camber Angle キャンバー角 Sturz Angle de carrossage	°
Wheel Spacer ホイールスペーサー Scheibe Espaceur	mm	Caster Angle キャスター角 Nachlauf Angle de chasse	°
Bearing Holder ベアリングホルダー Bearing Holder Support de palier	05 UP 0 05 DOWN	Toe Angle トー角 Vorspur Angle de pincement	°
		Drop ドループ Ausfederweg Course des amortisseurs	mm
		Sway Bar スタビライザー Stabilisator Barre antirollis	1.2 1.3 1.4 mm

Shocks ショック Dämpfer Amortisseurs	Oil wt. オイル番号 Ölviskosität Grade huile
Piston ピストン Kolbenplatte Piston	mm 1 2 3 Holes
Bladder ブラダー Daempfermembran Coupelle	
Spring スプリング Federn Ressorts	
Notes メモ Notizen Notes	

Rear
リア
Hinten
Arrière

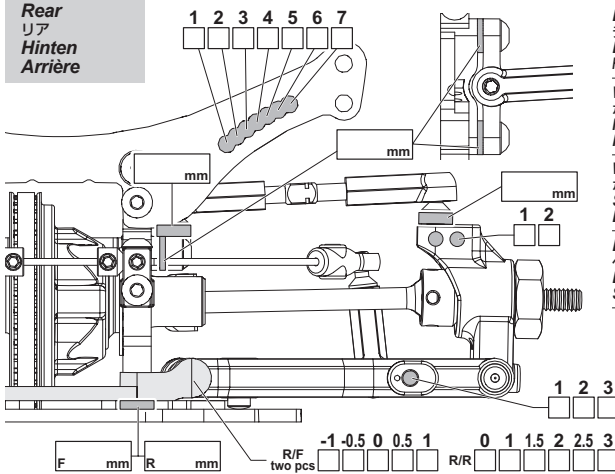

Diff Oils デフオイル Differentialöle Huile silicone p. différentiels	g	Ride Height 車高 Bodenfreiheit Garde au sol	mm
Wheel Hubs ホイールハブ Radmitnehmer Moyeu	4.5 mm (114535) 5 mm (114536) 6 mm (72036)	Camber Angle キャンバー角 Sturz Angle de carrossage	°
Wheel Spacer ホイールスペーサー Scheibe Espaceur	mm	Drop ドループ Ausfederweg Course des amortisseurs	mm
Bearing Holder ベアリングホルダー Bearing Holder Support de palier	25 UP 0 25 DOWN	Sway Bar スタビライザー Stabilisator Barre antirollis	1.1 1.2 1.3 mm

Shocks ショック Dämpfer Amortisseurs	Oil wt. オイル番号 Ölviskosität Grade huile
Piston ピストン Kolbenplatte Piston	mm 1 2 3 Holes
Bladder ブラダー Daempfermembran Coupelle	
Spring スプリング Federn Ressorts	
Notes メモ Notizen Notes	

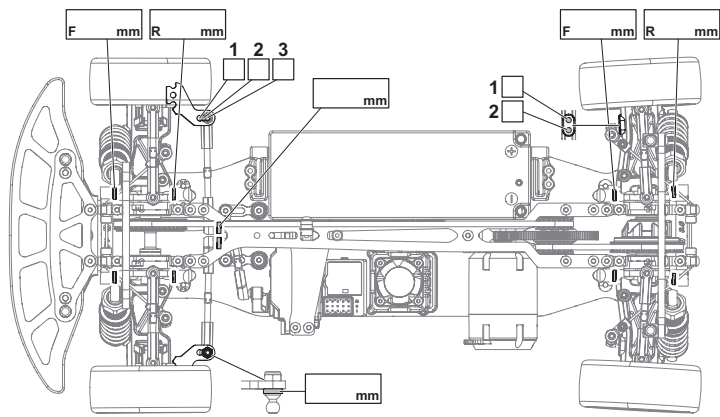

Motor モーター Motor Moteur	
Spur gear スパーギア Hauptzahnrad Couronne	
Pinion gear ピニオンギア Ritzel Pignon	
Battery バッテリー Akku Batterie	
Body ボディ Karosserie Carrosserie	
Wing Type ウイング Type d'ailleron Flügel	

Tires タイヤ Reifen Pneus	Front フロント Vorne Avant	Rear リア Hinten Arrière
Brand 使用タイヤ Hersteller Marque		
Compound コンパウンド Mischung Gomme		
Insert インサート Einlagen Insert		
Wheel ホイール Felge Jante		
Tire Treatment グリップ剤 Reifenbehandlung Traitement des pneus		



Notes
メモ
Notizen
Notes