

Name	Date	Event	Track	Track Condition	Temperature	Air
				Asphalt (Indoor/Outdoor) Carpet		
				Low Medium High		Track
				Bumpy Smooth		

Front

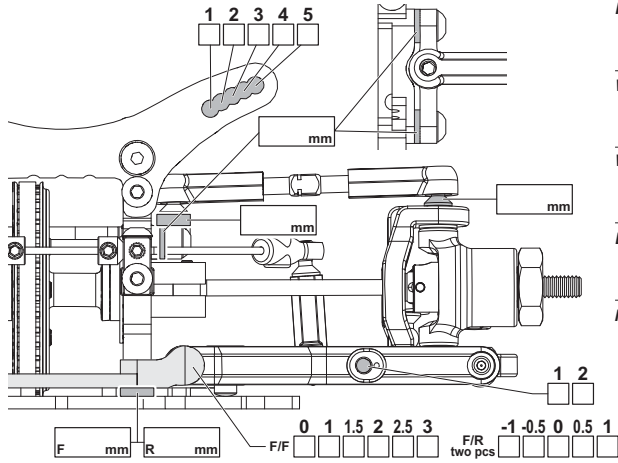

Front Diff Diff Spool One-way

Wheels Hubs 4.5mm (114535) 5.0mm (114536) 6.0mm (72036)

Wheel Spacer _____ mm

Bearing Holder 05 Up 0 05 Down

Notes _____

Ride Height _____ mm

Camber _____ °

Caster _____ °

Toe _____ °

Droop _____ mm

Sway Bar 1.2mm 1.3mm 1.4mm

Shocks

Oil _____

Piston _____

Hole Diameter _____ mm

Nbr of holes: 1 2 3

Bladder _____

Spring _____

Notes _____

Rear

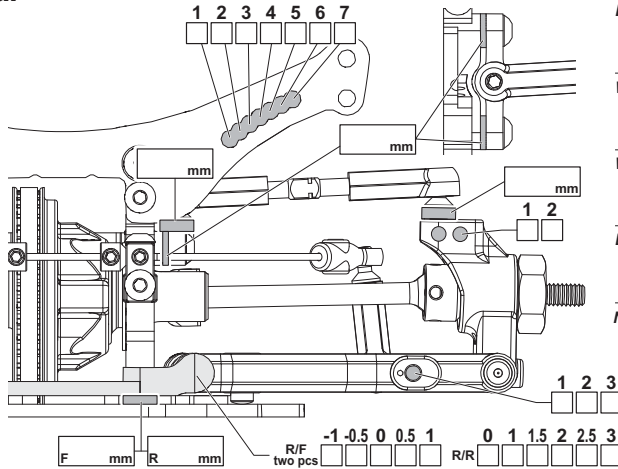

Diff Oil _____

Wheel Hubs 4.5mm (114535) 5.0mm (114536) 6.0mm (72036)

Wheel Spacer _____ mm

Bearing Holder 25 Up 0 25 Down

Notes _____

Ride Height _____ g

Camber _____ °

Droop _____ mm

Sway Bar 1.2mm 1.3mm 1.4mm

Shocks

Oil _____

Piston _____

Hole Diameter _____ mm

Nbr of holes: 1 2 3

Bladder _____

Spring _____

Notes _____

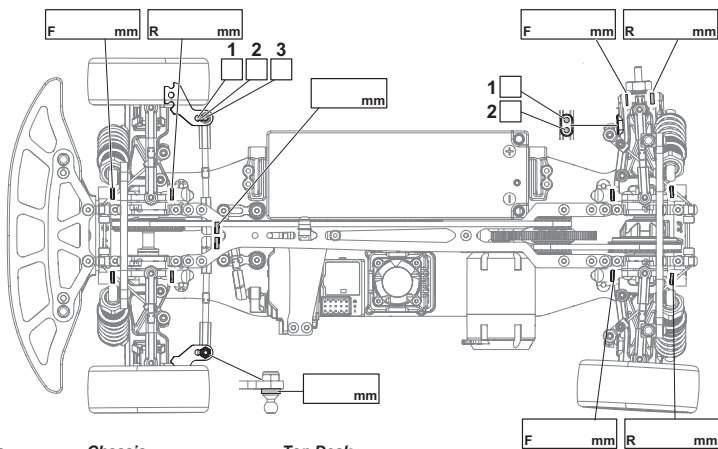

Motor _____

Spur _____ **Pitch** _____

Pinion _____ **Pitch** _____

Battery _____

ESC _____

ESC Setting _____

Body _____

Wing _____

Notes Chassis _____ Top Desk _____

Tires	Front	Rear
Brand	_____	_____
Compound	_____	_____
Insert	_____	_____
Wheel	_____	_____
Additive	_____	_____
Notes	_____	_____

FL FR RL RR