



Setup Sheet



Name **Ty Tessmann**

Date **07/31/2011**

Event **2011 ROAR Paved Nationals**

Temp **Air** Track

Track **Jacson R/C**

Track Condition **Outdoor** Tight **Open** Smooth **Rough** Wet **Dusty** Low Bite **Med Bite** High Bite **Other**

Front

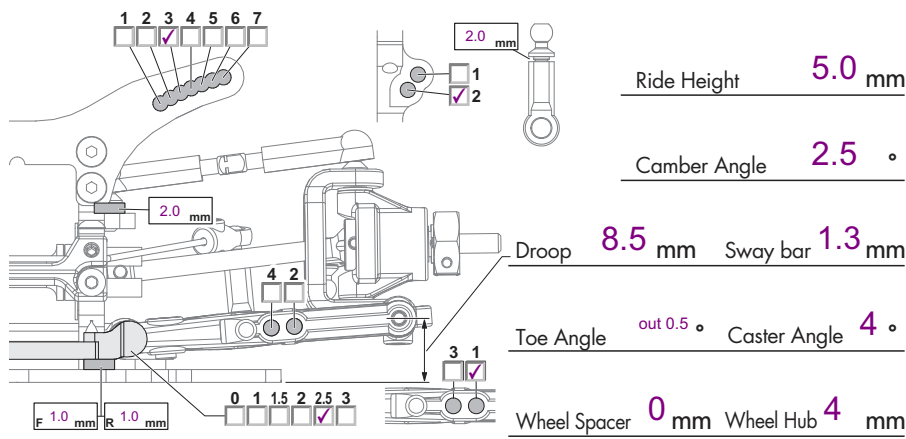

Shocks

	Front	Rear
Piston	1.2mm 3hole	1.2mm 3hole
Oil wt.	40	37.5
Bladder	STD	STD
Spring	6543 silver	6542 blue
Shock Length	62.50 mm	62.50 mm

Rear

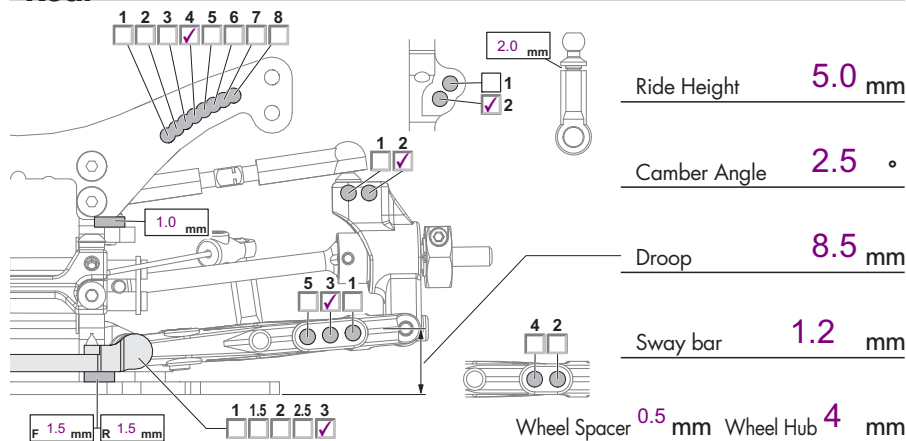

Tires

	Front	Rear
Brand	Solaris Spec	Solaris Spec
Compound		
Insert		
Wheel		
Tire Treatment	Red dot + FX2	Red dot + FX2

Chassis

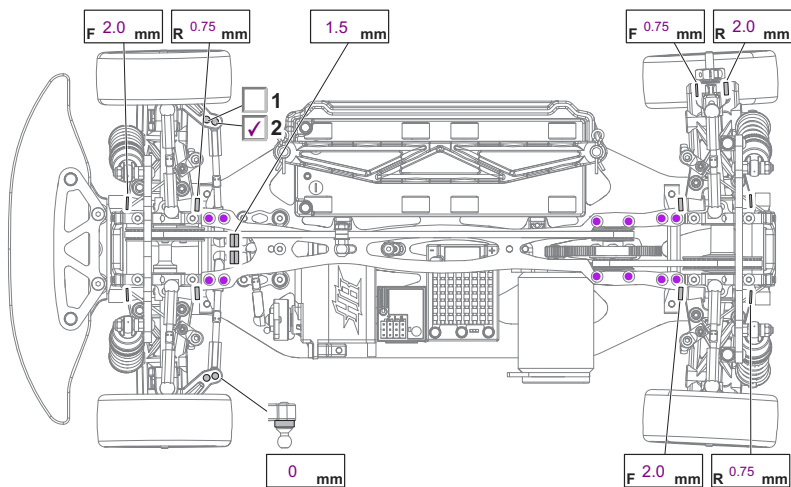

Note

Used #68776 3.5 toe-in block. #67718 no6 short shock end + 1.0mm shim. 0% shock rebound. 44mm DCJ for front. #68760 narrow chassis used.

Diff

	Front	Rear
Type	Gear	Gear
Note	Putty+chain lube	Dot 3

Motor

Motor	Reedy Sonic 4.5T	Spur Gear	115
Battery	Reedy 60C	Pinion Gear	27
Body	PF LTC-R	ESC	SXX TC
Wing	HB	Note	2deg advanced timing



www.hotbodiesonline.com

Hot Bodies USA
70 Icon Street
Foothill Ranch, CA 92610 USA
(949) 753-1099
(888) 349-4474 Customer Service

www.hotbodiesonline.com

HPI Europe
19 William Nadin Way,
Swadlincote, Derbyshire,
DE11 0BB, UK
+44 1283 229400

www.hpiracing.co.jp

HPI Japan
755-1 Aritama Kita-machi,
Higashi-ku, Hamamatsu-shi,
Shizuoka 431-3121 JAPAN
053-432-6161

www.hpiracing.net.cn

HPI China
311# Xiangshi Road,
Kelhan Industrial Park Phase II Standards Plant 6th,
Kunshan, JiangSu, China 215312
(+86) 512-50320780