



# Setup Sheet



Name *Jonathan Porta*

Date *été 2011*

Event *Multiples*

Temp Air Track

Track *Frontenex 2011*

Track Condition

Indoor  Outdoor  Tight  Open  Smooth  Rough  Wet  Dusty  Low Bite  High Bite  Medium Bite  Other

## Front

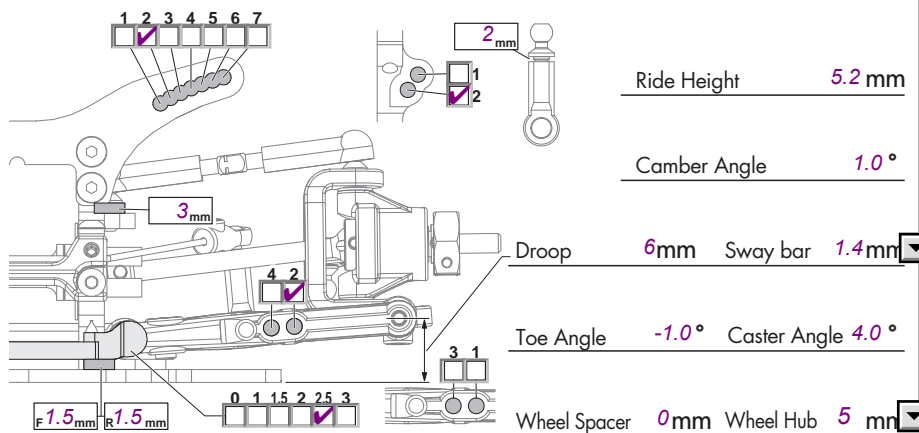

## Shocks

	Front	Rear
Piston	<i>3x1.1mm Tamiya</i>	<i>3x1.1mm Tamiya</i>
Oil wt.	<i>450</i>	<i>450</i>
Bladder	<i>Std</i>	<i>Std</i>
Spring	<i>6543 silver</i> <input checked="" type="checkbox"/>	<i>6543 silver</i> <input checked="" type="checkbox"/>
Shock Length	<i>64.5 mm</i>	<i>64.5 mm</i>

## Rear

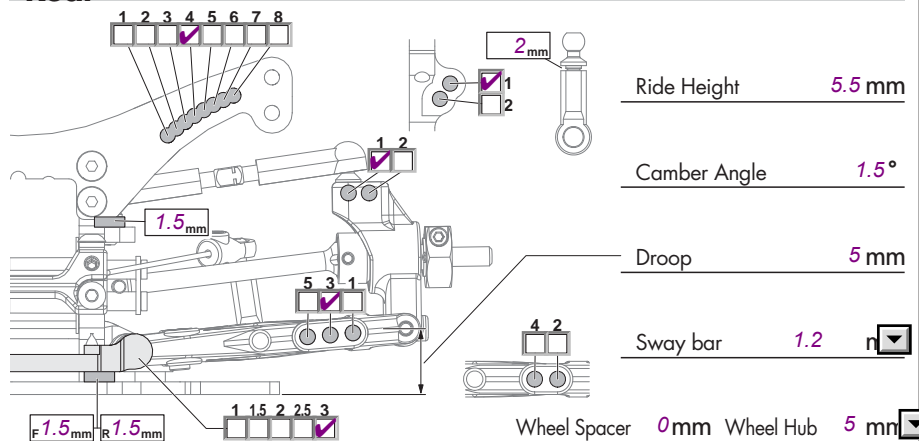

## Tires

	Front	Rear
Brand	<i>Sorex</i>	<i>Sorex</i>
Compound	<i>36R</i>	<i>36R</i>
Insert	<i>GM Green</i>	<i>GM Green</i>
Wheel	<i>GM (SRCCA set)</i>	<i>GM (SRCCA set)</i>
Tire Treatment	<i>none</i>	<i>none</i>

## Chassis

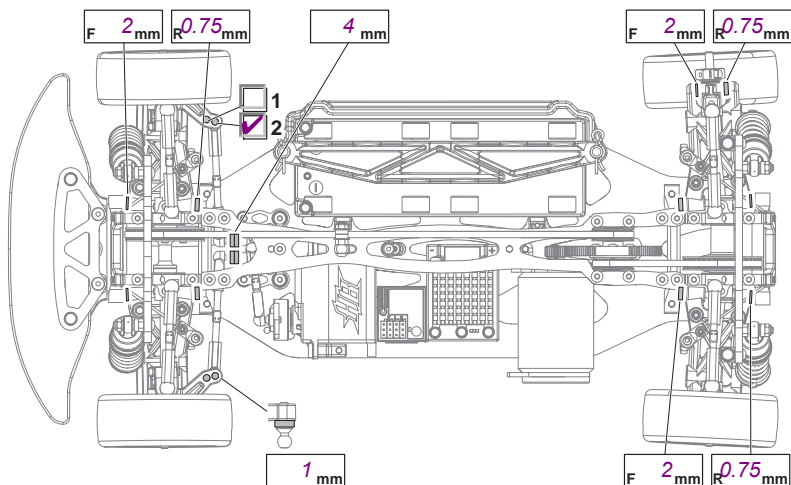

Chassis *Exotek, FF+1°*. Réglages marchant identiquement avec une

Note *Hot-Bodies TC-FD*

## Diff

	Front	Rear
Type	<i>Gear</i>	<i>Gear</i>
Note	<i>500'000</i>	<i>1000</i>

## Motor

Motor	<i>TO 10.5Stock</i>	<i>Spur Gear 114</i>
Battery	<i>CarbonPro 5000</i>	<i>Pinion Gear 44</i>
Body	<i>Protoform P37N</i>	<i>ESC Hobbywing 120A 2.1</i>
Wing	<i>Std</i>	<i>Setup disponible séparément</i>
Note		

Alterations: Arn0 ar PetitRC dot com



www.hotbodiesonline.com  
Hot Bodies USA  
70 Icon Street  
Foothill Ranch, CA 92610 USA  
(949) 753-1099  
(888) 349-4474 Customer Service

www.hotbodiesonline.com  
HPI Europe  
19 William Nadin Way,  
Swadlincote, Derbyshire,  
DE11 0BB, UK  
+44 1283 229400

www.hpiracing.co.jp  
HPI Japan  
755-1 Ariyama Kita-machi,  
Higashi-ku, Hamamatsu-shi,  
Shizuoka 431-3121 JAPAN  
053-432-6161

www.hpiracing.net.cn  
HPI China  
311# Xiangshi Road,  
Keihan Industrial Park Phase II Standards Plant 6th,  
Kunshan, Jiangsu, China 215312  
(+86) 512-50320780