



Setup Sheet



Name _____ Date _____ Event _____ Temp Air _____ Track _____
 Track _____ Track Condition _____ Indoor _____ Tight _____ Smooth _____ Wet _____ Low Bite _____ High Bite _____
 Outdoor _____ Open _____ Rough _____ Dusty _____ Med Bite _____ Other _____

Front

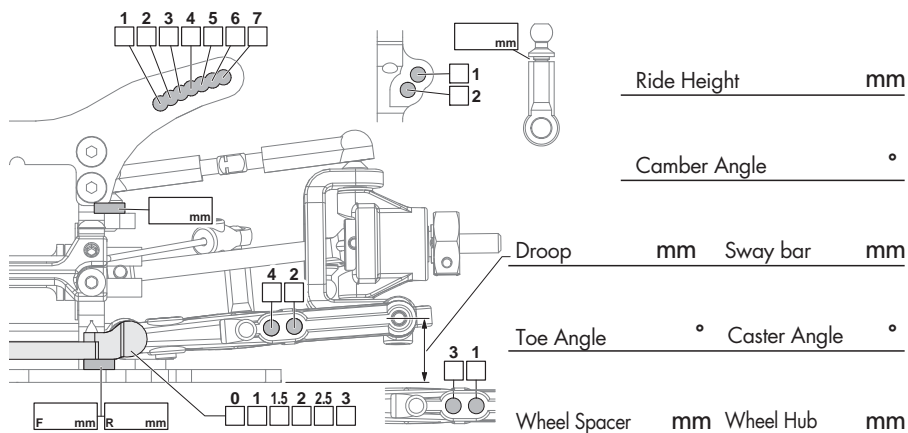

Shocks

Front _____ Rear _____

Piston _____

Oil wt. _____

Bladder _____

Spring _____

Shock Length _____ mm _____ mm

Rear

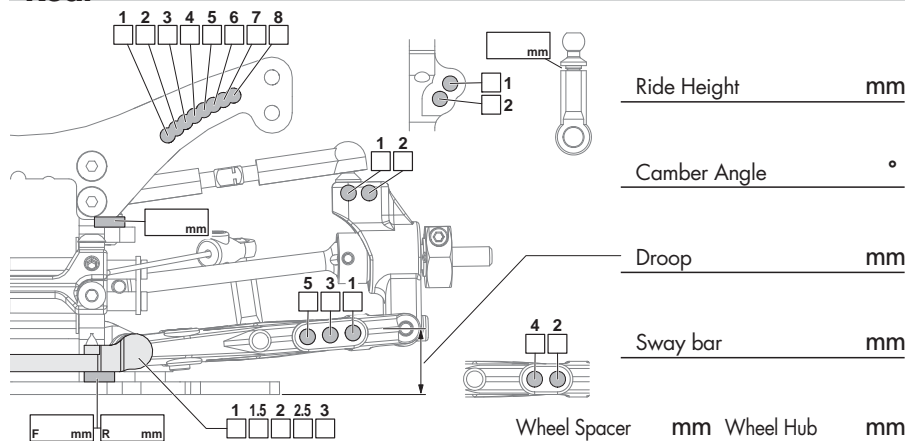

Tires

Front _____ Rear _____

Brand _____

Compound _____

Insert _____

Wheel _____

Tire Treatment _____

Chassis

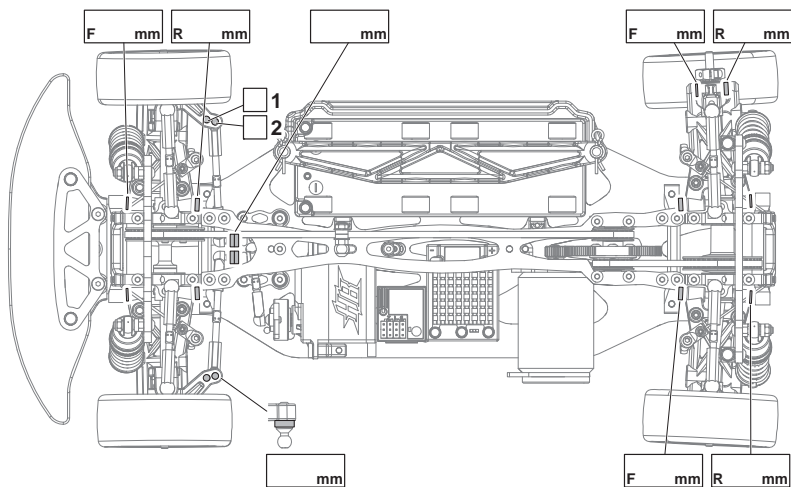

Note _____

Diff

Front _____ Rear _____

Type _____

Note _____

Motor

Motor _____ Spur Gear _____

Battery _____ Pinion Gear _____

Body _____ ESC _____

Wing _____ Note _____



www.hotbodiesonline.com
 Hot Bodies USA
 70 Icon Street
 Foothill Ranch, CA 92610 USA
 (949) 753-1099
 (888) 349-4474 Customer Service

www.hotbodiesonline.com
 HPI Europe
 19 William Nadin Way,
 Swadlincote, Derbyshire,
 DE11 0BB, UK
 +44 1283 229400

www.hpiracing.co.jp
 HPI Japan
 755-1 Aritama Kita-machi,
 Higashi-ku, Hamamatsu-shi,
 Shizuoka 431-3121 JAPAN
 053-432-6161

www.hpiracing.net.cn
 HPI China
 311# Xiangshi Road,
 Keihan Industrial Park Phase II Standards Plant 6th,
 Kunshan, JiangSu, China 215312
 (+86) 512-50320780