

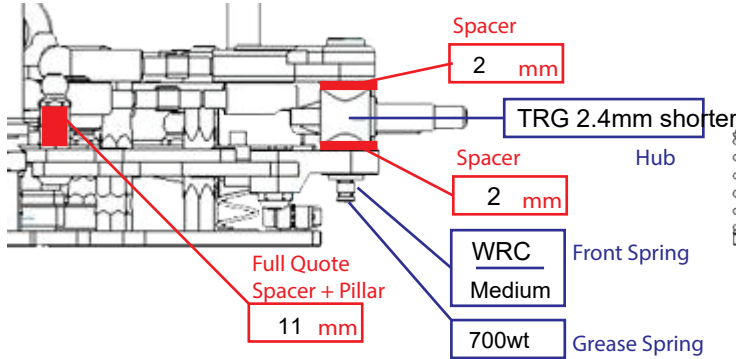

FENIX RACING MISTRAL

Paulo Roberto Martins

Driver : Paulo R Martins Temp : 24C
 Date : October, 18th, 2015 Condition: dry, very windy
 Event : Campeonato Paulista
 Track : www.appa.org.br Surface: Asphalt



Shock Absorber: Team Prime
 Piston: Titanium
 Oil: 400wt
 Spring: Soft
 Length: 61 mm

Roll Damper: F104V2

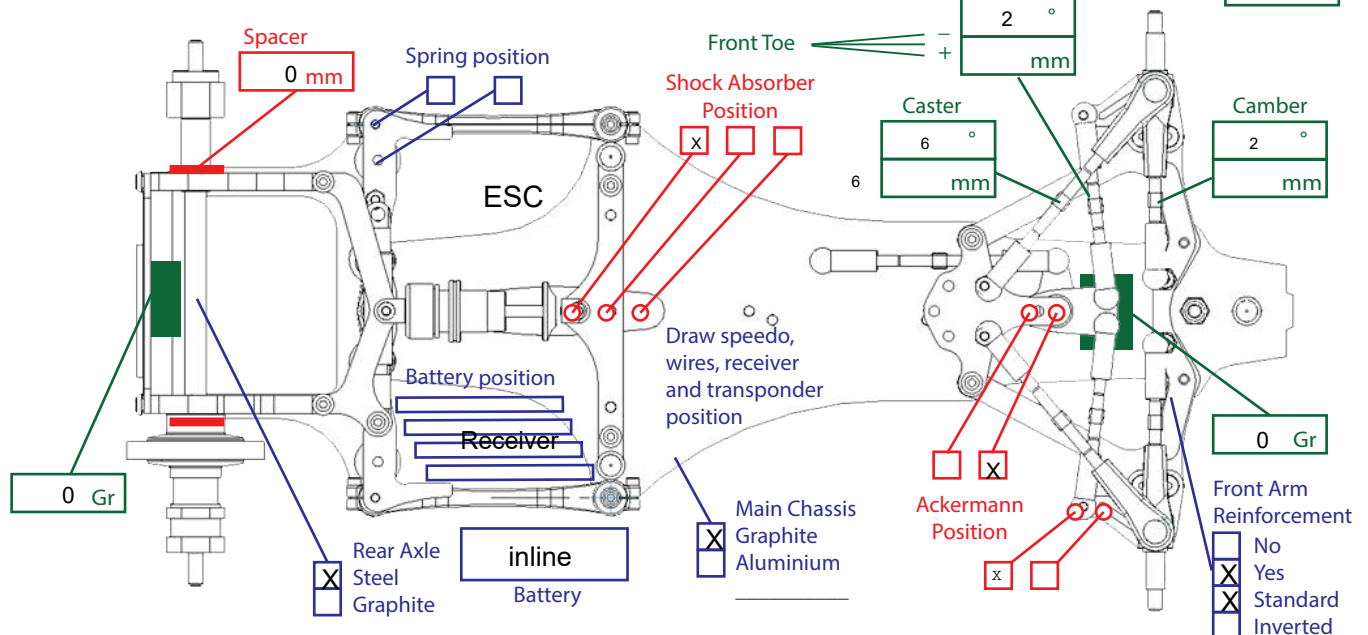
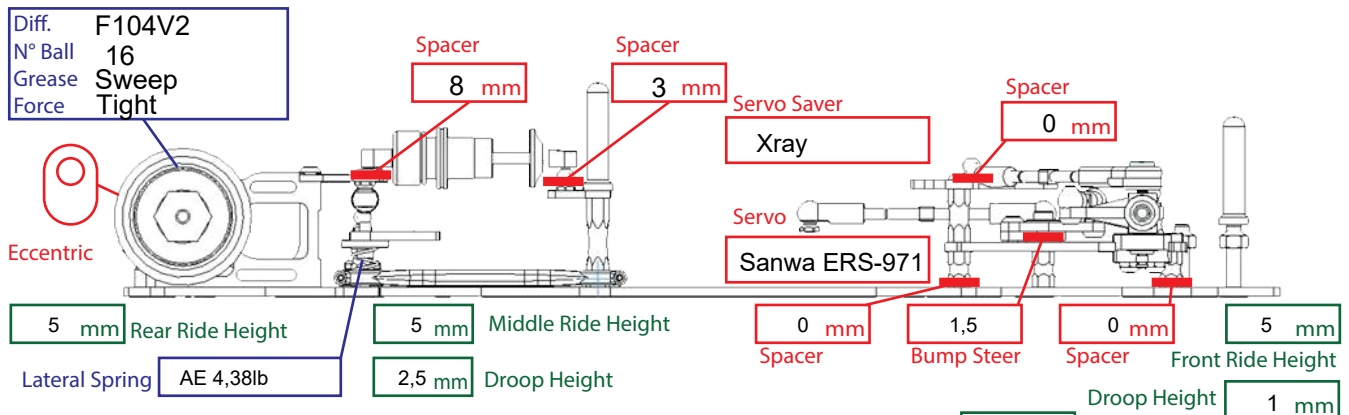
 Oil / Grease diff silicone 30.000



Motor	GM Race 21.5T	Front Tire	GRP	Esc	Team Orion R10.1 Pro
Spur Gear	68T 48P	Wheels	GRP	set up	Blinky mode
Pinion Gear	30T 48P	Inserts	GRP	Radio	Futaba 4PLS
Gear Ratio	2.26	Treatment	wurth + Protek trugrip red	Th EPA	120%
Body	Fenix PhiGamma	Rear Tire	Ride R1	Brake EPA	75%
Front Wing	MonTech	Wheels	Ride	Steering EPA	110%
Rear Wing	TRG	Inserts	Ride	Treatment	Trugrip red
Weight	1079gr	Treatment	wurth brake clean + Protek		