

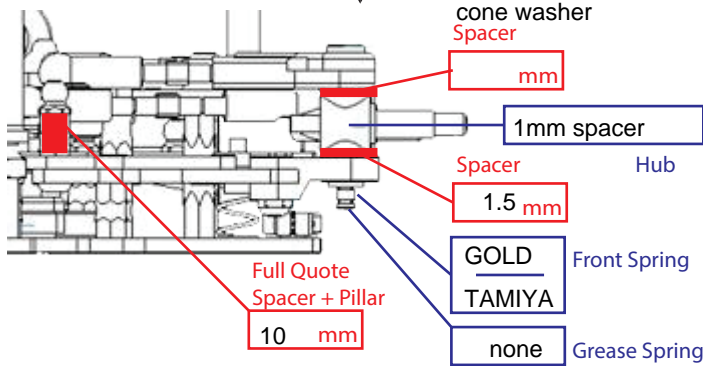

FENIX RACING MISTRAL

Driver : GIORGIO
 Date : 15-18 june 2017
 Event : ETS 5
 Track : HUDY ARENA- SK

Temp : From Rain to Nicely hot
 Condition : Rain change the track often,
 even if they additive it often
 Surface : asphalt



Shock Absorber:

Roll Damper:
 FENIX DUAL

Piston:



Oil: 1500

Spring: SILVER

Oil / Grease

30K - refresh often....

Lenght: _____ mm

Diff. FENIX GEAR
 N° Ball 2.....
 Grease TEFLON
 Force Super free

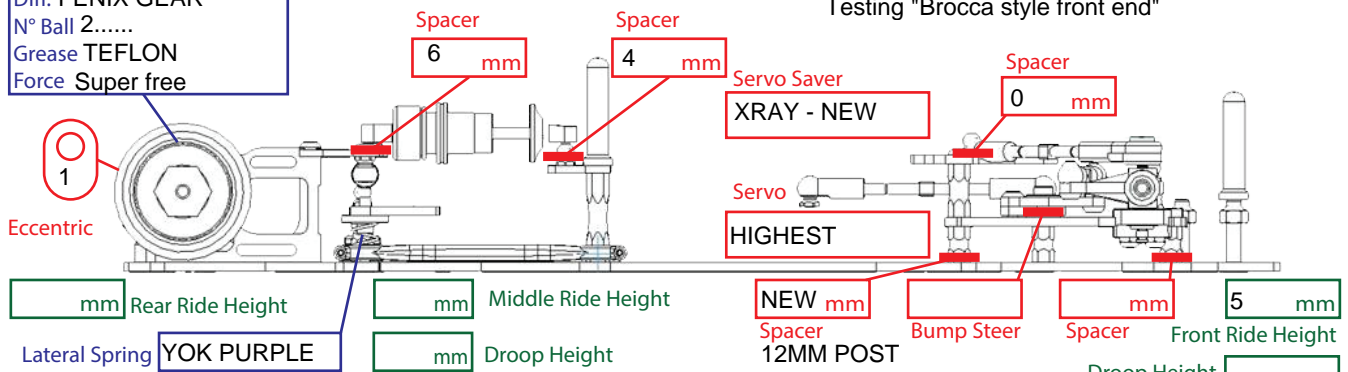

SERVO fully suspended
 Testing "Brocca style front end"

Note: Start with the usual ETS tyre saver setup (battery inline) but I've to switch to traverse. Rain affect the race and we've 2 quali and 2 final Stupid me... I ended in E final, C or D were the target, but I made a mistake in the only real good (new tires) quali.

13 lap - 5.18.078
 23.177

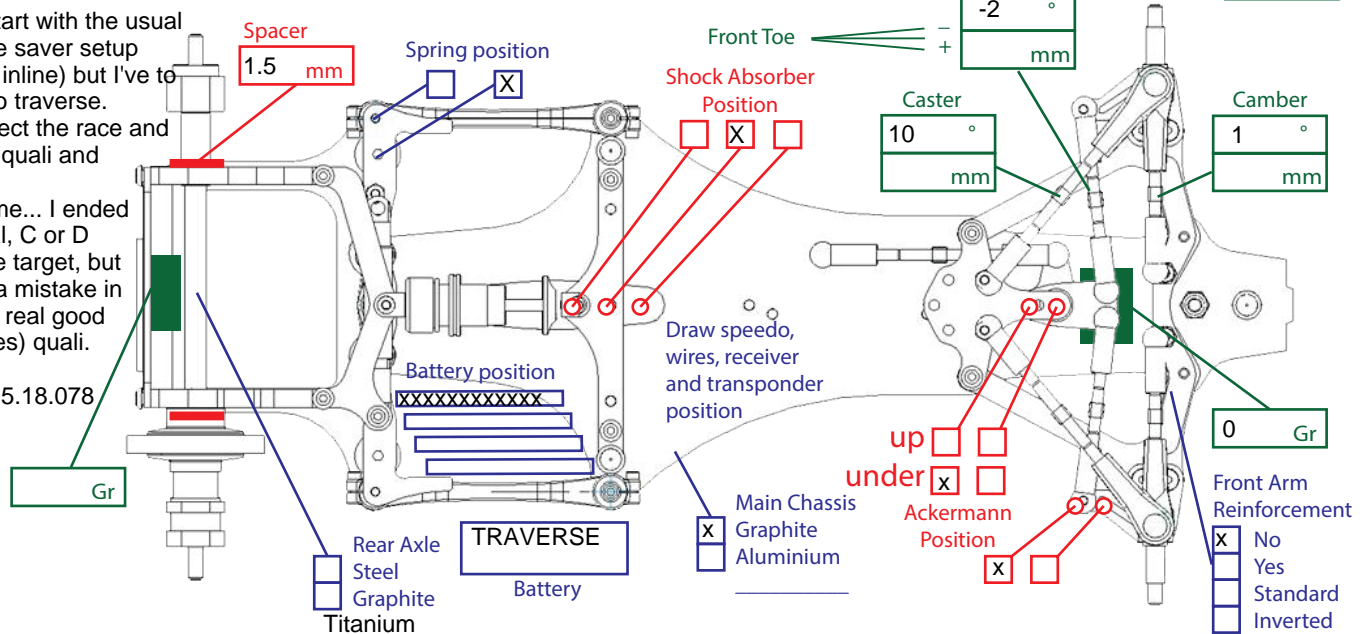

Motor Hobby wing handout 21.5 Spur Gear 84 Pinion Gear 40 Body PHIGAMMA 2 Front Wing Serpent + cutted winglet Rear Wing Montech full height - Weight 1050	Front Tire RIDE GR Wheels Inserts Traitment like rear		Esc ETS - set up Radio Sanwa ZZ Th EPA Full Brake EPA 65% Steering EPA From 95% STEERING CURVE: -43%
	Rear Tire RIDE GR Wheels Inserts Traitment ETS Sauce		